

Thesis Proposal

December 12th 2008

Brian Goodykoontz

Construction Management Option

Advisor: Dr. Anumba

Maryland General Hospital

827 Linden Ave, Baltimore, MD

<http://www.engr.psu.edu/ae/thesis/portfolios/2009/bwg5000/>



TABLE OF CONTENTS

EXECUTIVE SUMMARY	1
ANALYSIS 1: DELIVERY METHOD ANALYSIS.....	2
ANALYSIS 2: ENERGY RECOVERY SYSTEM ANALYSIS	4
ANALYSIS 3: STRUCTURAL REINFORCEMENT REDUCTION ANALYSIS	6
CRITICAL INDUSTRY ISSUE: BIM INTEROPERABILITY	8
BIBLIOGRAPHY	10
Appendix A: Weight Matrix.....	11
Appendix B: Research/Analysis Schedule	12
Appendix C: Breadth Studies.....	13



EXECUTIVE SUMMARY

This proposal is a continuation of the analysis topics brainstormed in technical assignment 3. It outlines the research which will be accomplished in spring semester 2009. As our country moves into an economic recession it will be critical that we get the most out of our investments in materials, labor, and other resources. As such, this proposal focuses on the reduction of waste in the construction process.

Analysis 1: Design Build Delivery Method

For the first analysis research will be completed on the potential impact a design build project delivery method would have on the project. This will be accomplished through review of numerous case studies, the development of a rubric for determining the common characteristics identified with these projects, and evaluation of this rubric for the Maryland General Hospital Project. Quantitatively, this will be evaluated based on the average reduction in cost seen on the case study projects applied as a percentage to the change orders on Central Care Expansion Project.

Analysis 2: Energy System Recovery System Analysis

The next analysis will double as a mechanical breadth topic. This value engineering analysis will evaluate the potential elimination of wasted energy from the mechanical system through the use of a energy recovery system. This will be evaluated based on the initial cost and life cycle cost of the system for the hospital. Additionally, the schedule implication of the change to the system will be evaluated.

Analysis 3: Structural Reinforcement Reduction

The structural reinforcement analysis is a schedule reduction suggestion that will examine potential alteration to the structural system which could reduce the number of areas in which column reinforcement had to be completed. This will be completed through hand calculation of loads on the structure and member sized and the use of structural analysis software which will utilize an interoperable structural model developed in Revit. The primary focus of this analysis is the potential cost and time savings of the decreased number of columns which need to be reinforced to support the new structure above.

Critical Industry Issue Analysis: BIM Interoperability

Finally, research will be completed on the critical industry issue of BIM interoperability which is currently challenging the industry. Specifically this thesis will focus on the process of implementation of facilities management software which is interoperable with models which are created throughout various stages of the project. Additionally, it will focus on industry perceptions, challenges that have been encountered, and the development of a guide to move forward in this field of interoperability.



ANALYSIS 1: DELIVERY METHOD ANALYSIS

Background

Architect, Hord Coplan Macht and Construction Manager, Barton Malow Company are in a design bid build project delivery structure with the University of Maryland Medical System for the Maryland General Hospital Central Care Expansion. Hord Coplan Macht performed the architectural services out of their office and contracted several consultants for the various other aspects of the project such as the mechanical system design. Barton Malow solicited competitive bids for and hired a mechanical contractor to complete all of the HVAC work for the project.

Opportunity for Improvement

There are several opportunities for improvement in the overall delivery of Central Care Expansion. On the project there was a fair amount of waste due to the shop drawing process, serviceability issues, and rework due to design errors and omissions. As with any traditional design bid build project, the shop drawing process results in the complete redrawing of the systems which have already been drawn for the contract documents. Additionally, there are several significant serviceability issues which present themselves on the project. For example, the replacement cooling towers on the existing seventh floor will no longer have crane access once the courtyard is infilled, and the elevator machine room has door openings smaller than the equipment which will go in the room. To replace the cooling towers (which typically only last 20-30 years) they will have to be disassembled and the new assembled on the roof. This will increase the labor cost for installation and potential service disruption. Finally, rework occurred three (3) times on the MRI chilled water piping which had to be relocated on the project due to design errors and omissions. The additional labor and materials to complete this work was non-value added cost to the project.

Potential Solution

The use of a design build contract project delivery method boasts many advantages which could have been extremely useful on this hospital project. According to the article, "Lean and Green: The Role of Design-Build Mechanical Competencies in the Design and Construction of Green Buildings," three common benefits of a design build mechanical contractor as innovative design, integrated design and detailing, and valuable constructability input early on in the process. I will research the implications of a design build on the Maryland General Hospital project.

Research/Analysis Steps

1. Research case studies specifically looking at:
 - a. Project characteristics which make it a good fit with design build
 - b. Time implication due to less rework, the shop drawing process, and
 - c. Cost due to less change orders
 - d. RFI reduction
2. Research the Maryland General Project mechanical contract
 - a. Change orders which resulted in rework
 - i. Increased duration in schedule
 - ii. Cost
 - iii. Cause of the change order
 - b. RFIs count and causes
3. Develop basic rubric for determining good candidates for the design build deliver method.
4. Evaluate if the Central Care Expansion was a good candidate for the design build delivery method utilizing this rubric.

Thesis Proposal

December 12th 2008

Brian Goodykoontz

Construction Management Option

Advisor: Dr. Anumba

Maryland General Hospital

827 Linden Ave, Baltimore, MD

<http://www.engr.psu.edu/ae/thesis/portfolios/2009/bwg5000/>



5. Based on percentage cost and time reductions seen in design build case studies estimate reasonable expectation of the time and money which might have been saved on the Maryland General project if design build had been utilized.

Expected Outcome

It is expected that this analysis will result in an easy to use methodology for identifying potential design build candidates. Additionally, it is expected that the potential initial cost, lifecycle cost, and time savings on the Maryland General Hospital project through the use of this delivery method would be substantial.

Course Reference

AE 372: Introduction to Building Industry

AE 472: Building Construction Planning and Management

AE 572: Project Development and Delivery Planning

AE 597D: Sustainable Building Methods



ANALYSIS 2: ENERGY RECOVERY SYSTEM ANALYSIS

Background

The HVAC system of the Maryland General Hospital Central Care Expansion consists of two 380 ton air handling units which supply VAV boxes throughout the building with a constant air temperature. These air handling units on the sixth floor of the addition are feed by two replacement cooling towers and chillers located on the roof of the existing seven story building to the east of the addition. Most of this major mechanical equipment was pre-ordered by the owner so that it would be available for installation on time.

Sustainability is a growing trend in the building industry which should have been a larger concern for this hospital project. Hospitals are large energy consumers partially because of their large outdoor air requirements which requires more air to be conditioned. In recent years, Maryland has seen dramatic increases in the cost of energy as a result of de-regulation of the utility industry in the state.

Opportunity for Improvement

In the current design for the mechanical system dumps all the exhaust air directly to the outside without recovering much of the energy from it before it leaves. Currently the system only utilizes an economizer to attempt to recover some energy from the exhaust air.

Potential Solution

The use of an enthalpy wheel or run around loop could provide energy cost reductions for the hospital. According to the article, "Laboratories for the 21st Century: Best Practices" published by the EPA, there can be significant energy savings through the use of such systems in buildings requiring large amounts of outdoor air. With energy prices on the rise this could prove increasingly beneficial.

Research/Analysis Steps (B1= Breadth 1, CM= Construction Management Analysis)

1. Discuss with the mechanical engineer the design criteria for the system and determine the design conditions. – B1/CM
2. Perform a detailed takeoff and estimate of the major components of the mechanical system. - CM
3. Investigate various enthalpy wheels and heat recovery units which could be utilized for the project. This investigation will compile information such as: -B1
 - a. Efficiency
 - b. Initial Cost
 - c. IAQ Considerations
4. Select a energy recovery system which would be most appropriate based on the results of the investigation and incorporate into the HVAC system design. Evaluate any resizing of other equipment because of this system change. – B1
5. Perform a detailed takeoff and estimate of the major components of the mechanical system. Takeoff any additional pipping and/or ductwork that might required for the system. - CM
6. Obtain quote from the mechanical contractor on the project for the new system and compare to the contract price. - CM
7. Perform lifecycle cost of each system utilizing the initial costs provided by the mechanical contractor and projecting energy and operations costs for each system. - CM
8. Compare each system based on lifecycle cost and constructability to suggest the best option for the hospital. – CM/B1

Thesis Proposal

December 12th 2008

Brian Goodykoontz

Construction Management Option

Advisor: Dr. Anumba

Maryland General Hospital

827 Linden Ave, Baltimore, MD

<http://www.engr.psu.edu/ae/thesis/portfolios/2009/bwg5000/>



Resources

- ASHRAE 90.1 Standard
- BGE – Energy Cost Data
- RS Means

Expected Outcome

This analysis is expected to decrease the load on the AHU equipment to heat and cool the ventilation air for the building. This could result in down-sizing of heating and cooling coils in the ahu and potentially of boilers, chillers. These downsizings could result in savings in initial cost in these areas. It is also expected that the addition of an energy recovery system to the AHU will decrease the hospital's yearly operating costs. This could allow the hospital to spend this money on other important aspects in the hospital

Course Reference

AE 310: Introduction to HVAC

AE 597D: Sustainable Building Methods**

**Integrated BAE/MAE Course

ANALYSIS 3: STRUCTURAL REINFORCEMENT REDUCTION ANALYSIS

Background

The structural system of the Maryland General Hospital Central Care Expansion is a structural steel system because it is tying into the existing structure which is a structural steel system. The addition will infill an existing courtyard six stories and continue across a portion of the existing two story hospital, maintaining a total of six stories (including the existing two stories).

Wide flange columns and beams support the composite flooring system at each level for gravity loads and several braced frames provide support for lateral loads. Column sizes range from W10x33 to W14x61 and span one to three stories. The typical beam size for the operating floor is a W16x31 into a W18x35 or W18x55 girder while the typical beam size for the per-operative floor is a W12x26 into a W12x45 girder. Each of these beams and girders will receive shear studs to allow for 3 1/4" 3000 psi composite slab on metal deck for each floor. Four braced frames constructed from HSS 8x8x5/16 spanning six stories (some through the existing two story building) will provide lateral support for the addition.

To prepare the existing structure for this addition many of the existing columns had to be reinforced with steel plates on either the flange or the web of the column. The most common of these was a 1/2" x 12" plate fillet welded to the flanges of the column. This detail can be seen in Figure 1 below.

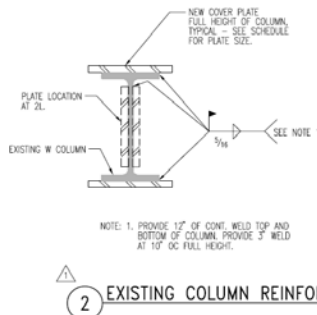

Figure 1: Existing Column Reinforcing Detail

Opportunity for Improvement

The column reinforcement process was evasive to the normal operations of the hospital and required a significant amount of time and money to complete. Each of these column reinforcements required Infection Control Risk Assessment(ICRA) precautions to be taken. These precautions often required double sided gypsum wall partitions floor to floor to provide containment and fire rated wall between work space and hospital. Additionally, each of these spaces required ventilation which could not be tied into the hospital exhaust ducts. These requirements contributed to this process being an expensive and time consuming process costing the project approximately 1.4% of the project cost.

Potential Solution

Design the structural system to decrease the number of columns that need to be reinforced to support the new structure. This will result in a decrease in the will decrease the amount of time and money it takes to reinforce the structure in preparation for the new structure.

Thesis Proposal

December 12th 2008

Brian Goodykoontz

Construction Management Option

Advisor: Dr. Anumba

Maryland General Hospital

827 Linden Ave, Baltimore, MD

<http://www.engr.psu.edu/ae/thesis/portfolios/2009/bwg5000/>



Research/Analysis Steps

1. Create a Revit model of the existing structure – CM - Completed for Tech 2
2. Perform a detailed takeoff and estimate of the structural system – CM – Completed for Tech 2
3. Discuss the design criteria for the structural system with the structural engineer. - CM/B2
4. Perform hand calculations on several bays of the existing structure. – B2
5. Export current structural system from Revit to RAM Structural System to confirm proper operation of the process. – B2
6. Determine several viable options for decreasing the number of columns that need to be supported by the existing structure. –B2
7. Model each of these options in Revit and export to RAM structural system to perform a structural analysis of the structural steel. Select system which minimizes the increase in beam depth. – B2
8. Resize any column reinforcement and footing reinforcement which is necessary to support this new structure. Confirm that column reinforcement and soil bearing are within acceptable limits. – B2
9. Perform hand calculations to confirm the sizing of altered beams and columns in the new structural system. – B2
10. Evaluate how the altered structural system impacts plenum space. Coordination impacts of mechanical, electrical, and pneumatic tubing with the new structural system. - CM
11. Update schedule with altered reinforcement duration. Determine if there was a significant schedule reduction. - CM
12. Perform a detailed takeoff and estimate of the proposed structural system. Utilizing the automated takeoff provided by Revit as was done for technical assignment 2. - CM
13. Compare the two (2) structural systems (designed and this alternative) based on cost, schedule, and hospital disruption during the process. - CM

Tools

- Autodesk Revit Structure
- Bentley RAM Structural System
- Bentley RAM/Revit Link

Resources

- AISC Steel Manual
- Vulcraft Steel Roof and Floor Deck Catalog

Expected Outcome

It is expected that this analysis will result the reduction of column reinforcement necessary in the existing hospital. This reduction the quantity of column reinforcements necessary is expected to reduce the project duration, and cost. This is due to the reduction of timely and costly ICRA containment precautions need to be set up to accomplish the work in each area. Additionally, this quantity reduction could result in less welding necessary to complete the reinforcement of the structure which would also lead to significant time and cost reductions.

Course References

AE308: Introduction to Structural Analysis
AE404: Steel and Concrete Structural Analysis
CE397A: Foundations
AE597F: Virtual Facility Prototyping**

**Integrated BAE/MAE Course



CRITICAL INDUSTRY ISSUE: BIM INTEROPERABILITY

Background

The design process for Maryland General Hospital did not utilize a Building Information Model (BIM); however, a 3D model was created during coordination to assist with the process. This model was coordinated by the mechanical contractor on the project.

At the 2008 PACE roundtable there was a lot of discussion about how BIM is not being used to its full potential in the industry. This was partially attributed to the significant loss of information due to the interoperability process. It was an industry perspective that there needs to be more pilot projects for further investigation of how to successfully implement BIM on projects.

Opportunity for Improvement

The hospital is currently unhappy with their facilities management software because it does not have the full range of functionality that they would like. Additionally, currently the contractual arrangement does not require the use of the model created for the coordination process after the project has been completed, only the two-dimensional coordination shop drawings. This potential loss of intelligence in the model and dissatisfaction of the owner with their facilities management software opens an area for improvement on the project.

Potential Solution

Since the hospital is seeking a new facilities management program and there is already a model that has been created for the MEP coordination process this is a terrific opportunity to investigate the integration of the two entities. This could also afford an opportunity for storage of product data and warranty information directly into this model which interfaces with the facilities management program.

Research/Analysis Steps

1. Create and send a survey to owners, construction management firms, and design firms to develop an industry wide perspective of:
 - a. Broad interoperability
 - b. Specifically with facilities management
2. Seek out several case study examples from the results of this survey and research facilities management implementation. Interview several industry members to gain perspective on the facilities management case studies.
 - a. What was the stage of implementation on the project?
 - b. What software programs were utilized?
 - c. What challenges were encountered?
 - d. What was the cost of implementation on the project?
 - e. What benefits were seen as a result of this interoperability between BIM and facilities management software?
 - f. What information was included in the model which was carried over to the facilities management software?
3. Compile and summarize the findings of the survey and interviews.
4. Develop a guide for implementation of the BIM to Facilities Management interface on projects.
Maryland General Hospital Case Study
5. Research various facilities management programs available on the market.

Thesis Proposal

December 12th 2008

Brian Goodykoontz

Construction Management Option

Advisor: Dr. Anumba

Maryland General Hospital

827 Linden Ave, Baltimore, MD

<http://www.engr.psu.edu/ae/thesis/portfolios/2009/bwg5000/>



6. Discuss with facilities manager potential facilities management software programs and expected functionality of a potentially new software package which could incorporate the pre-existing
7. Customize a guide for implementation of a BIM to Facilities Management Program on the Maryland General Hospital Project
8. Identify challenges faced and lessons learned on the project.

Expected Outcome

It is expected that this research will result in a greater understanding of the interoperability challenges which are faced in the industry. A guide for implementation of facilities management software on projects at varying stages will be developed from information obtained in each of the case study examples.

Resources

Potential Case Study Sources

- John Bechtel - Office of the Physical Plant
- Jeff Brightman - Bechtel
- Dr. John Messner

Course Reference

AE597F: Virtual Facility Prototyping

**Integrated BAE/MAE Course

Thesis Proposal

December 12th 2008

Brian Goodykoontz

Construction Management Option

Advisor: Dr. Anumba

Maryland General Hospital
827 Linden Ave, Baltimore, MD

<http://www.engr.psu.edu/ae/thesis/portfolios/2009/bwg5000/>



BIBLIOGRAPHY

"Laboratories for the 21st Century: Best Practices." Environmental Protection Agency. October 2003. 12 Dec 2008.
<http://www.epa.gov/lab21gov/pdf/bp_recovery_508.pdf>.

Riley, D. Sanvido, V. Horman, M. McLaughlin, M. Kerr, D (2005). "Lean and Green: The Role of Design-Build Mechanical Competencies In the Design and Construction of Green Buildings." ASCE Construction Research Conference. April 5-7, San Diego, CA.

Thesis Proposal

December 12th 2008

Brian Goodykoontz

Construction Management Option

Advisor: Dr. Anumba

Maryland General Hospital

827 Linden Ave, Baltimore, MD

<http://www.engr.psu.edu/ae/thesis/portfolios/2009/bwg5000/>



Appendix A: Weight Matrix

This weight matrix demonstrates how time will be spent conducting preparing this senior thesis research and analysis.

Description	Research	Value Engineering	Constructability Review	Schedule Reduction	Total
Delivery Method Analysis	5	5	10	0	20
Heat Recovery VE	5	15	5	0	25
Structural Reinforcement Schedule Reduction	0	0	15	15	30
Critical Industry Issue: BIM Interoperability	20	5	0	0	25
Total	30	25	30	15	100

Thesis Proposal

December 12th 2008

Brian Goodykoontz

Construction Management Option

Advisor: Dr. Anumba

Maryland General Hospital
827 Linden Ave, Baltimore, MD

<http://www.engr.psu.edu/ae/thesis/portfolios/2009/bwg5000/>



Appendix B: Research/Analysis Schedule

The attached schedule depicts the research and analysis stems will be achieved throughout the spring 2009 semester.



Appendix C: Breadth Studies

Structural Breadth

I will perform calculations on the existing structure utilizing the structural analysis program, RAM structural system. This will be completed by exporting my model from Autodesk Revit Structure to the analysis program (this process was researched and documented as part of a team project for my virtual facilities prototyping class). I will perform hand calculations and member sizing to confirm that the program is properly functioning. Once this is complete I will redesign a portion of the system in an attempt to reduce the number of columns necessary to support the new structure. I will utilize the analysis program to quickly check and size different options. Additionally, any increased reinforcement at remaining columns and footings will be calculated as part of this study.

Mechanical Breadth

I will research the various options for heat recovery that are currently available on the market. I will evaluate each based on the design criteria for the project and efficiency keeping in mind that indoor air quality is a top concern. Utilizing this research I will select the best system for the project and incorporate it into the mechanical design. I will then perform an energy analysis utilizing this new system to determine the amount of energy saved through the use of such a system. Additionally, I will investigate if any subsequent upsizing of fans and downsizing of chillers and boilers which could result from this change in the system.

Week			Delivery Method Analysis	Energy Recovery System VE	Structural Reinforcement Reduction	Critical Industry Issue	
	12/29	1/4				Create/Send Survey	
0	1/5	1/11	Case Study Research	Discuss design criteria	Discuss Design Criteria	Case Studies/ Interviews	
1	1/12	1/18	Case Study Research	Detailed Takeoff & Estimate Exist	Hand Calcs/ Export & Analyze	Case Studies/ Interviews	
2	1/19	1/25	MGH Mech Contract Research	Research Potential Systems	Potential Viable Options/ Model	Interviews	
3	1/26	2/1	MGH Mech Contract Research	Select, Incorporate	Hand Clacs/ Export & Analyze	Research FM Software	
4	2/2	2/8	Develop Rubric	Equipment Resizing	Column and Footing Reinforcemen	Compile and Summarize	
5	2/9	2/15	Develop Rubric	Detailed Takeoff & Estimate Prop	Coordination Implications	Develop Guide	
6	2/16	2/22	Evaluate MGH Based on Rubric	Subcontractor Quote	Duration Calculations and Schedu	Customized MGH Guide	
7	2/23	3/1		Lifecycle Cost Analysis	Detailed Takeoff & Estimate Prop.		
8	3/2	3/8	Cost and Duration Reduction	Comstructability of Proposed	Compare	Identify Challenges and LLs	
9	3/9	3/15	**SPRING BREAK... Write the Final Report... SPRING BREAK**				
10	3/16	3/22	Proofread Final Report				
11	3/23	3/29	Create Presentation				
12	3/30	4/5	Practice Presentation				
13	4/6	4/12	Present				