

Technical Report 2

The University Medical Center of Princeton

10/19/2011

Faculty Advisor: Professor Parfitt

Alexander J. Burg

Structural Option

The Pennsylvania State University



Executive Summary

This document includes information regarding the overview of the building and an in-depth analysis of three alternate designs for the University Medical Center at Princeton (UMCP) floor systems. The typical bay size for the UMCP building is 26'x29', but this bay size varies for all three redesigned systems. The floor systems compared are:

- Flat Slab with Drop Panels
- Solid One-Way Slab with Beams
- Pre-Cast Hollow Core Concrete on Steel Girders

For the flat slab system, the design has a simple bay size of 22'x22'. The thickness of the slab resulted in 7.5". To design the reinforcement and panel dimensions, the 2008 Concrete Reinforcing Steel Institute (CRSI) Design Handbook was utilized. A more in-depth detail on the design is given in the report and in Appendix 1. This system was the most cost-effective, easily constructible, and has the maximum floor to ceiling height.

A solid one-way slab with beams came out to be the lightest system, with a typical bay size of 17'x17'. With only one infill beam and only 4" slab thickness the floor to ceiling thickness is ideal. The constructability is as simple as the flat slab system and only cost about \$2.00/ft² more. This would also have less of an impact of the foundation since it is the lightest alternative floor system.

A pre-cast hollow core system was designed for easy construction and workability. This design turned out to be more expensive than the other systems but less than the original design. The Grid system for the columns only changed in the East/West direction. The deflection for this was very high compared to the rest of the systems, which is not ideal for hospital occupancy.

Contents

Executive Summary..... 1

Building Introduction 3

Structural Overview 4

FOUNDATIONS 4

FLOOR & FRAMING SYSTEMS..... 4

LATERAL SYSTEMS..... 5

CODES/MEANS USED..... 6

Gravity Loads..... 7

DEAD LOADS..... 7

LIVE LOADS..... 8

Existing Floor System - Composite Steel Deck 8

Alternative Floor System 1- Flat Slab with Drop Panels 9

Alternative Floor System 2- Solid One-Way Slab with Beams 11

Alternative Floor System 3- Hollow Core Concrete on Steel Beams 13

System Comparison 14

STRUCTURE OVERVIEW..... 14

ARCHITECTURE 14

CONSTRUCTABILITY 15

COST 15

Conclusion..... 16

Appendices..... 17

 Appendix 1: Architectural Sections & Plans..... 18

 Appendix 2: Existing Design 20

 Appendix 4: Flat Plate with Drop Panels..... 24

 Appendix 5: Solid One Way Slab 26

 Appendix 6: Hollow Core Concrete 28

 Appendix 7: RS Means 31

Building Introduction

Princeton University Medical Center was in a big need of change. The rapid growth of people plus the outdated building design and equipment were the main reasons to upgrade their old medical center.

The University Medical Center at Princeton (UMCP) will also be joining the Pebble Project. Pebble Project is a research effort between The Center for Health Design and selected healthcare providers to measure the layout and design of a hospital and how it can increase quality care and economic performance. The design of this building is not just for looks, but to help operate a hospital in a healthy and efficient manner.

This six story tall building has a long and curving body that encases the parking lot to draw people into the building. Lighting is not going to be an issue during the day as the glass curtain wall is used on the south face of the building. Furthermore, it will provide a view to the outside for all the patients and workers in the building. The curtain wall is framed with aluminum reliefs and metal panels. The West and East elevations have a CMU ground face with a brick façade on the top floors, and there are very few windows since these walls are framed with steel bracing. The mechanical equipment is encased in 13.5' parapets. Floors two through six almost mimic each other in framing and room layout. The entrance of the building has a wide atrium open to the second floor with interior wood shading panels. The overall design of the building is simple, sleek, and efficient.



FIGURE 1: UMCP SITE LOCATION SHOWN IN BLUE SATELLITE PHOTO COURTESY OF GOOGLE MAPS

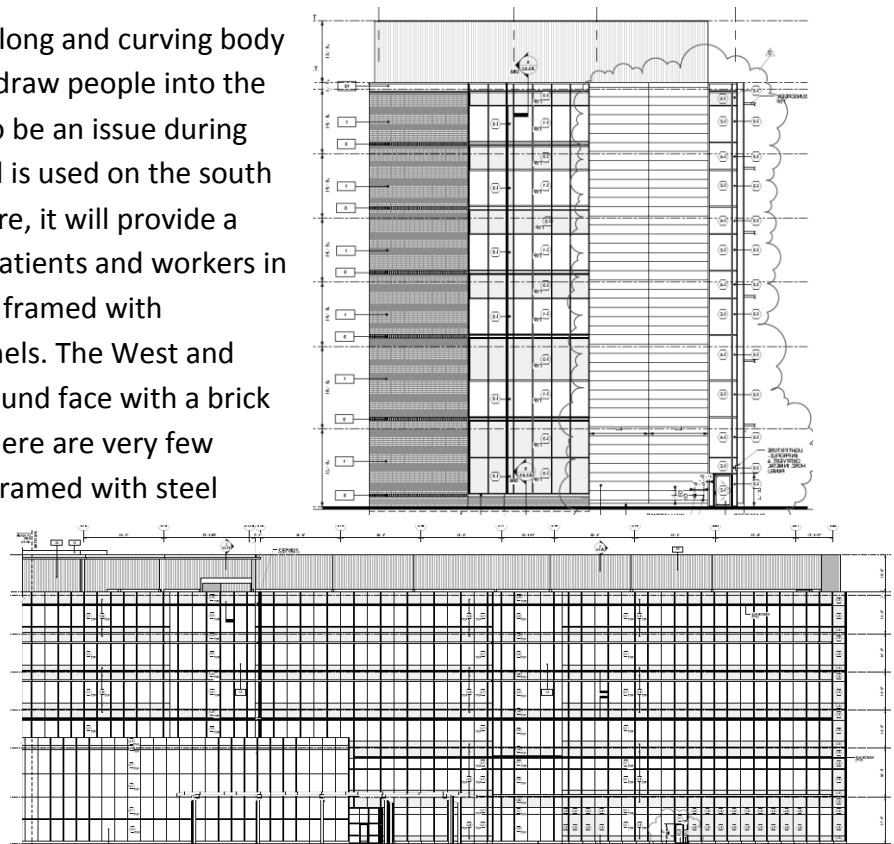

FIGURE 2: EAST AND SOUTH BUILDING ELEVATIONS DRAWINGS COURTESY OF TURNER CONSTRUCTION

Structural Overview

The foundation plan for the University Medical Center is built on 4" to 5" Slab-On-Grade basement floor with interior concrete piers stabilizing wide flange columns, and an exterior 2' thick foundation wall partially incasing mini tension piles. The design of the superstructure is primarily steel framing. The framed floors consist of a 3 span 3 ¼" lightweight concrete composite decking system with composite steel framing. Roof decking is type B 1 ½" galvanized metal deck, and 6 ½" normal weight concrete composite metal deck for the roof Penthouse area. There is also a massive curtain wall spanning the South end of the curving building, but this will not be analyzed in this technical report.

FOUNDATIONS

According to drawing S3.01 all the subgrade footings were poured under the supervision of a registered Soils Engineer. The capacity of the soils, shown in the boring test specifications, came out to be 4,000psf and 8,000psf for the compacted/native soils (medium-dense/stiff) and decomposed bedrock respectively. The spread footings erect wide flange columns, varying from W10x54 to W14x311, to anchor the superstructure (Refer to Figure 3 for more detail). The spacing for the foundation columns is not consistent throughout the basement, which that is the reason for the varying column sizes. Figure 3 shows a typical spread footing supporting a steel column. Outlying the basement is a 2' thick foundation wall with mini tension piles that relives up to 150kips of tension from the concrete bearing wall.

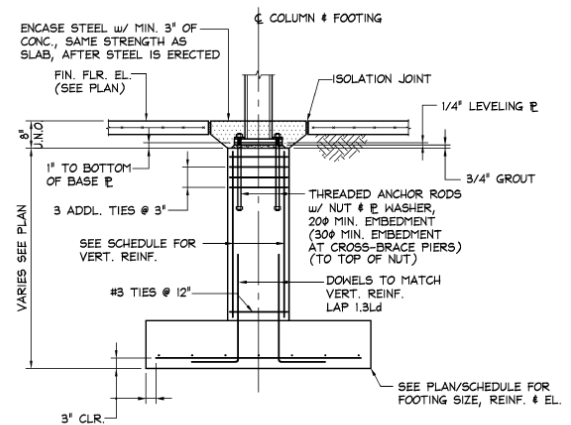

TYPICAL COLUMN FOOTING WITH PIER

FIGURE 3: TYPICAL COLUMN FOOTING WITH PIER
DRAWING COURTESY OF TURNER CONSTRUCTION

Concrete Strengths:

- 3,000psi- Spread Footings, Wall Footings, Foundation Wall, & Retaining Walls
- Minimum of 3,000psi- Piers-match wall strength
- 3,500psi- Slab-On-Grade

Rebar Design:

- ASTM A615- Deformed Bars Grade 60
- ASTM A185- Welded Wire Fabric

FLOOR & FRAMING SYSTEMS

A typical beam spanning in the North/South direction, consists of a 26' span then a 15' span, and finally back to a 26' span. The East/West girders span 29 ½' typically. Floors two through six

do not change in design other than the column thickness, all of the floors use a 3 span 3 ¼” lightweight concrete composite decking. This creates a one-way composite flooring system connected to composite beams. Even though the first floor has an additional atrium, the decking is still consistent to the floors above. Figure 4 shows the wide flange beams used in each span.

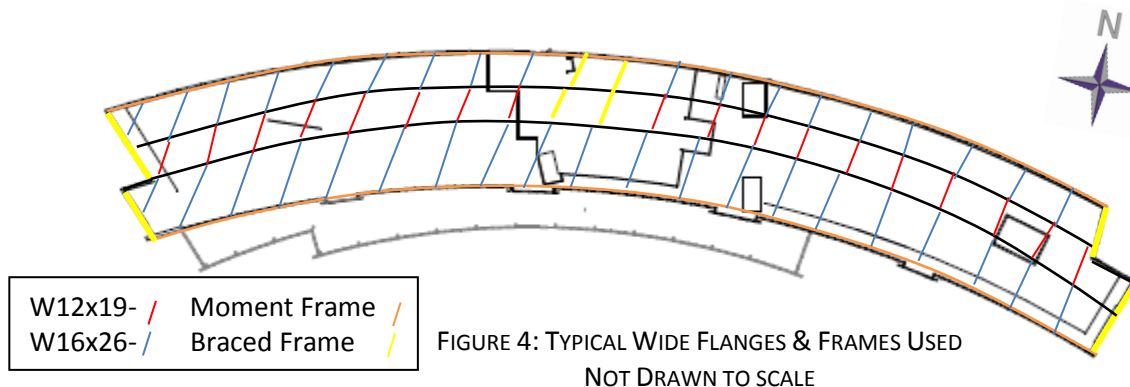

The infill beams are usually at a spacing of 9.8’ and they range from W16x26 for the 26’ spans or W12x19 for the 15’ spans. The girders typically span 29.5’ and vary from W24x55 on the exterior girders to W21x44 on the interior girders. These composite beams use ¾” bolts to help anchor the decking. The typical bays then come out to be either 29.5’x26’ or 29.5’x15’. There are also two transfer beams on the on column lines N2 and S3 to account for columns that do not line up on the first to second floor.

Steel Design:

- ASTM A992- Wide Flanges
- ASTM A500- Rectangular/Square Hollow Structural Sections Grade B, Fy=46ksi
- ASTM A500 or ASTM A53- Steel Pipe Type E or S Grade B
- ASTM F1554- Anchor Rods Grade 55

LATERAL SYSTEMS

The UMCP lateral systems design was comprised of typical steel moment frames in the East/West direction and steel concentrically braced frames in the North and South direction. Those framing systems only occurred on the perimeter of the building. Around the elevator shaft is another place where the design is concentrically braced. The lateral forces will travel into the composite deck, and then through the wide flange beams or HSS braces into the columns to the piers to then dissipate into the ground.

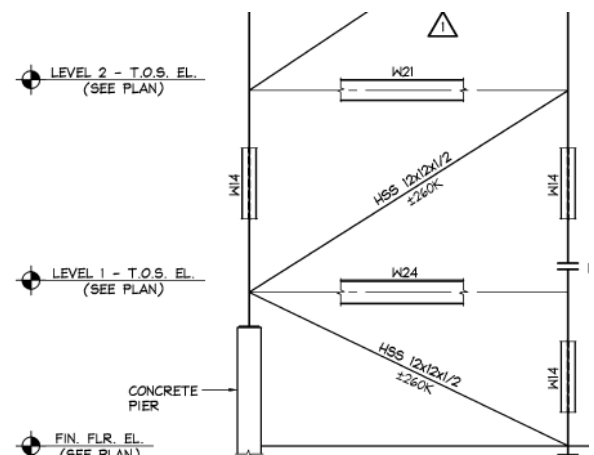

FIGURE 5: TYPICAL BRACED FRAME COURTESY OF TURNER CONSTRUCTION

CODES/MEANS USED

This building fit into an Occupancy Category III. Any Hospital/Medical Center needs to be designed with an Occupancy Category III as a safety factor.

Original design codes used on this building were:

- 2006 International Building Code (IBC) with New Jersey Uniform Construction Code
- 2006 International Mechanical Code (IMC)
- 2005 National Electric Code (NEC) with local amendments
- 2006 International Energy Conservation Code with other local amendments
- 2006 International Fuel Gas Code with local amendments
- New Jersey Department of Health and Senior Services - "Licensing Standards for Hospitals, N.J.A.C 8.43G" and the 2006 Edition - "Guidelines for Design and Construction of Hospital and Health Care Facilities."

Design codes used for Thesis Calculations:

- ASCE 7-10 Minimum Design Loads for Buildings and other Structures
- American Institute of Steel Construction, 14th Edition AISC Steel Construction Manual
- 2008 Vulcraft Steel Roof & Floor Deck Manual
- 2008 Concrete Reinforcing Steel Institute (CRSI) Design Handbook
- 2012 RS Means Assemblies Cost Data
- American Concrete Institute (ACI) 318-08

Gravity Loads

The UMCP structure was designed by O’Donnel & Naccarato, Inc. using the 2006 International Building Code with New Jersey Amendments. For the thesis calculations performed, ASCE7-10 was used to determine the snow, dead, and live loads. Every calculation was performed by using the LRFD method, and in later tech reports these checks will be analyzed on a computer modeling system.

DEAD LOADS

The roof dead loads for the mechanical equipment were assumed to be 150psf since there were multiple pieces of equipment weighing more than 15,000 pounds. The metal decking used for the roof did not add too much weight to the roof, only about 1.27psf. A framing allowance for the steel system was assumed to be 10psf for the roof and every other floor. Decking weight for the roof and the composite decking weight for the floors were taken out of the Vulcraft Steel and Roof Decking manual. Though, the decking for UMCP was manufactured by United Steel Inc. The decking was the same for all six floors, and it weighed 39.5psf. The composite beam check turned out to be the same that was designed to. The check for the girder and columns turned out to be a little different, which could be from the assumed weights or also using the newest codes and standards. The girder came out to be a W21x62, but was designed at a W24x62. This difference could be from different design practices and different loads assumed.



FIGURE 7: TYPICAL BAY USED FOR SPOT CHECKS
 COURTESY OF TURNER CONSTRUCTION

LIVE LOADS

Chapter 4 of ASCE7-10 provided the live loads for operating rooms, patient rooms, and corridors above first floor as 60psf, 40psf, and 80psf respectively. For the spot checks the spans crossed to different occupant rooms, so whichever occupancy had the higher live load is the one load that controlled. None of the tributary areas are big enough to use live load reduction factors.

Floor Live loads	
Area	ASCE7-10 Loads
Lobby/Corridor 1 st Floor	100psf
Corridors above 1 st Floor	80psf
Operating Rooms	60psf
Patient Rooms	40psf

Existing Floor System - Composite Steel Deck

The original design of the floor system in the UMCP building is composite steel with a bay size of 29.5'x26.0' and the beams are spaced at 9'-10". All the bay sizes are the same for all the framed stories. A three span 3 ¼" composite steel deck is the existing structure for each floor. To help anchor the concrete slab to the 18 gage galvanized steel deck, ¾" bolts are utilized to make the structure act compositely. The design beam size is a W16x26 and a W24x55 for the girder sizes. Refer to figure 8 for the existing floor design.

Composite Steel Deck Design	
f'c:	4,00 psi
Concrete Type:	Lightweight Concrete
Slab Thickness:	3 ¼"
Bolt Size:	¾"
Bay Size:	29.5'x26.0'
Steel Deck:	18 gage galvanized
Beam Size:	W16x26
Girder Size:	W24x55

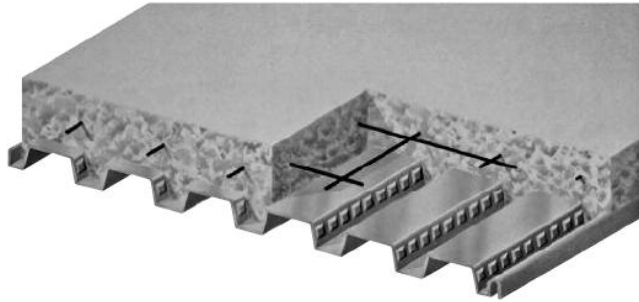
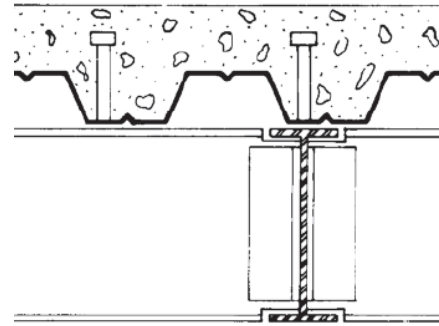

FIGURE 8: TYPICAL BAY COMPOSITE SECTION
COURTESY OF VULCRAFT



ADVANTAGES

- Fast construction
- Not a very thick slab
- Works well with heavy loading on long spans
- Reduced weight

DISADVANTAGES

- Additional cost for shear connectors
- Medium lead time requires for steel members
- Spray on fireproofing required
- High floor to floor height

Alternative Floor System 1- Flat Slab with Drop Panels

The first alternative design was a two way flat slab with drop panels. The flat slab design has a lot of mass in the floor structure to help with deflection/vibration concerns. Another advantage to this design was that concrete is cheaper than steel, and placing this system is not labor intensive therefore cheap. Drop panels were designed to keep the slab thin and still remain adequate for punching shear. This keeps the floor to ceiling height low.

The minimum slab thickness was designed from table 9.5C in ACI 318, and it was designed as a 7.5" slab. The design of the column layout changed to three rows of continuous 22'x22' bays to help with easy construction and reusable framing. After determining the superimposed dead load the slab was designed using the Concrete Reinforcing Steel Institute (CRSI) design handbook to determine the size of the rebar, square column dimensions, and the size of the drop panels. The design is shown in the table below, and you can also check the calculations used in appendix 4.

Interior Flat Slab Panel with Drop Panels Design		
f'c:	4,000 psi	
Bar Grade:	Grade 60	
Slab Thickness:	7.5"	
Bay Size:	22'x22'	
Square Columns:	17"x17"	
Square Panels:	Depth=4.25"	Width=7.33'
	<u>Top</u>	<u>Bottom</u>
Column Strip:	(13) #5	(15) #4
Middle Strip:	(11) #4	(10) #4

Exterior Flat Slab Panel with Drop Panels Design		
f'c:	4,000 psi	
Bar Grade:	Grade 60	
Slab Thickness:	7.5"	
Bay Size:	22'x22'	
Square Columns:	15"x15"	
Square Panels:	Depth=4.25"	Width=7.33'
	<u>Top</u>	<u>Bottom</u>
Column Strip:	Ext: (12) #4, Int: (14) #5	(22) #4
Middle Strip:	Int: (12) #4	(10) #5

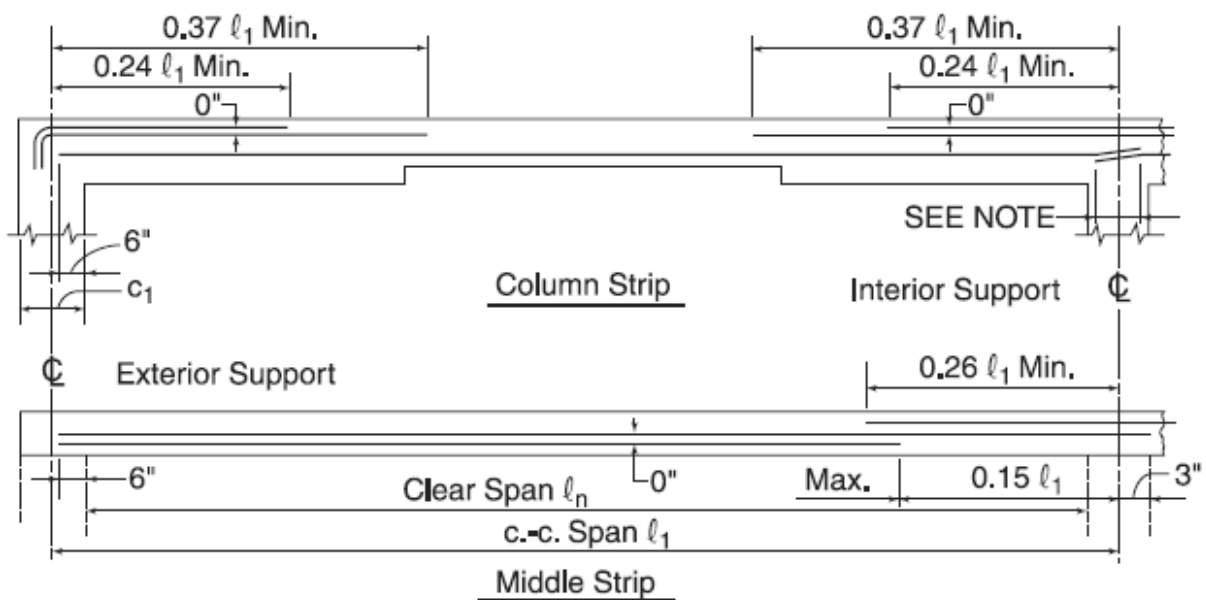

FIGURE 9: TYPICAL REINFORCEMENT
COURTESY OF CRSI

ADVANTAGES

- Good for vibration criteria
- Simple construction and formwork
- Works well with heavy loads on long spans
- Thinner floor to ceiling heights

DISADVANTAGES

- Increased self-weight
- Not easily able to punch through a two-way reinforced slab for mechanical equipment
- Asymmetric ceiling with the drop panels

Alternative Floor System 2- Solid One-Way Slab with Beams

Many of the same design reasons for the one-way slab with beams are similar to the flat slab with drop panels. Concrete cost is low because the thickness of the slab is relatively small, and there is only one infill beam. However this system will cost more due to frame work and labor needed.

For this floor system, the column grid changed from the 26'x29.5' original design to a 17'x17' bay. Now there are four rows of columns. Since the spans are not very long the columns will not be as thick since there are so many. The columns could then be easily hidden or work well in an open floor plan design. The thickness of the slab was determined, by table 9.5A in ACI 318, to be 4" thick. The spacing was designed to center the 17' span, making the spacing of the beams 8.5'. After calculating the superimposed load, to design the reinforcement the CRSI design manual was used. After finding the depth of the beam and the girder to be 12" and 14" respectively, from table 9.5A in ACI 318, the CRSI manual was utilized to help design the beam and girder reinforcement. The table below shows you the design criteria for the second alternative system.

Solid One-Way Slab Design	
f'c:	4,000 psi
fy:	60,00 psi
ρ:	0.0050
Bar Grade:	Grade 60
Slab Thickness:	4"
Bay Size:	17'x17'
Beam Spacing:	8.5'
Top Bars:	#3 at 12" spacing
Bottom Bars:	#4 at 12" spacing
Temperature Shrinkage Bars:	#3 at 11" spacing

Beam Design

f'c:	4,000 psi
fy:	60,00 psi
Bar Grade:	Grade 60
Beam Thickness:	12"
Beam Width:	10"
Bay Size:	17'x17'
Beam Spacing:	8.5'
Top Bars:	(2) #7
Bottom Bars:	(2) #6
Open Stirrups:	(18) #3: 1@2", 17@4" Each End

Girder Design

f'c:	4,000 psi
fy:	60,00 psi
Bar Grade:	Grade 60
Beam Thickness:	14"
Beam Width:	12"
Bay Size:	17'x17'
Girder Spacing:	18'
Top Bars:	(2) #7
Bottom Bars:	(2) #6
Open Stirrups:	(14) #3: 1@2", 13@5" Each End

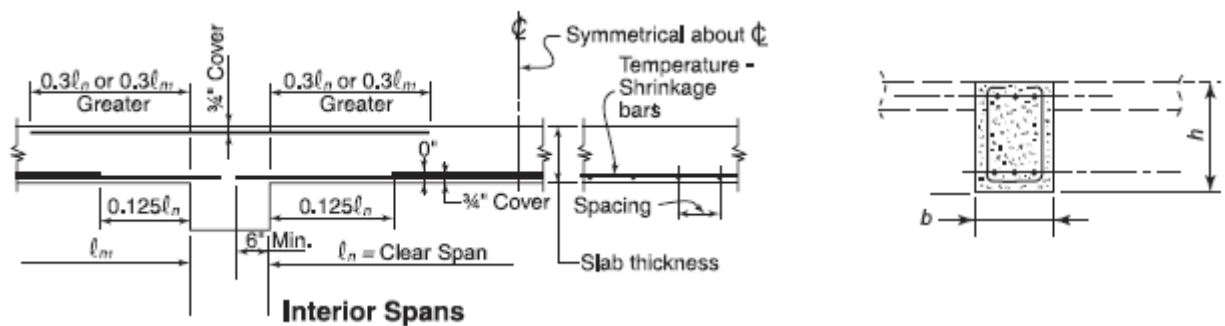

FIGURE 10: TYPICAL REINFORCEMENT
COURTESY OF CRSI

ADVANTAGES

- Shallow members
- Maximizes floor to ceiling height
- Reduced weight for thinner slab

DISADVANTAGES

- Asymmetric ceiling with the beams
- Slow Construction
- Column spacing effect architecture design

Alternative Floor System 3- Hollow Core Concrete on Steel Beams

The hollow concrete core system was designed to be easy to use and place. Also the steel beams with the hollow core planks is not too thick, and you could also show of the bottom structure if need be. In this floor system the North to South column spacing stayed the same.

To design the hollow concrete core systems, Nitterhouse products were applied. The cut sheet used for the design is located in appendix 6. Nitterhouse supplies a table to design what span of certain types of hollow core concrete at specific loads. With a fire rated design of two hours, the plank type that could withstand was a 6"x4'-0" hollow core plank with a 2" topping. The longest span able to hold the load is 18'. The beams were sized including the superimposed dead load weight and the weight of the precast planks. The 14th edition of the ASCE Steel Manual was used to find the beam size which was controlled by deflection. The table below shows the design layout of the system.

Prestressed Concrete with Wide Flange Beam	
Topping Thickness:	2" (Fire rating 2 hours)
Thickness:	6"
Width:	4'
Strand Pattern:	(6)-1/2" Dia.
Span:	18'
W-Flange:	W24x55

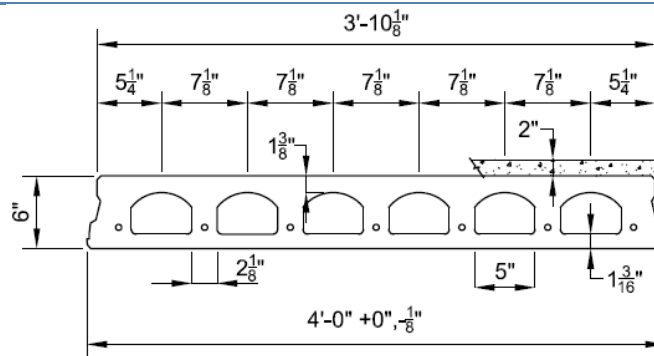

FIGURE 10: HOLLOW PLANK COURTESY OF NITTERHOUSE

ADVANTAGES

- Fast and easy construction
- Open or closed ceilings
- Great insulator for sound and heat transmission
- Lightweight
- Sustainable

DISADVANTAGES

- Variance in column grid
- Long lead time
- Deep girders required
- Not good for vibration criteria

System Comparison

STRUCTURE OVERVIEW

The alternative systems that were used were primarily of concrete design. A non-composite system was compared to an alternative system because it is not commonly used in today's building industry. Also, post-tension concrete systems were not used since the shape of UMCP building is curved. While using the concrete for most of the design increased the weight of the structure increased inevitably, this could cause issues with the foundation system not being adequate due to the extra weight. The soil strength would be fine, but the footing may need to be sized to a larger dimension. This will be looked into further upon research. Deflection was greatly impacted in the concrete structures, except for the hollow core planks since they are supported by steel girders. The lateral system may need to be redesigned for all the alternative systems.

ARCHITECTURE

All of the column layouts changed in the alternative designs, which could change the design of the floor plans. The flat slab and one-way slab systems now have a square column layout. This new layout could be easy to incorporate into the wall due to small column sizes. Designing the columns to be shown in an area is not unusual and sometimes pleasing. The column spacing for the hollow core planks has the same three rows as the original design in the North/South direction, but decreased the spacing in the West/East. The flow of the design would not have to vary by much if this system was in use, besides the fact that the floor to ceiling height would increase. For the flat slab with drop panels and the one-way slab with beams the floor to ceiling height decreases.

CONSTRUCTABILITY

Constructing these alternative systems would be a fairly simple project. The flat slab with drop panels and the one-way slab with beams would have very simple formwork, and reusable materials for framing. The hollow core concrete would be very fast to construct after erecting the steel girders. Since the hollow core concrete is precast you also wouldn't have to wait for them to dry.

COST

The cost could be the biggest driving factor on which system to use, but the original design shows that it was not. The 2012 RS Means Assemblies Cost Data was a somewhat vague, to view the page where the prices were found go to appendix 7. The estimates didn't take into account a couple factors such as location. The estimates still should be in true in which system is pricier than the next since they are all consistent with each other. A more in depth cost analysis will be complete to guarantee that the correct system is chosen.

	Composite Steel (Original Design)	Flat Slab with Drop Panels	One-Way Slab with Beams	Pre-Cast Hollow Core Planks
Slab Thickness:	3"	7.5"	4"	6"
Total Thickness:	26.6"	11.75"	18"	29.6"
Self-Weight:	39psf(slab & Deck)	95.98psf	51.25psf	73.75psf
Column Grid	No	Yes	Yes	Yes
Impact:				
Fireproofing:	2 hr. spray on	2 hr.	2 hr.	2 hr. spray on
Deflection:	0.72"	0.52"	0.21"	0.74"
Cost:	\$28.25/ft ²	\$15.85/ft ²	\$17.71/ft ²	\$24.10/ft ²
Future Investigation:	Yes	Yes	Yes	Yes

Conclusion

After analyzing three different floor systems, many different pros and cons for each system were found. Each floor system has their own uniqueness to them that makes each one a feasible design, but some more than others. Most of the systems were designed using the CRSI manuals which are really conservative, but keeping the consistency made comparing the systems simple and easy.

The flat slab with drop panels shows the system is the most cost-effective design out of all three of the alternative systems. The layout of the columns changed, but made the grid system very simple. This lengthened the floor to ceiling height as well. Also, constructing this system would be very easy. This is also a good system if the occupancy level of the floor changes for any reason.

A one-way slab system with beams would weigh less than the flat slab with drop panels, which would have less of an effect on the foundation. This was not taken into the account of the cost estimate, but it will indefinitely change the price of the whole system. The floor depth does not increase much from the flat slab with drop panels. The one way slab only has one infill beam as well, leaving a lot of room with a flat ceiling of just a 4" thick slab. The cost is not much higher than the flat slab with drop panels.

Analyzing and designing a hollow core concrete on steel girders came to be more expensive than the other two different systems, but less than the original system. The column grid system only varied in the East/West direction which may not have much of an effect on the architecture of the building. Moisture content is able to build up inside the core, which can cause long-term maintenance issues. Also the deflection for the hollow core system was very large compared to the other two systems.

All of these systems seem viable to be used for the UMCP building. The best system in the research so far would be the flat slab system for cost and efficiency reasons. Though, the one-way slab could save on foundation cost. These foundation and lateral system concerns will be further researched for future reports.

Appendices

Appendix 1: Architectural Sections & Plans

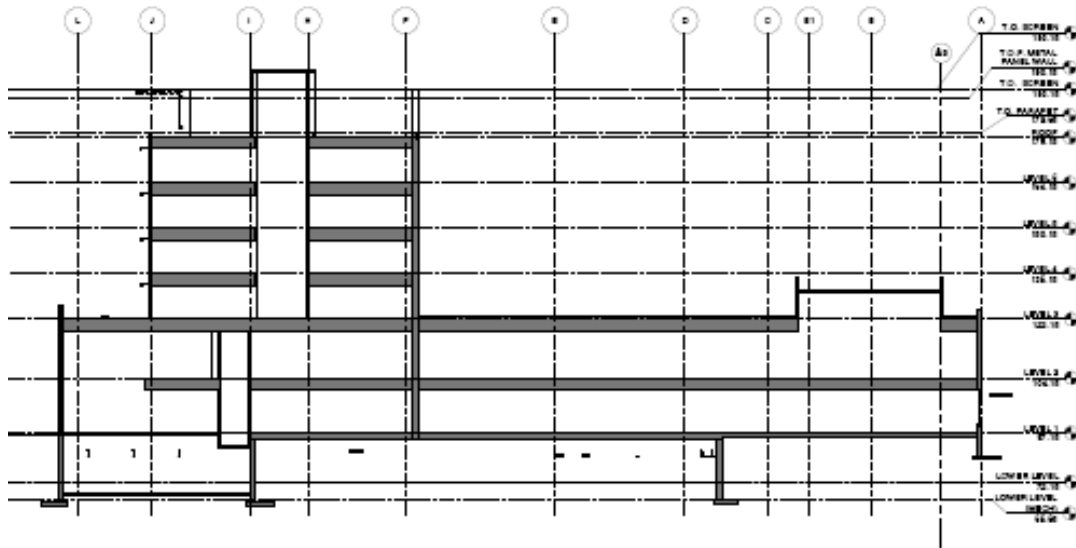

EAST/WEST SECTION

COURTESY OF TURNER CONSTRUCTION

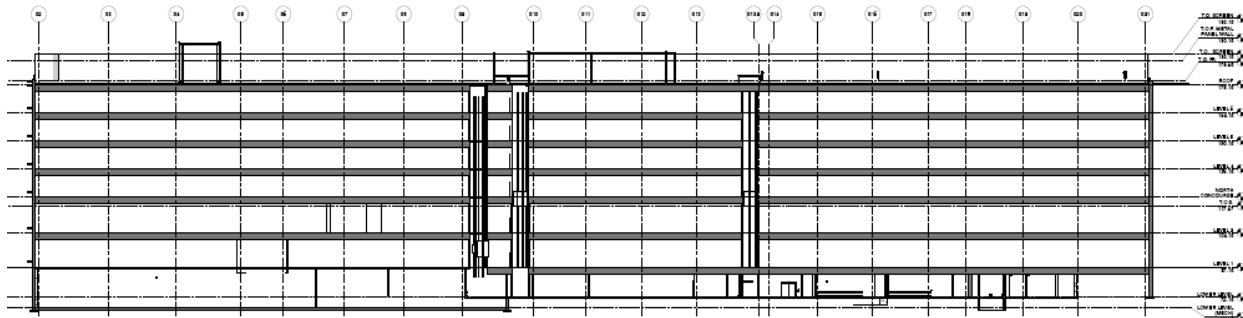

NORTH/SOUTH SECTION

COURTESY OF TURNER CONSTRUCTION

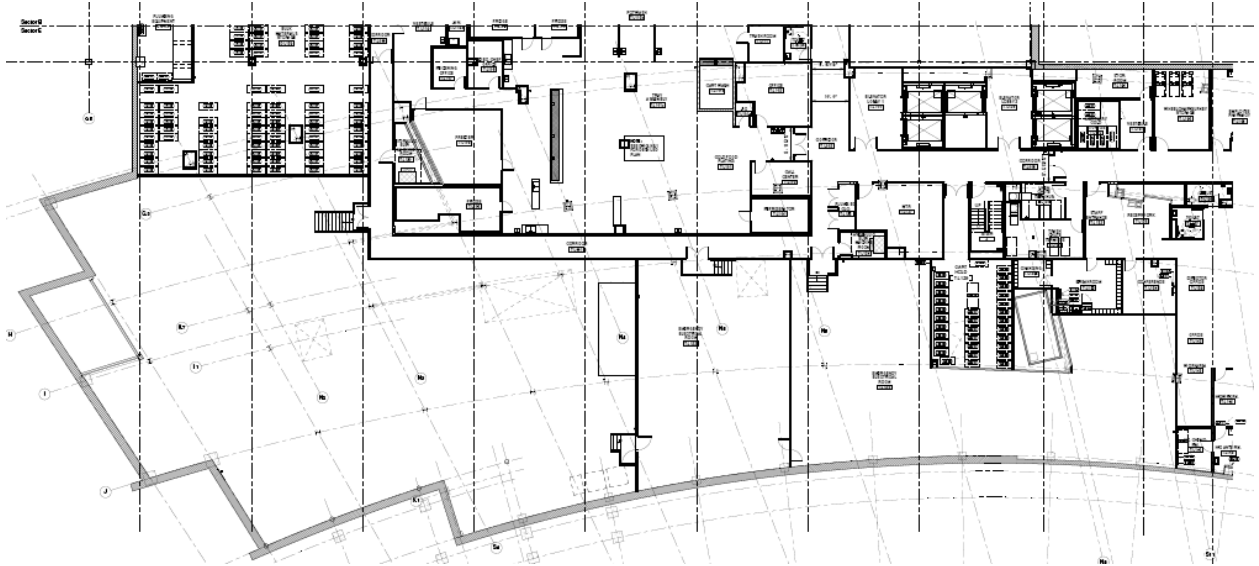

TYPICAL WEST END FLOOR PLAN

COURTESY OF TURNER CONSTRUCTION

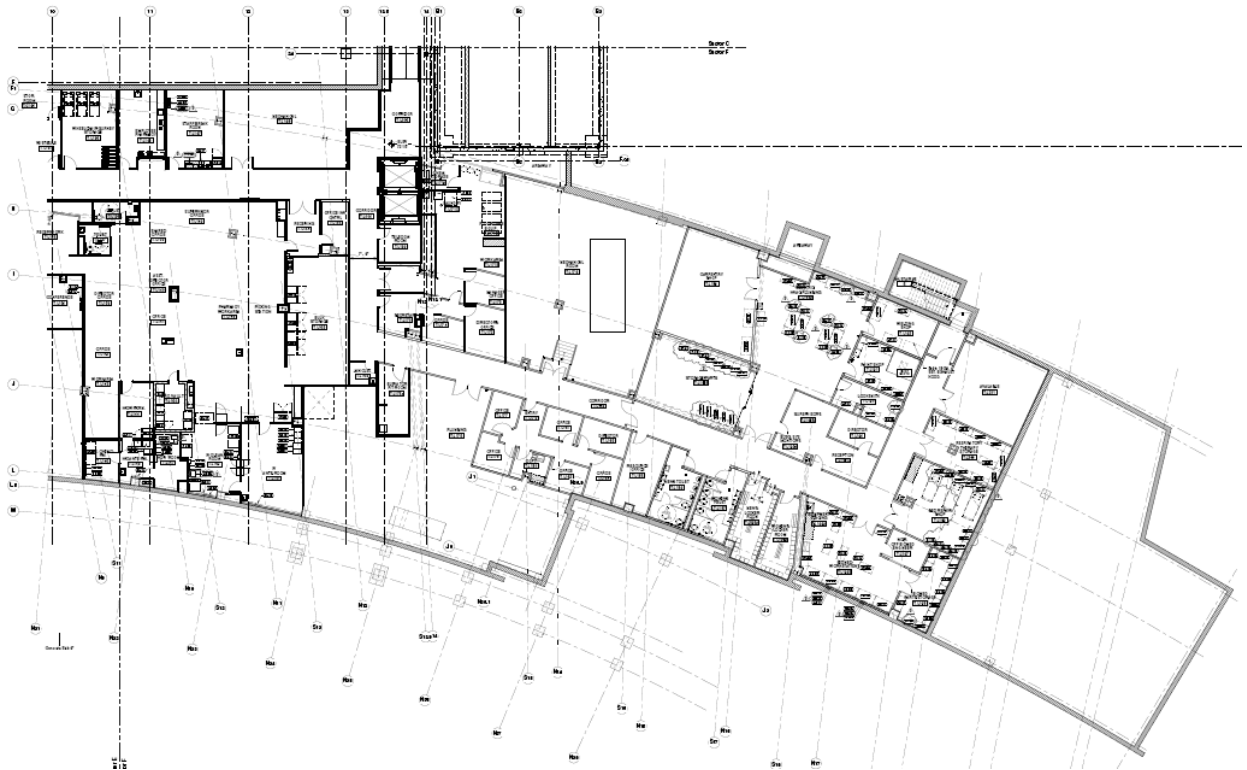

TYPICAL WEST END FLOOR PLAN

COURTESY OF TURNER CONSTRUCTION

Appendix 2: Existing Design

Deck + 1/4

Alex Burg Tech. Report 1 2nd Floor Composite Beam Deck

The tributary area was taken from the back left corner of U.M.C.P since this is where the greatest spans are.

Span = $\frac{32.167'}{3}$

Span = $10.72' \approx 10.9'$

Fire Rating \rightarrow 2 Hr. Unprotected Deck Use: $3\frac{1}{2}''$ LL, 1.5VL

$A_c = 10.72' \times 26.3' = 282.3 \text{ ft}^2$

$L_L = 80 \text{ psf}$

Super. insulat. Deck = 20 psf

MEP Load = 15 psf

Total Weight = 135 psf \rightarrow Use: 1.5VL R19 $\tau = 3''$

Slab + Deck weight = 39 psf

$W_u = (1.2(15 + 20 + 39 + 10) + 1.6(80)) \times 10.72 = 2.8^k$

Beam

Max Moment

$M_u = \frac{w_u L^2}{8} = \frac{2.8 (26.3)^2}{8} = 242.1^k$

Assumed 1 stud/rib weak position

$f_c = 4000^k, 3/4'' \phi$

$Q_h = 17.2^k \rightarrow$ Table 3-21

$Y_2 = \tau - \frac{1}{2}$
 $Y_2 = 3 - \frac{1}{2} = 2.5''$

assume $a = 1''$

Max Shear

$V_u = \frac{w_u L}{2} = \frac{2.8 (26.3)}{2} = 36.8^k$

<p style="font-size: small;">3-0235 — 50 SHEETS — 5 SQUARES 3-0236 — 100 SHEETS — 5 SQUARES 3-0237 — 200 SHEETS — 5 SQUARES 3-0137 — 200 SHEETS — FILLER</p> <p style="font-size: x-small;">COMET</p>	<p>Alex Burg</p>	<p>Tech Report 1</p>	<p>2nd Floor Composite Deck</p> <p style="text-align: right; font-size: small;">Beam Girder Deck</p>	<p>2/4</p>
<p>Try W14x26</p> <p style="text-align: right;">$M_u = 252 \text{ k} > 242 \text{ k}$ $V_u = 106 \text{ k} > 86.2 \text{ k}$</p> <p style="text-align: right;">$\Sigma Q_u = 279 \text{ k}$</p>				
<p>$b_{eff} = \frac{26.33 \times 12}{4} = 78.99 \text{ in} \leftarrow \text{Controls}$ $b_{eff} = 79 \text{ in}$</p> <p>$\min 10.72 \times 12 = 128.64$</p>				
<p>$a = \frac{\Sigma Q_u}{0.85 f_c b_{eff}} = \frac{279}{0.85(4)(79)} = 1.038 > 1 \therefore \text{NG}$</p>				
<p>Try W14x30 $I = 291 \text{ in}^4$</p> <p style="text-align: right;">$M_u = 273 \text{ k} > 242 \text{ k}$ $V_u \checkmark$</p> <p style="text-align: right;">$\Sigma Q_u = 242 \text{ k}$</p>				
<p>$a = \frac{273}{0.85(4)(79)} = 0.92 < 1 \therefore \text{OK}$</p>				
<p>$I_{LL} = 572 \rightarrow \text{Table 3-20}$</p>				
<p>$\Delta_{LL} = \frac{1/360}{360} = \frac{26.3 \times 12}{360} = 0.88$</p>				
<p>$\Delta_{LL} = 5 \cdot W_{LL} L^4 / (384(E)I_{LL})$ $W_{LL} = 100 \times 10.9 = 1090 \approx 1.1 \text{ k}$</p> <p>$= \frac{5(1.1)(26.3)^4 \times 1728}{384(29000)572}$</p> <p>$= 0.72 < 0.88 \therefore \text{OK}$</p>				
<p>$\Delta_{reg} = \frac{1/240}{240} = \frac{26.3 \times 12}{240} = 1.32$</p>				
<p>$I_{req} = 5 W_{LL} L^4 / (384 E \Delta)$ $W_{LL} = 39 \text{ psf} \times 10.72 = 418.08 \text{ psf} \approx 0.42 \text{ k}$</p> <p>$= \frac{5(0.42)(26.3)^4 \times 1728}{384(29000)(1.32)}$</p> <p>$= 118.1 < 291 \therefore \text{No Camber}$</p>				

Deck
Beam
Girder

3/4

Alex Burg Tech. Report 1 2nd Floor Composite

Try W16x26

$\phi M_n = 270$ $W = 12(15+20+39+26) + 1.6(100)$
 $\Sigma Q_n = 242$ $W_s = 280 \times 10.72$
 $s_L = 3.0 \text{ K/lf}$

$base = \frac{(26.33 \times 12)}{4} = 79^{\circ}$ ← controls $M_u = \frac{3(26.3)^3}{8} = 259 < 270 \checkmark$
 $min 10.72 \times 12 = 128.6^{\circ}$

$a = \frac{\Sigma Q_n}{0.85(F_c)(base)} = \frac{242}{0.85(4)79} = 0.9 < 1^{\circ} \therefore OK$ Studs
 $\frac{242}{17.2} \times 2 = 28 \text{ Studs}$

$I_b = 619 \text{ in}^4 \rightarrow \text{table 3-20}$ $I = 301 \text{ in}^4$

Live Load Deflection Check

$\Delta_{LL} = \frac{1}{360} = \frac{26.3 \times 12}{360} = 0.88^{\circ}$
 $\Delta_{LL} = \frac{5 \times W_{LL} l^4}{384(E)(I_{LD})} = \frac{5(1.1)(26.3)^4 \times 1728}{384(29000)619}$ $W_{LL} = 100 \times 10.9 = 1090 \approx 1.1 \text{ K}$
 $= 0.66 < 0.88 \therefore OK$

Deflection Due to Wet Concrete Check

$\Delta_{wet} = \frac{1}{240} = \frac{26.3 \times 12}{240} = 1.32^{\circ}$ $W_{wet} = 39 \times 10.72 = 418.08 \approx 0.42 \text{ K}$

$I_{req} = \frac{5 W_{wet} l^4}{384(E)\Delta} = \frac{5(0.42)(26.3)^4 \times 1728}{384(29000)(1.32)} = 118.1 < 301 \text{ in}^4 \therefore \text{No Camber}$

Girder

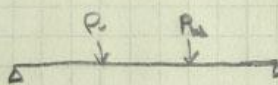

$P_u = 3 \text{ K/lf} \times 26.3/2 = 39.5 \text{ K}$ $Q_n = 21.2$
 $V_u = 39.5 \text{ K}$ $V_c = 2.5^{\circ}$
 $M_u = \frac{P_u l}{3} = \frac{39.5(32.167)}{3} = 423.5 \text{ K}$ $a = 1^{\circ}$

<p>9-0235 — 50 SHEETS — 5 SQUARES 9-0236 — 100 SHEETS — 5 SQUARES 9-0237 — 200 SHEETS — 5 SQUARES 9-0137 — 200 SHEETS — FILLER</p> <p>COMET</p>	<p>Alex Burg</p>	<p>Tech. Report 1</p>	<p>2nd Floor Composite Deck Beam Girder</p>	<p>4/4</p>
		<p><u>Try W18x40</u></p> <p>$\phi M_n = 459 \text{ k}$ $\Sigma Q_n = 353 \text{ k}$</p>	<p>$M_u = 423.5 + \frac{1.2(0.04)(32.167)^2}{8}$ $= 429.7 < 459 \checkmark$</p>	
		<p>$bedd = \frac{(32.167 \times 12)}{4} = 96.5'' \leftarrow \text{controls}$ $\text{min } 26.3 \times 12 = 315.6''$</p>		
		<p>$a = \frac{353}{0.45(4)96.5} = 1.08'' > 1'' \text{ NG}$</p>		
		<p><u>Try W21x62</u></p> <p>$\phi M_n = 759$ $\Sigma Q_n = 318$</p>	<p>$M_u = 423.5 + \frac{1.2(0.062)(32.167)^2}{8}$ $= 433.1 < 759$</p>	
		<p>$a = \frac{318}{0.45(4)(96.5)} = 0.97'' > 1'' \therefore \text{OK}$</p>		
		<p><u>Studs</u></p> <p>$\frac{353}{21.2} \times 2 = 34 \text{ Studs}$</p>		
		<p>$I_{16} = 2070 \text{ in}^4 \quad I = 1330 \text{ in}^4$ $\hookrightarrow (3-20)$</p>		
		<p><u>Live Load Deflection Check</u></p> <p>$\Delta_{LL} = \frac{1}{360} = \frac{(32.167 \times 12)}{360} = 1.1''$</p> <p>$\Delta_{LL} = \frac{P_{LL} L^3}{28 E I_{LL}} =$ $= \frac{22.6 \times (32.167)^3 \times 1728}{28 \times 29000 \times 2070} = 0.77'' < 1.1'' \text{ OK}$</p>	<p>$P_{LL} = \frac{1.6(100)}{2} \times \frac{26.3}{10.72} \times 10.72$ $= 22.6''$</p>	
		<p><u>Check Deflection Due to Wet Concrete</u></p> <p>$\Delta_{wet} = \frac{1}{240} = \frac{(32.167 \times 12)}{240} = 1.61''$</p> <p>$I_{req} = \frac{(35 W_{con} L^4 + 96 P_{con} L^3)}{2688 (29,000) (1.61)} =$ $= \frac{(35(0.51)(32.3)^4 + 96(5.5)(32.3)^3) \times 1728}{2688 (29,000) (1.61)}$ $= 245 < 1330 \therefore \text{OK}$</p>	<p>$W_{con} = 39 \left(\frac{26.3^3}{2} \right) = 0.51$ $P_{con} = (42) \left(\frac{26.3^3}{2} \right) = 5.5$</p>	

Appendix 4: Flat Plate with Drop Panels

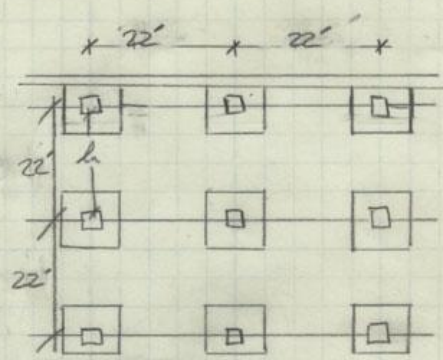
<p>Alex Burg</p> <p>Tech Report 2</p> <p>Flat Plate w Drop Panels</p> <p>1/2</p>	<p><u>Slab Thickness</u></p> <p>$t_{min} = \frac{L_n}{36}$ Assume a 12" column $\geq \frac{4}{in}$</p> <p>$= \frac{22 \times 12}{36}$</p> <p>$= 7.33 \approx 7.5"$</p>  <p><u>Interior Panel</u> (Designed from pg 10-32 in the ACI Manual)</p> <p>$L_n = 80 \text{ psf}$ $W_u = 1.2(20 + 15) + 1.6(80) = 170 \text{ psf} = 200 \text{ psf}$ (use for factored superimposed load in the ACI Design Manual)</p> <p>$SD_n = 20 \text{ psf}$</p> <p>MEP load = 15 psf</p> <p>Square Column Size = 17 in</p> <p><u>Reinforcement</u></p> <p>Column Strip: $\frac{\text{Top}}{(13) \#5}$ $\frac{\text{Bottom}}{(15) \#4}$</p> <p>Middle Strip: $\frac{\text{Top}}{(11) \#4}$ $\frac{\text{Bottom}}{(10) \#4}$</p> <p>Total Reinforcement Weight/Panel = 223 psf</p> <p><u>Exterior Panel</u></p> <p>Square Drop Panel \rightarrow Depth = 4.25" + Width = 733" \leftarrow All panels</p> <p>Square Column Size \rightarrow 15"</p>
--	---

<p>Alex Burg</p> <p>3-0235 — 50 SHEETS — 5 SQUARES 3-0236 — 100 SHEETS — 5 SQUARES 3-0237 — 200 SHEETS — 5 SQUARES 3-0137 — 200 SHEETS — FILLER</p> <p>COMET</p>	<p>Tech Report 2</p>	<p>Flat Plate w Drop Panels</p>	<p>2/2</p>
---	----------------------	---------------------------------	------------

Reinforcement

Column Strip: Top Ext Bottom Top Int.
 (12) #4 (23) #4 (14) #5

Middle Strip: Bottom Top Int.
 (10) #5 (2) #4

Total Reinforced Weight = 2.53 psf

Moment Diagram

RS MEANS Assemblies Cost Estimate

Page 450 → Superimposed Load = 125 psf
 Bay size = 22' x 22'

Cost per sq. ft. = 125.85

Deflection

$$\Delta = \left(\frac{L}{40}\right) \left(\frac{L}{360}\right)$$

$$= \left(\frac{16(80)}{170}\right) \left(\frac{2075(12)}{360}\right)$$

$$= 0.52$$

Appendix 5: Solid One Way Slab

Alex Burg Tech. Report 2 Solid One Way Slab w/ Beams 1/3

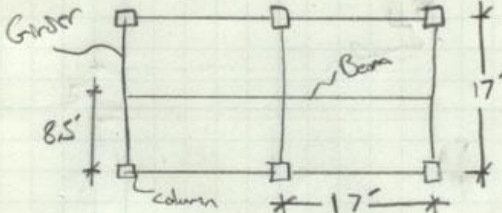

Minimum Thickness for Slab
 Table 9.5(a), ACI 318-08
 Solid One-Way-Slab
 Both ends continuous

$$t_{min} = l/28 \Rightarrow \frac{8.50' \times 12}{28} = 3.65 \approx 4''$$

$L_1 = 8'-6''$
 Slab thickness = 4"
 $W_u = 1.2(20 + 15) + 1.6(80) = 170 \text{ psf}$

Reinforcement Design from Ch. 7 in the CRSI
 When $\rightarrow \rho \approx 0.0050$ Grade 60 Bars
 $f_c = 4 \text{ ksi}$

an 8.5" span @ 4" thick slab can bear 224 psf > 170 psf \therefore

Bottom Bars: #4 @ 12" spacing
Top Bars: #3 @ 12" spacing
Temperature / Shrinkage Bars: #3 @ 11" spacing

Area of Steel: 0.20 in²/ft
Slab Weight: 50 psf
Steel Weight: 1.25 psf

Crack Control
 Max Spacing, $s = 12(40,000/f_s)$
 $s = 12(40,000/40,000) = 12'' \therefore$ ok since the spacing is not greater than 12"

Alex Burg

Tech. Report 2

Solid One Way Slab to Beam 2B

Deflection

$$\text{deflection } \Delta = \left(\frac{L}{w_u}\right) \left(\frac{L}{360}\right)$$

$$\Delta = \left(\frac{1.96(8.5)}{170}\right) \left(\frac{8.5 \times 12}{360}\right)$$

$$\Delta = 0.21''$$

RS Means Assemblies Cost Estimate

P_g 450 → Superimposed DL = 125 psf
 Bay Size = 17' x 17'

RS Means does not have a 17' x 17' bay
 so I multiplied the 15' x 15' bay cost
 by the ratio of 17/15 giving
 a cost per square foot of \$17.71

Beam Design

$$t = L/21 \rightarrow \frac{17 \times 12}{21} = 9.71 \Rightarrow 10.0'' = \text{use } 12'' \text{ depth to go into CRSI Design Handbook}$$

Slab weight @ 4" = 50 psf x 1.2 = 60

$$w_u = (70 + 60) \times 8.5 = 1955 \text{ lb/ft} = 1.96 \text{ K/ft}$$

@ b = 10" $1.96 \text{ K} < 1.97 \text{ K} \therefore \text{OK}$

Bottom Reinforcement: 2 #6

Top Reinforcement: 2 #7

Stirrups: 183B → (18) #3 @ 2', 17 @ 4" Each End

Design Moment strength Capacity: $+M_n = 35 \text{ K}$
 For the Given Rectangular Section $-M_n = 45 \text{ K}$

Steel weight = .136 K

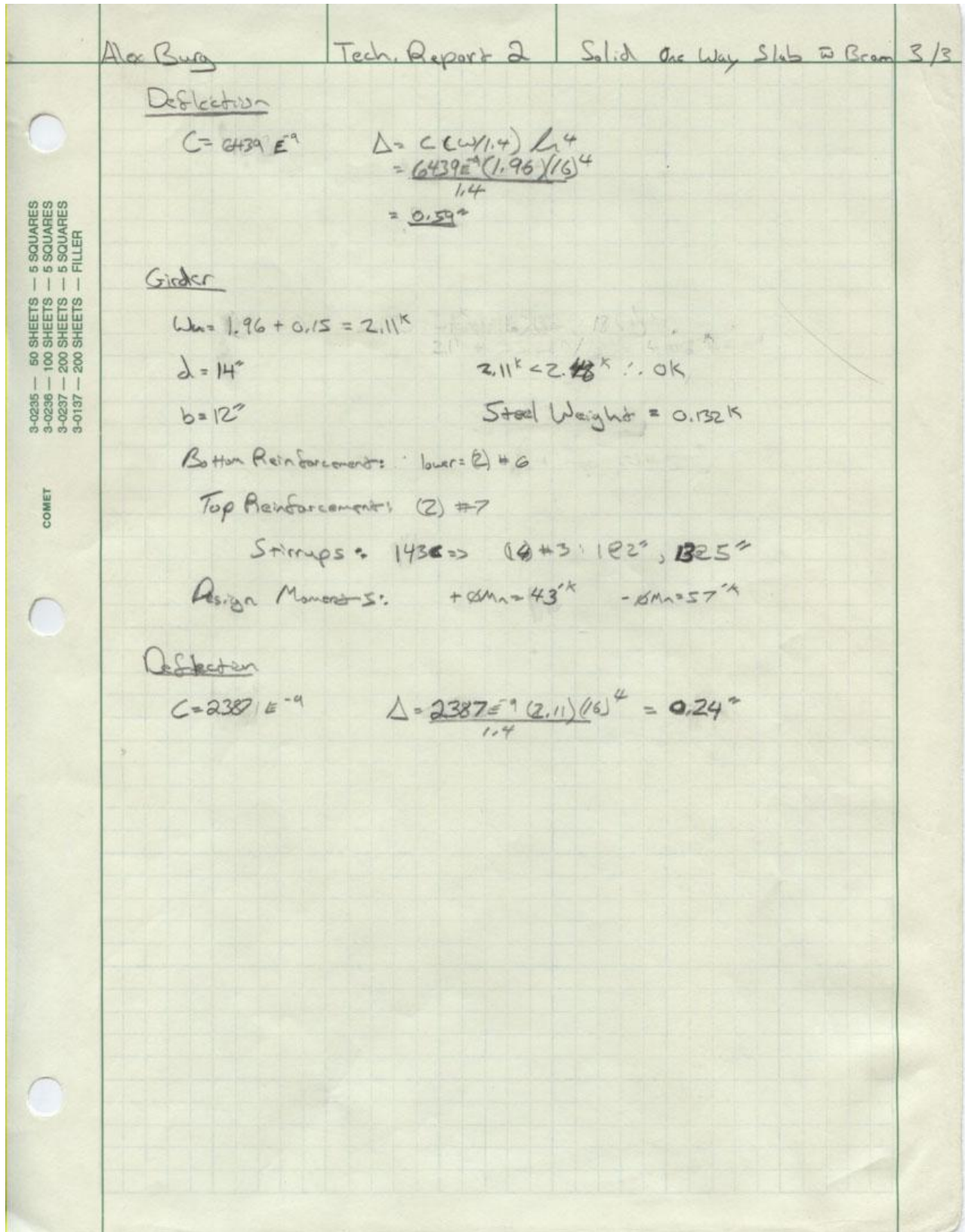

Appendix 6: Hollow Core Concrete

Alex Burg Tech Report 2 Hollow Core Concrete / Steel Girder 1/2

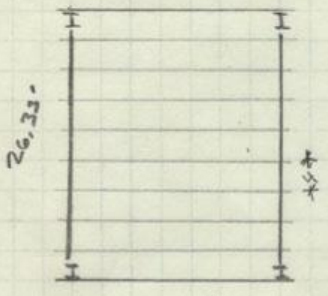

$L = 80 \text{ psf}$
 Superimposed $D_L = 20 \text{ psf}$
 MEP = 15 psf
 $D_2 = 10 \text{ psf}$ (Framing)
 Hollow Core Concrete Selected by Nitterhouse
 • 2 hour fire Rating
 Precast We. = 48.75 psf
 Topping We. = 25 psf
 Total Weight: $152 + 1.2(48.75 + 25) = 240.5 \text{ psf}$
 Superimpose Load:
 $1.2(20) + 1.6(80) = 152 \text{ psf}$
 Use (6) - $\frac{1}{2}'' \phi$ @ 18" span
 $269 > 240.5 \therefore \text{OK}$

Flexural Check

$$M_u = \frac{240.5(4)(18)}{8} = 39 \text{ K-ft} \approx \frac{467.5 \text{ k-in}}{92.6 \text{ K-ft}} \therefore \text{OK}$$

$$P_{s,d} = 0.16(270)(0.153) = 24.8 \text{ \% strand}$$

$$f_c = \frac{467.5}{799.1} - \frac{(24.8)(4)}{253.1} + \frac{24.8(4)(2.65)}{799}$$

$$= -0.65 \text{ ksi} \approx 650 \text{ psi} < 0.45 f_c = 0.45(6006) = 2702 \therefore \text{OK}$$

$$f_{s,t} = \frac{467.5}{370} - \frac{24.8(4)}{253} - \frac{24.8(4)(2.65)}{370}$$

$$= 0.16 \approx 160 \text{ psi} < 10 \sqrt{f_c} = 775 \therefore \text{OK}$$

Use: 6" Hollow Core with 2" topping + (6) $\frac{1}{2}'' \phi$ strand
 But check Deflection

Alex Burg	Tech Report 2	Hollow Core Concrete/Steel Girder	2/2
-----------	---------------	-----------------------------------	-----

Deflection Check:

$$\Delta_{LL} = \frac{5 w_u l^4}{384 E I} = \frac{5 (0.02) (4)(18)^4 (1728)}{384 (4417) (1510)} \quad E = 57,000 \text{ ksi} \quad \sqrt{E_c} = 57,000 \sqrt{16,000} = 4,428 \text{ ksi} \approx 4,428 \text{ ksi}$$

$$= 0.11" < \Delta_{LL, max} = \frac{l}{360} = \frac{26.33 \times 12}{360} = 0.88 \therefore \text{OK}$$

$$\Delta_{TL} = \frac{5 (0.24) (4)(18)^4 (1728)}{384 (4417) (1510)}$$

$$= 0.34" < \Delta_{TL, max} = \frac{l}{240} = 1.32 \therefore \text{OK}$$

Beam Size

$$w_u = 24.5 (18) = 432 \text{ plf} \approx 4.3 \text{ KLF}$$

$$I_{req'd} = \frac{5 (1.6)(18)^2 (26.33)^4 (1728)}{384 (29,000) ((26.33 \times 12) / 240)} = 978.9 \text{ in}^4$$

$$I_{req'd} = \frac{5 (4.3) (26.33)^4 (1728)}{384 (29,000) ((26.33 \times 12) / 240)} = 1218 \text{ in}^4$$

$$M_u = \frac{w_u l^2}{8} = \frac{4.3 (26.33)^2}{8} = 372.6 \text{ K-ft}$$

$$V_u = \frac{4.3 l}{2} = \frac{4.3 (26.33)}{2} = 56.6 \text{ K}$$

Try w 24x55 $\rightarrow I = 1350 \text{ in}^4 > 1218 \text{ in}^4 \checkmark$ Use a W24x55

$d = 23.6" \quad \phi M_n = 503 \text{ K-ft} > 372.6 \text{ K-ft} \checkmark$

$\phi V_n = 252 \text{ K} > 56.6 \text{ K} \checkmark$

$$\Delta_s \rightarrow I = 1350 = 0.63" < 0.87$$

$$\Delta = \Delta_s + \Delta_c = 0.63 + 0.11 = 0.74 < 0.87 \checkmark$$

RS Means Assembly Cost Estimate

Page 450 \rightarrow Superimposed load = 125 psf
 Bay Size = 26'x18' \rightarrow No such Bay Size in RS Means

Cost Per Square Foot
\$24.10

DESIGN DATA

1. Precast Strength @ 28 days = 6000 PSI
2. Precast Strength @ release = 3500 PSI
3. Precast Density = 150 PCF
4. Strand = 1/2"Ø 270K Lo-Relaxation.
5. Strand Height = 1.75 in.
6. Ultimate moment capacity (when fully developed)..
 - 4-1/2"Ø, 270K = 67.4 k-ft at 60% jacking force
 - 6-1/2"Ø, 270K = 92.6 k-ft at 60% jacking force
 - 7-1/2"Ø, 270K = 95.3 k-ft at 60% jacking force
7. Maximum bottom tensile stress is $10\sqrt{f_c} = 775$ PSI
8. All superimposed load is treated as live load in the strength analysis of flexure and shear.
9. Flexural strength capacity is based on stress/strain strand relationships.
10. Deflection limits were not considered when determining allowable loads in this table.
11. Topping Strength @ 28 days = 3000 PSI. Topping Weight = 25 PSF.
12. These tables are based upon the topping having a uniform 2" thickness over the entire span. A lesser thickness might occur if camber is taken into account during design, thus reducing the load capacity.
13. Load values to the left of the solid line are controlled by ultimate shear strength.
14. Load values to the right are controlled by ultimate flexural strength or allowable service stresses.
15. Load values will be different for IBC 2000 & ACI 318-99. Load tables are available upon request.
16. Camber is inherent in all prestressed hollow core slabs and is a function of the amount of eccentric prestressing force needed to carry the superimposed design loads along with a number of other variables. Because prediction of camber is based on empirical formulas it is at best an estimate, with the actual camber usually higher than calculated values.

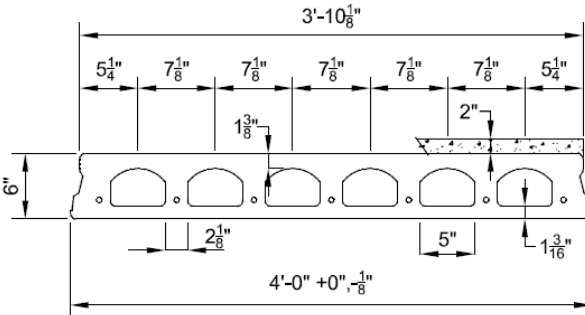

SAFE SUPERIMPOSED SERVICE LOADS		IBC 2006 & ACI 318-05 (1.2 D + 1.6 L)																		
Strand Pattern	LOAD (PSF)	SPAN (FEET)																		
		12	13	14	15	16	17	18	19	20	21	22	23	24	25	26	27	28	29	30
4 - 1/2"Ø	LOAD (PSF)	349	317	290	258	227	197	179	157	148	131	110	91	75	60	XXXXXXXXXX				
6 - 1/2"Ø	LOAD (PSF)	524	478	437	377	334	292	269	237	224	193	166	142	122	104	88	73	61	49	39
7 - 1/2"Ø	LOAD (PSF)	541	492	451	416	364	331	293	274	242	214	190	167	144	124	107	91	77	64	53

Prestressed Concrete 6"x4'-0" Hollow Core Plank

1 Hour Fire Resistance Rating With 2" Topping

PHYSICAL PROPERTIES Composite Section	
$A_c = 253 \text{ in.}^2$	Precast $b_w = 16.13 \text{ in.}$
$I_c = 1519 \text{ in.}^4$	Precast $S_{bcp} = 370 \text{ in.}^3$
$Y_{bcp} = 4.10 \text{ in.}$	Topping $S_{tct} = 551 \text{ in.}^3$
$Y_{tcp} = 1.90 \text{ in.}$	Precast $S_{tcp} = 799 \text{ in.}^3$
$Y_{tct} = 3.90 \text{ in.}$	Precast Wt. = 195 PLF
	Precast Wt. = 48.75 PSF

Appendix 7: RS Means

Table B1010-101 Comparative Costs (\$/S.F.) of Floor Systems/Type (Table Number), Bay Size, & Load

Bay Size	Cast-in-Place Concrete						Precast Concrete				Structural Steel					Wood Beams & Joists B1010-264
	1 Way BM & Slab B1010-219	2 Way BM & Slab B1010-220	Flat Slab B1010-222	Flat Plate B1010-223	Joist Slab B1010-226	Waffle Slab B1010-227	Beams & Hollow Core Slabs B1010-236	Beams & Hollow Core Slabs Topped B1010-238	Beams & Double Tees Topped B1010-239	Bar Joists on Cols. & Brg. Walls B1010-248	Bar Joists & Beams on Cols. B1010-250	Composite Beams & C.I.P. Slab B1010-252	Composite Deck & Slab, W Shapes B1010-254	Composite Beams & DK., Lt. Wt. Slab B1010-256		
Superimposed Load = 40 PSF																
15 x 15	15.28	14.43	12.85	12.34	16.15	—	—	—	—	10.25	12.14	—	—	—	13.22	
15 x 20	15.28	15.00	13.20	13.13	16.30	—	—	—	—	10.53	13.04	—	—	—	15.86	
20 x 20	15.44	15.75	13.70	13.09	16.30	17.80	21.13	23.85	—	12.08	14.86	19.95	18.90	17.30	15.24	
20 x 25	15.69	16.65	14.70	14.40	16.45	18.05	20.04	23.10	—	12.77	15.85	20.45	21.00	16.80	—	
25 x 25	15.75	17.00	15.10	14.70	16.30	18.35	21.31	24.70	—	—	—	—	—	—	—	
25 x 30	16.10	17.75	16.05	—	17.05	18.60	20.29	22.84	23.26	13.11	16.45	22.20	21.10	17.00	—	
30 x 30	17.80	19.10	16.85	—	17.50	19.45	20.68	24.48	24.55	12.99	16.50	22.20	23.15	17.30	—	
30 x 35	18.55	20.50	17.90	—	18.10	19.70	20.47	24.03	—	14.43	18.35	23.10	25.00	18.05	—	
35 x 35	19.70	21.35	18.20	—	18.25	20.50	21.52	24.48	—	14.83	18.85	24.00	25.45	18.85	—	
35 x 40	20.15	22.60	—	—	18.90	21.00	21.52	25.23	—	22.68	—	25.95	26.75	20.70	—	
40 x 40	—	—	—	—	19.40	21.65	22.39	26.21	25.09	—	—	—	—	—	—	
40 x 45	—	—	—	—	20.10	22.15	—	—	—	—	—	—	—	—	—	
40 x 50	—	—	—	—	—	—	—	—	23.37	—	—	—	—	—	—	
Superimposed Load = 75 PSF																
15 x 15	15.40	14.60	13.02	12.36	16.25	—	—	—	—	11.12	13.76	—	—	—	16.46	
15 x 20	15.84	16.20	13.73	13.65	17.00	—	—	—	—	11.88	14.95	—	—	—	19.95	
20 x 20	16.75	17.05	14.30	13.70	17.15	18.10	18.10	24.80	—	13.66	15.65	22.25	23.00	17.85	—	
20 x 25	17.15	18.50	15.50	14.70	17.25	18.40	20.04	23.60	—	13.58	17.20	23.50	23.90	18.25	—	
25 x 25	17.00	18.35	15.70	15.20	17.25	18.85	21.81	21.10	—	—	—	—	—	—	—	
25 x 30	17.20	19.20	16.85	—	17.60	19.05	20.82	24.06	23.26	13.79	17.55	25.00	25.05	18.00	—	
30 x 30	19.10	20.75	17.70	—	18.05	19.80	21.46	25.92	24.55	14.83	18.85	24.75	26.70	18.50	—	
30 x 35	19.35	21.50	18.90	—	18.35	19.70	21.55	23.89	—	16.90	21.15	26.55	28.75	19.35	—	
35 x 35	21.45	22.35	19.35	—	19.05	20.95	22.41	25.77	—	18.10	22.75	27.35	29.20	21.20	—	
35 x 40	21.75	23.40	—	—	19.65	21.65	—	—	23.26	—	—	29.20	30.70	22.20	—	
40 x 40	—	—	—	—	19.90	22.35	—	—	25.59	—	—	—	—	—	—	
40 x 45	—	—	—	—	20.30	22.85	—	—	—	—	—	—	—	—	—	
40 x 50	—	—	—	—	—	—	—	—	22.51	—	—	—	—	—	—	
Superimposed Load = 125 PSF																
15 x 15	15.63	15.30	13.40	12.61	16.50	—	—	—	—	13.07	16.30	—	—	—	24.35	
15 x 20	16.45	17.55	14.30	14.45	17.40	—	—	—	—	14.75	17.00	—	—	—	28.90	
20 x 20	17.55	17.70	15.25	14.45	17.40	18.40	—	—	—	14.60	18.20	24.85	26.65	21.55	—	
20 x 25	18.20	18.95	16.45	15.45	18.15	18.70	—	—	—	15.80	19.95	26.75	28.35	19.25	—	
25 x 25	19.70	19.95	16.60	15.85	19.00	19.30	—	—	—	—	—	—	—	—	—	
25 x 30	19.80	20.80	17.45	—	18.80	19.50	—	—	—	16.70	21.10	29.15	28.25	20.85	—	
30 x 30	20.30	21.85	18.35	—	19.05	20.05	—	—	—	18.60	23.55	29.05	31.35	21.95	—	
30 x 35	21.60	23.50	19.50	—	19.10	20.55	—	—	—	19.00	23.90	32.55	33.30	22.60	—	
35 x 35	22.80	24.40	19.85	—	19.15	21.30	—	—	—	21.15	25.10	31.60	34.55	24.80	—	
35 x 40	23.05	24.60	—	—	19.55	22.35	—	—	—	—	—	34.20	35.95	25.35	—	
40 x 40	—	—	—	—	20.75	22.70	—	—	—	—	—	—	—	—	—	
40 x 45	—	—	—	—	20.95	23.20	—	—	—	—	—	—	—	—	—	
40 x 50	—	—	—	—	—	—	—	—	—	—	—	—	—	—	—	
Superimposed Load = 200 PSF																
15 x 15	16.31	16.35	13.90	—	17.05	—	—	—	—	—	—	—	—	—	45.70	
15 x 20	17.80	18.80	14.60	—	17.90	—	—	—	—	—	—	—	—	—	40.35	
20 x 20	19.10	19.15	15.50	—	18.20	19.20	—	—	—	—	—	—	—	—	—	
20 x 25	19.65	20.65	16.95	—	19.05	19.45	—	—	—	—	—	30.50	30.00	23.95	—	
25 x 25	21.40	22.50	17.25	—	19.65	19.75	—	—	—	—	—	31.70	32.70	24.95	—	
25 x 30	21.55	22.70	18.25	—	19.85	20.85	—	—	—	—	—	33.60	34.50	25.05	—	
30 x 30	22.60	23.35	19.35	—	20.05	21.60	—	—	—	—	—	35.15	41.30	26.15	—	
30 x 35	22.85	24.80	—	—	20.50	22.35	—	—	—	—	—	38.45	39.85	26.35	—	
35 x 35	24.70	25.65	—	—	20.55	22.70	—	—	—	—	—	39.10	43.50	28.05	—	
35 x 40	24.90	26.25	—	—	20.90	24.10	—	—	—	—	—	42.35	45.20	30.10	—	
40 x 40	—	—	—	—	—	—	—	—	—	—	—	—	—	—	—	
40 x 45	—	—	—	—	—	—	—	—	—	—	—	—	—	—	—	
40 x 50	—	—	—	—	—	—	—	—	—	—	—	—	—	—	—	

450