

# INTELLIGENT POSITIONING OF MOBILE CRANES FOR STRUCTURAL STEEL ERECTION

by

Karl A. Raynar

Technical Report No. 18

© Copyright

August 1990

The logo consists of the letters 'C', 'I', and 'C' in a bold, sans-serif font, each enclosed in a small circle. These three circles are arranged horizontally and are contained within a larger, horizontally-oriented oval shape.

C I C

*COMPUTER INTEGRATED CONSTRUCTION*

Computer Integrated Construction Research Program  
Department of Architectural Engineering  
The Pennsylvania State University  
University Park, PA 16802

## ABSTRACT

The crane is the single most important equipment cost item required for erecting structural steel. This thesis uses artificial intelligence techniques to find the minimum number of crane positions necessary to erect structural steel. A method is developed for selecting the crane paths and determining the steel erection sequence.

Case studies are conducted of three steel erectors to determine the process and information requirements for planning structural steel erection. A generic single story steel framed building is developed consisting of basic structural elements. The steel erection procedures are converted into logic based rules. A control strategy is devised to analyze the various combinations of possible crane positions. The generic building, rules and control strategy are incorporated into a production rule system. The result is a Prolog computer program called PRECISE, which will find the optimal crane positions and the structural members erected from each crane position. The program is tested on three different buildings using four different cranes. The application of the PRECISE program to compare costs and schedule times is presented.

## TABLE OF CONTENTS

LIST OF FIGURES.....	xi
LIST OF TABLES.....	xiii
GLOSSARY .....	xiv
ACKNOWLEDGMENTS .....	xvi
Chapter 1. INTRODUCTION .....	1
1.1 Steel Erection.....	1
1.1.1 The Structural Steel Erection Process.....	1
1.1.2 Steel Erection Planning.....	4
1.1.3 Future Directions in Erection Planning.....	6
1.2 Problem Statement .....	8
1.3 Objectives .....	8
1.3.1 Understand the Process for Planning Structural Steel Erection and Define Information Requirements.....	9
1.3.2 Define a Generic Building and Develop Rules for Steel Erection Procedures.....	9
1.3.3 Develop a Program for Optimizing the Positioning of a Mobile Crane for Steel Erection .....	9
1.3.4 Test the Program.....	10
1.4 Methods.....	10
1.4.1 Understand the Process for Planning Structural Steel Erection and Define Information Requirements.....	10
1.4.2 Define a Generic Building and Develop Rules for Steel Erection Procedures.....	12
1.4.3 Develop the Positioning Review and Evaluation of Cranes In Steel Erection (PRECISE) Program .....	12
1.4.4 Test the PRECISE Program.....	13
1.5 Scope .....	13
1.6 Summary and Reader's Guide .....	14

<b>Chapter 2. THE STRUCTURAL STEEL PLANNING PROCESS</b>	
<b>AND INFORMATION REQUIREMENTS.....</b>	<b>15</b>
2.1 Research in Construction Planning Using Cranes .....	15
2.2 Integrated Building Process Model.....	18
2.3 Definition of Information Requirements.....	20
2.4 Questionnaire Development .....	22
2.5 Selection of Experts and Data Collection.....	23
2.6 Interview Procedure.....	24
2.7 Responses to Planning Questionnaire.....	24
2.7.1 Determine Scope and Coordinate Plans.....	25
2.7.2 Select Erection Methods .....	25
2.7.3 Estimate.....	26
2.7.4 Schedule.....	27
2.7.5 Analyze and Select the Plan .....	27
2.8 Information Requirements.....	28
2.9 Discussion .....	28
2.10 Summary.....	29
<b>Chapter 3. PLANNING TOOL DEVELOPMENT.....</b>	<b>30</b>
3.1 Objective of the Tool .....	30
3.2 Key Parameters of a Generic Building .....	31
3.3 Key Parameters for Crane .....	32
3.4 Analytical vs. Relational Approach to Crane Positioning	
Problem.....	34
3.5 Development of Rule Base.....	36
3.5.1 Generic Building Development.....	36
3.5.2 Steel Sequences and Relationships .....	38
3.5.3 Specific Rules for Erecting Steel .....	38

3.5.3.1	Divide Building Width If Required.....	40
3.5.3.2	Find Crane Location.....	40
3.5.3.3	Erect Row Frames.....	42
3.5.3.4	Erect Purlins.....	44
3.5.3.5	Resolve Boom Interferences.....	44
3.5.3.6	Find the Next Crane Position.....	47
3.6	Additional Considerations in Crane Positioning .....	47
3.6.1	Wide Crane Envelopes.....	47
3.6.2	Building Wider than Crane Operating Width .....	48
3.6.3	Boom Interferes with Previously Erected Members.....	51
3.7	Summary.....	53
Chapter 4. PRECISE PROGRAM.....		54
4.1	Artificial Intelligence Background.....	54
4.2	Strategy for Crane Positioning Using Artificial Intelligence Techniques.....	55
4.3	Methodology.....	57
4.4	Production Rules .....	58
4.5	Selection of Prolog.....	60
4.6	Prolog Description.....	61
4.7	PRECISE Program Description .....	66
4.7.1	Check Productivity.....	67
4.7.2	Input Crane and Building Data.....	73
4.7.3	Develop Generic Building.....	73
4.7.4	Determine Parameters.....	74
4.7.5	Determine Alternate Pass Combinations.....	75
4.7.6	Generate Alternate Erection Plans.....	76
4.7.7	Find Crane Positions.....	77
4.7.8	Make Erection List .....	78
4.7.9	Check Last Row .....	79
4.7.10	Check Boom Interference.....	79

4.7.11 Crane Sweeps .....	79
4.8 Example Building Solution .....	80
4.9 Summary .....	89
Chapter 5. PROGRAM TESTING .....	90
5.1 Building Descriptions .....	90
5.2 Crane Descriptions .....	91
5.3 Cost Analysis Basis .....	92
5.4 Assumptions Used in Cost Analysis .....	93
5.5 Results of Cost Analysis .....	94
5.6 Summary .....	97
Chapter 6. CONCLUSIONS .....	98
6.1 Contributions .....	98
6.2 Benefits of Using PRECISE .....	99
6.3 Problem Areas .....	101
6.4 Areas for Further Program Development .....	101
6.5 Other Applications .....	103
6.6 Summary .....	105
ANNOTATED BIBLIOGRAPHY .....	106
APPENDIX A. DERRICKS AND CRANES USED IN STEEL ERECTION .....	111
A.1 Introduction .....	111
A.2 Derricks .....	111

A.2.1	Guy Derrick.....	111
A.2.2	Chicago Boom.....	113
A.2.3	Stiffleg Derrick.....	114
A.3	Tower Cranes.....	114
A.3.1	Fixed Tower Cranes.....	114
A.3.2	Climbing Tower Cranes.....	117
A.3.3	Traveling Tower Cranes.....	119
A.4	Mobile Cranes.....	119
A.4.1	Undercarriages.....	119
A.4.2	Booms.....	120
A.5	Crane Load Ratings.....	124
APPENDIX B. INTERVIEW PACKAGE.....		128
B.1	Outline of Interview Procedure.....	128
B.2	Questionnaire for Planning Steel Erection.....	130
B.2.1	General.....	131
B.2.2	Determine Scope and Coordinate Plans.....	131
B.2.3	Select Erection Methods.....	131
B.2.4	Estimate the Work.....	133
B.2.5	Schedule the Work.....	133
B.2.6	Analyze and Select the Plan.....	133
B.3	Information Checklist.....	134
APPENDIX C COMPANY A - CASE STUDY - PLANNING STEEL ERECTION USING A MOBILE CRANE.....		137
C.1	General.....	137
C.2	Determine Scope and Coordinate Plans (Preplanning).....	137
C.3	Select Erection Methods.....	138
C.4	Planning Information.....	139

C.5	Estimate.....	139
C.6	Schedule.....	140
C.7	Analyze and Select the Erection Plan.....	140
C.8	Erection Procedure .....	141

#### APPENDIX D COMPANY B - CASE STUDY - PLANNING STEEL

	ERECTION USING A MOBILE CRANE.....	143
D.1	General.....	143
D.2	Determine Scope and Coordinate Plans (Preplanning).....	143
D.3	Select Erection Methods.....	144
D.4	Planning Information.....	146
D.5	Estimate.....	147
D.6	Schedule.....	147
D.7	Analyze and Select the Plan.....	148
D.8	Erection Procedure .....	148

#### APPENDIX E. COMPANY C - CASE STUDY - PLANNING STEEL

	ERECTION USING A MOBILE CRANE.....	149
E.1	General.....	149
E.2	Determine Scope and Coordinate Plans.....	150
E.3	Select Erection Methods.....	151
E.4	Planning Information.....	152
E.5	Estimate.....	154
E.6	Schedule.....	154
E.7	Analyze and Select the Plan.....	155
E.8	Erection Procedure .....	155



APPENDIX F. PRECISE PROGRAM OUTPUT.....158

## LIST OF FIGURES

1.1	Research Methodology for Developing PRECISE Program.....	11
2.1	Construct Facility Model.....	19
2.2	Develop the Construction Plan.....	21
3.1	Generic Building.....	33
3.2	Graphic Representation of Analytical Approach to Locating Crane.....	35
3.3	Determinining the Crane Location for a Given Passwidth.....	41
3.4	Crane Erection Envelope.....	43
3.5	Purlin Erection Sequence.....	45
3.6	Effect of Reducing Crane Envelope Width.....	49
3.7	Alternate Pass Width Combinations.....	50
3.8	Determine Boom Interference Angle.....	52
4.1	Sample Prolog Program for Steel Connections.....	62
4.2	Matching and Backtracking Process for Example Prolog Program for Steel Connections.....	65
4.3	Check Productivity Program Module.....	68
4.4	Initialize Pass Combinations Program Module.....	69
4.5	Evaluate Best Plan Program Module.....	70
4.6	Crane Sweeps Program Module.....	71
4.7	Example Building.....	72
4.8	Find Crane Position for [2,3] Pass Combination.....	83
4.9	Representative Crane Envelope for [2,3] Bay Pass Combination.....	84
5.1	Crane Moves as a Function of Crane Radius for 3 Buildings.....	96

A.1	Guy Derrick.....	112
A.2	Stiffleg Derrick.....	115
A.3	Tower Crane.....	116
A.4	Climbing Tower Crane .....	118
A.5	Truck Crane .....	121
A.6	Load Rating Table for P&H 28 Ton Hydraulic Crane.....	122
A.7	Tipping Moment for Mobile Cranes.....	125
A.8	Mobile Crane Areas of Operation.....	127
B.1	Diagram for Develop the Erection Plan.....	129

**LIST OF TABLES**

3.1	Sources of Procedures.....	39
4.1	Summary of Crane Locations, Crane Envelopes and Members Erected.....	88
5.1	Test Building Data .....	90
5.2	Crane Cost Analysis.....	95

## GLOSSARY

**alternate pass number (APN)**- an index used for each of the possible crane pass combinations

**assert** - the process of adding factual information to a Prolog dynamic database as new information is ascertained.

**bay** - the area enclosed by four adjacent building columns to form a rectangle. This term is sometimes used interchangeably with bay spacing when referring to one dimension or direction.

**bay spacing** - the distance between two adjacent columns.

**beams** - structural elements which connect to columns and support purlins running across the building.

**columns** - vertical structural elements which support beams and purlins.

**constructability**- the review of the construction drawings by the construction manager to determine the most economical design from a construction point of view.

**crane envelope** - see crane erection envelope.

**crane erection envelope** - a rectangle inscribed within the semicircle whose radius is the crane load radius. The width of the rectangle is equal to the crane pass width and the depth is reduced by the crane setback (Refer to Figure 3.4).

**divisioning** - the subdivision of the structural steel into areas of approximately equal tonnages. This divisioning is coordinated between the fabricator and erector and is based on site conditions, schedules, transportation requirements.

**knowledge representation** - the study of the way in which information can be stored in the human brain and analogous ways in which bodies of knowledge can be stored in data structures for the purposes of symbolic computation(Jackson,1986).

**operating width** - the maximum width which the crane can reach across, expressed as an integer number of bay spacings.

**pass** - the straight line travel path of the crane as it erects steel beginning at one end of the building.

**pass width combination** - the combination of pass widths which are required by the crane to provide coverage for the entire building. This combination is a list of integers and is noted as [PWList] in the program.

**pass width** - the width of a crane pass expressed as an integer number of bays.

**productivity** - the total number of structural members that can be erected from a single crane position.

**purlins** - structural elements which connect to beams and run along the length of the building supporting the roof.

**recursive rule** - a rule is a rule that calls itself. It must have a terminating condition to prevent an infinite loop from occurring.

**tier** - a level of structural steel corresponding to the length of a fabricated column. A tier generally consists of two floors of beams interconnected between columns.

## ACKNOWLEDGMENTS

I would like to express my appreciation to Dr. Victor Sanvido for providing me with guidance and creative ideas in my research efforts. I thank him for providing the facility and atmosphere which have been conducive to scholarly research in the CIC Lab. His energy has provided with inspiration during times when I most needed it.

I wish to express my gratitude to the members of my thesis committee, Drs. Gary Smith and Soundar Kumara, for their time and comments reviewing my thesis. I thank the faculty of the Architectural Engineering and Civil Engineering Departments for their support in providing me with ideas and materials which were used to develop my thesis. I also thank the people at the companies I interviewed and visited for participating in this project.

I wish to thank my friends in the CIC lab for their support and constructive criticism. I thank Matt Syal for his friendship and encouragement.

Finally, I would like to thank my wife, Paula; my son, John; and my daughter, Laurel; for their patience during the past months while I have been involved in this work. Their understanding and patience have been pushed to the limits.

## **CHAPTER 1**

### **INTRODUCTION**

This thesis develops a method to select the paths and determine the erection sequence to give the minimum number of setup locations required for a mobile crane to erect structural steel for a single story steel framed building. An example will be provided of how this information can be used as a basis for developing comparative data to aid a steel erector in selecting the most appropriate crane for a project.

#### **1.1 Steel Erection**

This section provides background on the elements of the steel erection process with emphasis on planning and planning information.

##### **1.1.1 The Structural Steel Erection Process**

To understand the structural steel erection process, a literature search was conducted on structural steel erection methods and the use of cranes in construction. This search found one journal publication on steel erection methods and five articles on cranes in construction. A summary of the research on cranes is discussed in Chapter 2. Several construction texts include information on steel erection and cranes, which are summarized in the following description. This information was also supplemented by interviews with steel erectors and site visits.



Structural steel erection is one of the most critical phases in the process of constructing a building, because mechanical, electrical, and architectural work cannot begin in earnest until the steel is in place. For this research, structural steel construction is broken down into three major phases (1) advance planning, (2) fabrication, and (3) erection (Nunnally,1980).

In the **advance planning** phase the fabricator and erector work together to determine the divisioning<sup>1</sup> of the steel and the maximum sizes for the structural members. The size and sequences of steel shipments are agreed upon. At this time, the erector determines the equipment to be utilized in erecting the steel based on; the type of structure being erected, the maximum size of the members which will be erected, and the anticipated site conditions (Nunnally,1980)

Equipment selection for erecting the structural steel is an essential factor in the erection methods selection process and is the essence of this thesis. The major piece of equipment is the crane, which sets the steel in place (Rapp,1980). If the crane is undersized, there may be too much time lost in moving and setting up the crane. Also, certain pieces may exceed the crane's capacity, causing unsafe working conditions and/or schedule delays. This may require the contractor to rent special equipment to complete the project and overrun cost estimates. Likewise, if the crane is oversized, equipment costs will be unnecessarily high and affect the contractor's profits.

---

<sup>1</sup> A glossary of key terms is provided (p. xiv). These words are underlined and organized in alphabetical order.

In the **fabrication phase** the steel is prepared in a shop for field assembly. The fabricator prepares detail drawings, anchor bolt location drawings, and erection drawings from the structural steel design drawings (AISC, 1983). The detail drawings (also known as shop drawings) indicate how each column, beam or girder will be made. These shop drawings identify each structural member, provide exact dimensions of each component, and detail the plates, angles, and tees which are used in making connections between members. The anchor bolt location drawings detail the anchor bolts which hold the column baseplates in place. The erection drawings provide the erector information on the location of each of the structural members and special instructions on erection sequences.

From the detail drawings, the fabricator makes templates, cuts the steel to the proper lengths, and machines the ends of the steel as required. Holes for connecting bolts are punched or drilled in the steel with the aid of templates. Stiffener plates may be welded onto the members. Finally, connection plates, angles, or tees are welded or bolted to the members to complete the assembly.

After the steel is delivered to the project the **erection phase** begins by sorting or "shaking out" the steel members in the order in which they will be erected. The steel is erected according to the erection drawings, beginning at one of the corners with an endwall of the building. Using the anchor bolt location drawings, columns for the first tier of steel are set on anchor bolts, starting from a position furthest from the crane. Rows of columns are set working back toward the crane.

Interconnecting beams are then installed between columns using only a minimum number of erection bolts in each connection. The steel is

Interconnecting beams are then installed between columns using only a minimum number of erection bolts in each connection. The steel is plumbed and aligned by using cables and turnbuckles which run diagonally between columns in a vertical plane. Diagonal bracing members are installed, and work is completed by installing the final connection bolts which are torqued to a specified value. Any connections requiring welding are made at this time.

For multistory buildings, erection continues by placing the columns for the second tier on top of columns for the first tier. The same sequence is followed for installing beams, plumbing and aligning, bracing and making final connections as was done in the first tier. This process is repeated until the structure is complete.

A study has been done on the breakdown of manhours required for erecting structural steel. The study found that 70% of the time was required for placing steel and installing bolts, 25% of the time was required for plumbing and alignment, and that 5% of the time was required for tightening of bolts (Thomas, Sanvido, and Saunders.,1988). From this study, it can be seen that placing the steel is the major component of steel erection and that any effort to improve this area will have the greatest impact on the erection process.

### **1.1.2 Steel Erection Planning**

It is this author's observation that steel erection planning has been intuitively done by project managers based on previous experiences. In some cases this may be supported by estimators using historical data to

evaluate equipment requirements and planners using quantities and crew sizes to develop schedules. Estimators compare aggregate data from previous projects when evaluating equipment requirements. Planners subdivide the project into areas and try to determine durations based on quantities and crew productivity, which does not accurately account for equipment productivity. What is needed is a tool which will give the estimator and scheduler accurate equipment productivity information to support the project manager in making rational decisions when selecting equipment and preparing bids.

Proper preplanning of steel erection requires that crane positions and loads be analyzed to develop a safe and economical erection scheme (Rapp, 1980). Maximum loads must be determined and a crane capable of setting these loads must be selected. Contract documents, drawings, specifications, and anticipated site conditions must be reviewed for information which relates to the erection process. The erector must work with the fabricator to determine the maximum size and weights of members which will be shipped and erected. Decisions must be made on matters such as the maximum column length, the amount of preassembly for trusses, and girder lengths.

Determining the proper equipment to be used will depend on required steel erection rate and equipment available. The speed of the crane in erecting the steel must be matched with the job schedule and the delivery schedule. Lighter capacity cranes with higher lift speeds may be required. As load ratings increase, the number of parts of rope between the load and lead block must increase to obtain greater mechanical advantage for the winch. This results in slower lift speeds. If the equipment is not

owned, a financial decision must be made as whether or not to lease or rent (Rapp,1980). [Refer to Appendix A for a discussion of the various types of cranes used in steel erection.]

Factors which affect the erection scheme are type, size, height, and shape of the structure to be erected. The time required for setting up a stationary tower crane must be weighed against the time lost in jumping a derrick from floor to floor. A long narrow building may be better serviced by a mobile crane which can set up in more than one position easily. When moving a mobile crane from position to position timber support mats must be provided under the outriggers if ground conditions are unstable. Local regulations regarding traffic control may affect the decisions regarding locating the crane and the speed of unloading (Wijusundera and Harris, 1985).

A site visit should be made just prior to mobilization by the erection contractor to confirm that conditions assumed during preplanning have not changed. Foundation work, excavations, the location of access roads, temporary office and storage facilities may affect the planned erection scheme. Site conditions also include ground conditions which may affect the stability of the crane.

The selection of construction equipment has been based on uncertain and intuitive knowledge permitting the application of only broad rules of thumb (Wijusundera and Harris, 1987). It is this author's opinion that planners make decisions based on previous experience with similar projects in a manner similar to the way Romans built bridges -- "If it worked on the previous project it can be modified slightly and made to work again on a

slightly larger project." Clearly, a formal method of analyzing equipment for efficiency and cost effectiveness is needed.

### **1.1.3 Future Directions in Erection Planning**

Data for planning has traditionally been generated during the construction phase by performing analysis of working drawings, rather than earlier in the project, during the design phase, as the drawings are developed. The options available to the constructor in selecting construction methods are limited at this point in time because the design is fixed.

The linkage of design and construction information will be an important concept in the future (Ibbs,1986). Computer Aided Design (CAD), where drawings are represented as electronic media, can be the design-construction link. CAD has the capability of allowing the designer to modify designs rapidly. It also permits the constructor to extract information from the drawings quickly without manual takeoffs. For example, the constructor may want to know how many columns are more than two tons and where they are located. This information can be readily extracted from CAD drawings. The flexibility in data extraction by the constructor and the ability to rapidly modify designs by the designer will improve the project delivery process. The application of CAD to construction should prove to be a vital tool to the construction manager of the future (Cleveland,1987).

With CAD as the design construction link, artificial intelligence can be applied to construction planning. By using the geometric information in the CAD database for the individual structural members, the connections can be represented as logical relationships which can be readily processed by a

computer capable of symbolic processing . Rules can be developed for the sequence in which the connections can be made. This will enable the planner to develop various constructability scenarios based on rules which are established for the erection process and model the erection process in detail. The capture of this construction knowledge in a rule based computer program will also enable the designer to see the consequences of his designs. This research will focus on the application of artificial intelligence to construction planning, while considering future implementation of the CAD link.

## **1.2 Problem Statement**

There is no readily available method for analyzing all the possible crane positions and developing an erection sequence for a steel building. The number of alternate crane positions is very large and consideration of member weights and crane boom interferences make the calculations tedious. A precise mechanism which will assist the planner in determining the optimum crane positioning is needed. CAD and artificial intelligence can be used to develop a computer program that provides the planner with information required to select the most efficient crane for a project.

Such a program must be capable of utilizing information on the characteristics of the structure generated in the design phase without the unnecessary regeneration of data . The planner should be able to input the parameters for the intended crane, while the program develops an erection plan, advising the planner of the optimum positions for the crane and indicating which members can be erected for each crane position. This

information can then be used by the planner to compare cranes which might be used for a project.

### **1.3. Objectives**

In order to solve this problem, this research has the following four objectives.

#### **1.3.1 Understand the Process for Planning Structural Steel Erection and Define Information Requirements**

Identify the major tasks performed in the planning process. Relate planning tasks to the functions performed during the execution of the erection process, in order to develop rules for steel erection procedures and to define the scope of the project. Define information requirements by developing a checklist of the information required to plan structural steel erection in terms of building structure, site, and crane parameters.

#### **1.3.2 Define a Generic Building and Develop Rules for Steel Erection Procedures**

Develop a generic structure for a building adaptable to a computer program. Document methods for erecting structural steel and develop a logical procedure adaptable to a computer program which is consistent with industry practice.



### **1.3.3 Develop a Program for Optimizing the Positioning of a Mobile Crane for Steel Erection**

Based on the rules for erecting structural steel, write a computer program to determine the siting locations for a given mobile crane such that the steel erection for a building proceeds in an orderly sequence with the fewest number of crane set-ups.

### **1.3.4 Test the Program**

Determine the effectiveness of the crane positioning program by testing it for three buildings using four given cranes.

## **1.4. Methods**

The objectives will be performed by the basic steps presented in Fig.1.1.

### **1.4.1 Understand the Process for Planning Structural Steel Erection and Define Information Requirements**

Use the Integrated Building Process Model (IBPM) to establish the relationship of the planning function to the the structural steel erection process. Identify the flow of information required to plan the work. Use the model as a framework for constructing a questionnaire which will be used

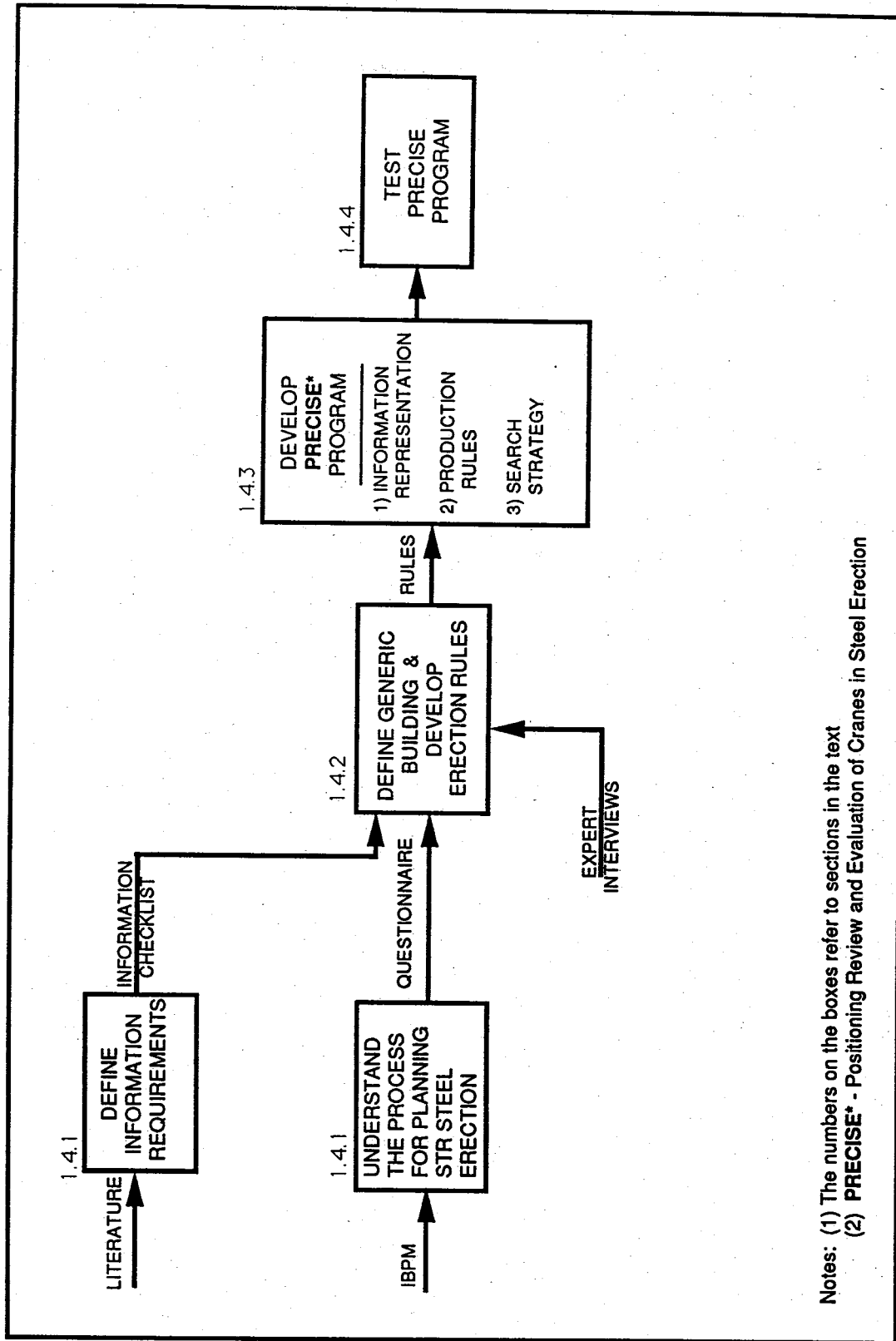

Notes: (1) The numbers on the boxes refer to sections in the text  
 (2) PRECISE\* - Positioning Review and Evaluation of Cranes in Steel Erection

Figure 1.1 Research Methodology for Developing PRECISE Program

with experts to develop the rules for the erection procedures which govern the positioning of the crane and erection sequencing.

Based on a literature search on structural steel erection and crane applications, develop a checklist of information required for the development of the erection scheme. Verify the checklist with experts in industry. Use checklist in conjunction with process model, defining the data input requirements, and developing the knowledge representation for the analysis of the crane problem.

#### **1.4.2 Define a Generic Building and Develop Rules for Steel Erection Procedures**

Select three companies engaged in steel erection and conduct interviews with one expert within each of these companies to determine types of buildings erected and procedures used in erecting structural steel. Based on these interviews, develop a generic building structure and logical rules which can be implemented in a program to determine the optimal locations for a crane.

#### **1.4.3 Develop the Positioning Review and Evaluation of Cranes In Steel Erection (PRECISE) Program**

Develop a program to optimize the crane locations for erecting structural steel as outlined in the following four steps:

- 1) Review literature and determine an appropriate programming environment for solving the crane location problem

- 2) Develop information representation for the generic building and cranes
- 3) Implement production rules which govern the erection of the structural steel based on the results of interviews with industry experts.
- 4) Develop a search strategy to identify the possible locations for setting the crane. Use rules of thumb to limit the search space and be consistent with the constraints imposed by the rules.

#### **1.4.4 Test the PRECISE Program**

Develop a method for the comparing alternate cranes which might be used on a project, based on the number of crane set-ups, the crane productivity, the crane usage cost and any other factors identified during the interview process. Using the crane optimization program, test four cranes on three different buildings to determine the lowest cost crane for each building.

#### **1.5 Scope**

The scope of this research has the following limitations:

- 1) The computer program is limited to positioning mobile hydraulic cranes and developing a sequence for the erection of structural steel.
- 2) The buildings are rectangular single story buildings with straight members that are commonly found in commercial and light industrial construction. A generic building has been developed based on interviews with experts in steel construction.
- 3) The program does not account for obstructions and repositioning the crane to avoid obstructions.

- 4) The software does not take special consideration of varied weights of structural members. A single crane load radius will be selected corresponding to the heaviest member in the structure.
- 5) The program can be utilized by field personnel operating a personal computer at a site.

## **1.6 Summary and Reader's Guide**

Chapter 1 describes the steel erection process, erection planning, and introduces the problem of planning crane positioning when erecting structural steel and the potential benefits from developing a program which will find the crane the optimum crane positions. Chapter 2 surveys recent research on cranes used in construction. It describes the development of the questionnaire used to interview steel erection experts on the planning process and the information requirements. Chapter 3 describes the development of a generic building for this thesis and the development of the rules for steel erection. Chapter 4 provides background on artificial intelligence and the selection of the Prolog programming language for this application. It then describes the program which develops the generic building model and implements the rules for erecting structural steel based on the crane parameters selected by the user. Chapter 5 discusses the results of testing the program using different cranes on different buildings. The development of criteria for comparing the cranes is presented. Chapter 6 concludes with a discussion on the value of the research, problems encountered in developing the program, and suggestions for further research.

## **CHAPTER 2**

### **THE STRUCTURAL STEEL PLANNING PROCESS AND INFORMATION REQUIREMENTS**

This chapter reviews recent research in crane selection and discusses the collection of data on the structural steel planning process and information requirements. The relation of the planning process to the construction process will be explained through the use of the Integrated Building Process Model (IBPM) developed at Penn State. Information requirements for planning steel erection are discussed. The development of a questionnaire and information checklist for collection of data from steel erectors on planning methods and procedures for steel erection is explained. The selection of companies for data collection and the interview process is discussed. The chapter concludes with a summary of the responses to the questionnaire.

#### **2.1 Research in Construction Planning Using Cranes**

Recent research in construction planning for proper crane utilization has focused on expert systems for proper crane selection and optimization of hook position for a stationary crane. Cooper (1987), used a production rule system to select a tower crane for a multistory building. The production rules were developed by interviewing experts employed in a single construction company. The basic rules are: (1) all parts of the building must be overhung by one or more cranes, and (2) the cranes must be capable of lifting materials at a rate that will match the construction schedule. The site

plan is digitized and arranged in zones to determine the maximum lift in each zone. The user selects the crane centers and jib lengths required. The program checks a database of available cranes to determine if the precondition can be met. It then determines mast height and checks to determine if lifting rates match the project schedule.

Wijusundera(1985) developed an expert system for the proper selection of lifting equipment for a construction project. A decision tree was developed based on interviews with experts. The decision tree asks questions about soil conditions, physical parameters of the building, site access, obstructions, period of use and anticipated working loads and provides the user with a recommendation on the appropriate tower or mobile crane. This information was used in a computer program called an expert system shell. The program is also capable of dealing with uncertainty. The researchers noted problems in developing the hierarchy of the decision tree because not all experts interviewed approached the problem by asking questions in the same sequence. Additionally, problems were encountered in weighting the variables and quantifying uncertainty.

Gray(1985) developed a six stage hierarchy for selecting an appropriate crane for a building project which was applied to an expert system. Only tower cranes and mobile cranes were considered, since derricks are not used in Europe. The first step or stage in the expert system is to determine if a crane is required, based on the anticipated loads to be lifted. The second stage is to determine the number of cranes required, given the expected workload. Based on site conditions, stages 3, 4, and 5 determine the appropriate tower crane to be used. If the site area is equal to the building footprint, an internal climbing crane is recommended.

Otherwise the selection may be a stationary external crane or a tower crane on rails.

Stage 6 is an analysis of mobile cranes. Here, critical lifts are examined to develop a crane specification in terms of load/radius and required boom length. The appropriate mobile crane carrier type is determined based on site conditions and maximum load moment. At the end of each branch in the decision process are financial considerations which are to be evaluated if two selections are valid. One shortcoming of Gray's research is that the means for arriving at stage 6 in the decision tree for selecting a mobile crane versus a tower crane is not clear.

Rodriguez-Ramos (1983) developed a mathematical model for positioning a tower crane to minimize the transportation cost to crane destination points. The model is formulated in terms of the crane boom movement with respect to a polar coordinate system. The solution is the best crane hook position between movements. The distribution of load destination points is  $r_i\theta_i$ , for  $i=1, n$ , is expressed in polar coordinates relative to the crane position. A weighting factor  $W_i$  is applied to each load which represents the transportation cost per unit of angular or radial travel time multiplied by the number of cycles for each destination point. Using a graphic method, the best pick or unloading point is found which results in the least total angular and radial movement of the crane when summed over all of the lifts. The user is required to select the center location for the crane, and the program then finds the best angular and radial position to make the lifts.

In summary, most recent research has been on selecting the proper type of crane based on rules of thumb. The user must select the crane



position(s) and the crane coverage area is verified. This assumes that an expert is available to do this work. Additionally, these programs look at coverage areas or zones for the crane, but do not look at the individual elements and the effect erection sequence may have on crane's ability to install that element. No research has been done on developing a program which will assist the planner in selecting the positions for setting up the crane based on required erection sequences. The following section presents a framework for the sequence of events required to erect structural steel.

## **2.2 Integrated Building Process Model**

The Integrated Building Process Model (IBPM) provides a method for integrating crane planning into the entire planning and construction process (Sanvido, 1990). One element of this process, the Construct Facility model (Figure 2.1) provides a methodology for describing the dynamic processes required to convert a site and resources into a facility. It identifies the four key activities as: (1) Acquire construction services, (2) Plan and control the work, (3) Provide resources, and (4) Build the facility. The model is applied to defining the structural structural steel erection phases below.

The acquisition of construction services is accomplished by the Owner or general contractor and formalized with a contract or subcontract. The planning and control of the work is accomplished in the advance planning phase. The provision of resources requires delivery of materials from the fabrication phase along with provision of equipment and labor. Building the facility is executed in the erection phase with shakeout,

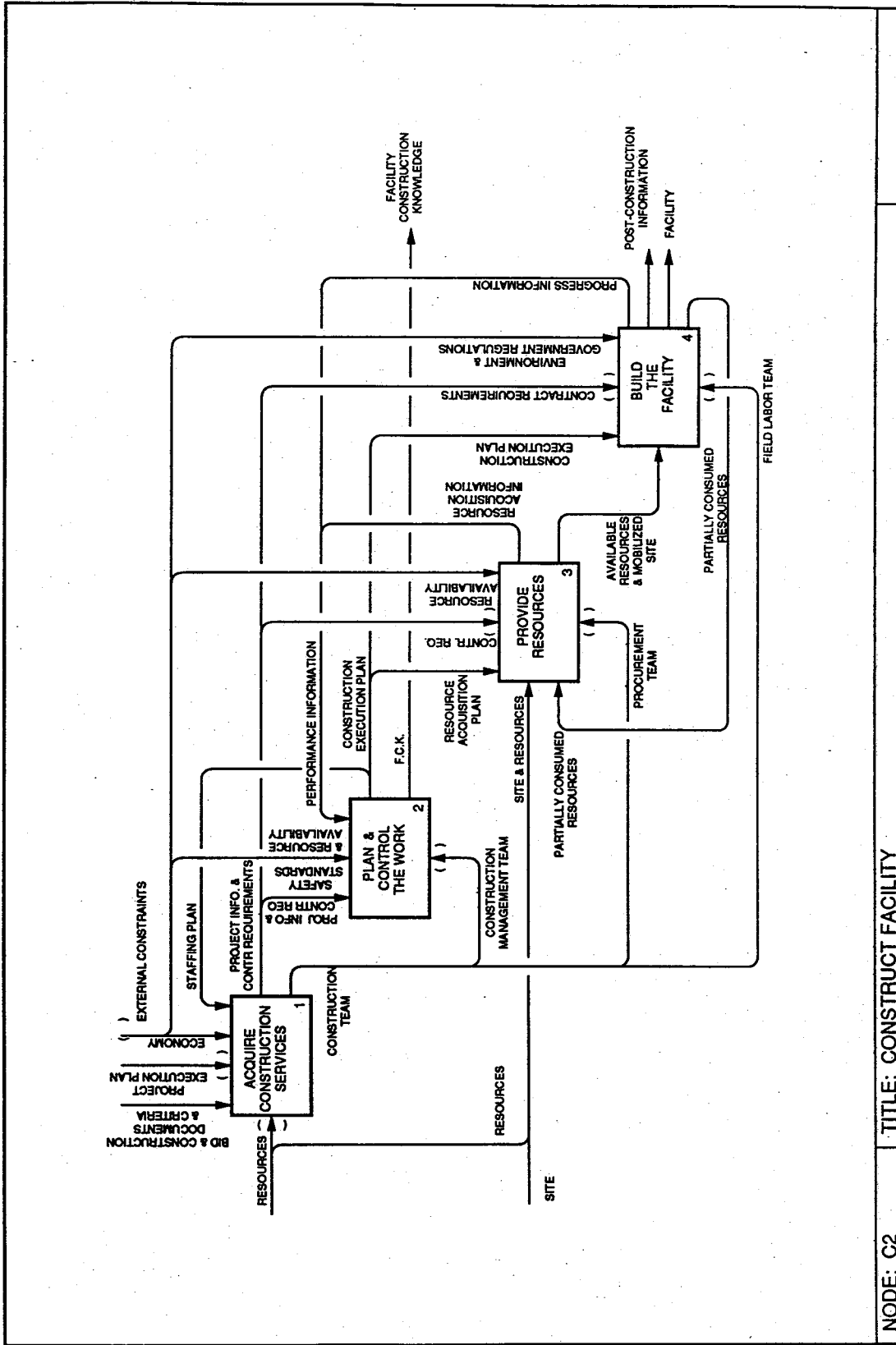

NODE: C2 TITLE: CONSTRUCT FACILITY

Figure 2.1 Construct Facility Model (Source: Sanvido, 1990)

placement of members, plumbing and aligning, and bolt tightening and welding.

Planning and controlling the work can be further subdivided into activities as shown in Figure 2.2. PRECISE, the program developed as a result of this research is a planning tool which can be used to perform function C212 in Figure 2.2, Select Work Methods. The information developed can also be used in evaluating schedules, estimates and available resources for a project. PRECISE can also be linked to electronically generated drawings, by using the geometric database of the structural elements as an input to the PRECISE program. The crane locations, erection envelopes and sequence of erecting structural members determined by the PRECISE program can then be transferred back to the CAD drawings.

### **2.3 Definition of Information Requirements**

A literature search was conducted of information generated in the design, fabrication and planning phases which could be related to the information arrows on the Develop the Construction Plan of the IBPM. Several sources were found: Rapp, 1980; Shapiro, 1980; AISC, 1983; ASCE, 1988, Oppenheimer, 1960, Ricker, 1988. This information from the literature was compiled as a checklist (Appendix B, Section B.3) which was subdivided into two categories: contract documents and project information. The checklist was reviewed during the interviews to verify the information required for planning. The information requirements were used to define the data input and output criteria for the PRECISE program.

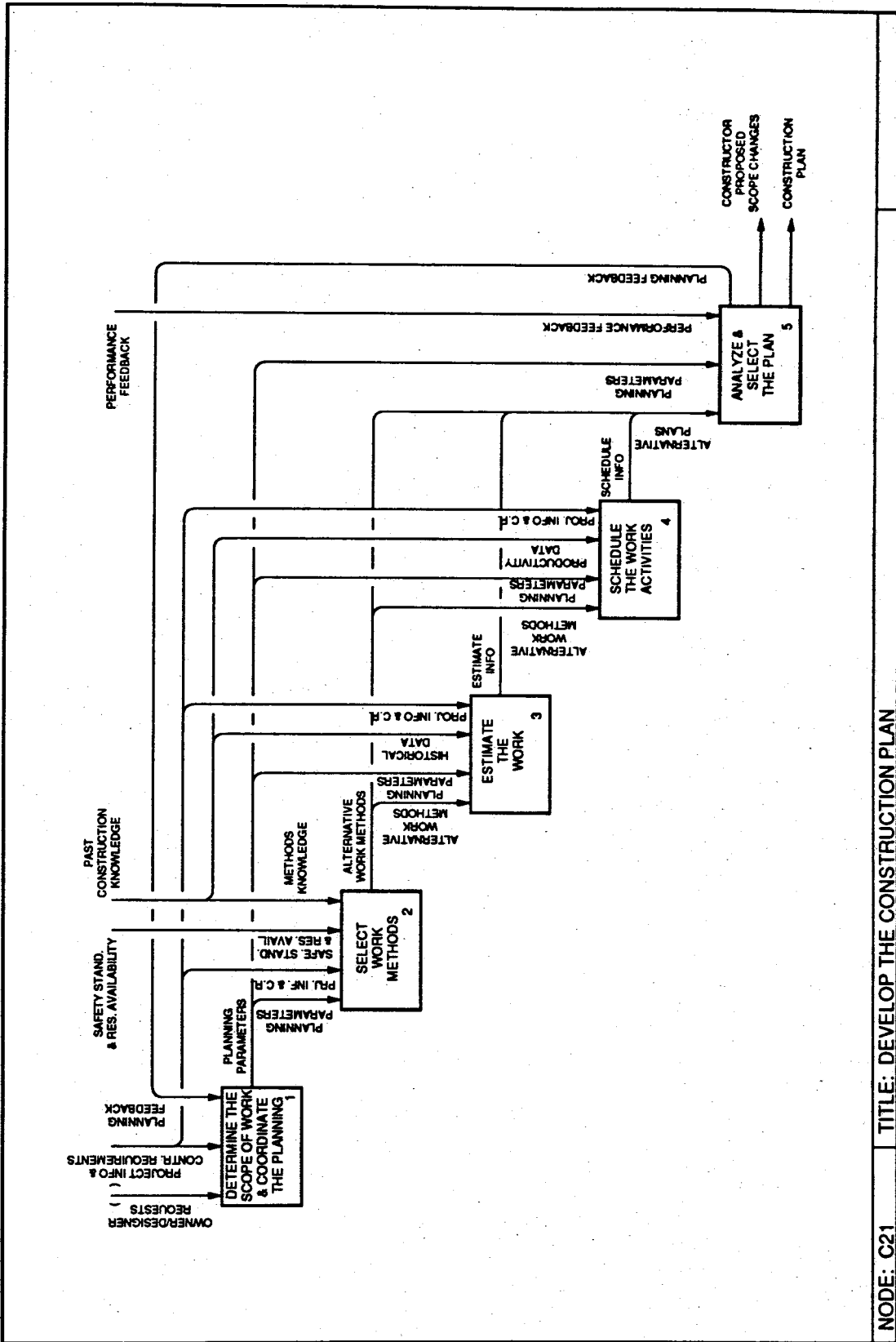

NODE: C21 TITLE: DEVELOP THE CONSTRUCTION PLAN

Figure 2.2 Develop the Construction Plan (Sanvido, 1990)

## **2.4 Questionnaire Development**

In order to put the PRECISE program into the context of the activities required to build the entire project, the Integrated Building Process Model for Developing the Construction Plan (Figure 2.2) was used to develop a questionnaire for use with steel erectors. The questionnaire (Appendix B, Section B.2) served three purposes: (1) to understand how companies accomplish the planning function, (2) to obtain data on erection methods which could be converted into rules for the PRECISE program, and (3) to determine the information required for the planning functions.

The questionnaire was divided into five categories, based on the planning functions. These categories were: (1) Determine Scope and Coordinate Plans, (2) Select Erection Methods, (3) Estimate the Work, (4) Schedule the Work, and (5) Analyze and Select the Plan.

The questionnaire focused on the function for Selecting Erection Methods in order to develop rules for the PRECISE program. Companies were asked specific questions on: (1) Methods of determining equipment to be used, (2) Methods of determining erection sequencing, (3) Methods of determining crane set-up positions, (4) Effects of delivery and unloading requirements on erection schemes, and (5) Methods of determining crew sizes for erecting steel.

## 2.5 Selection of Experts and Data Collection

To understand the steel erection process and the required planning parameters used in erecting steel for single story steel framed buildings three interviews were conducted with steel erectors located in central Pennsylvania. The criteria for selecting companies were: (1) The company should use mobile cranes for erecting steel, and (2) The company should erect buildings over 20,000 sq. ft. The intent of these interviews was to survey the methods used for planning structural steel erection and to determine how these plans related to the overall planning of the construction process. These interviews attempted to elicit specific rules which can be used in the development of the production rule system for steel erection.

Two of the companies discussed prefabricated single story metal buildings which utilize light weight tapered columns and beams that are erected as frames. These buildings are generally warehouses and manufacturing facilities. The third company discussed conventionally framed metal buildings. These buildings are frequently encountered in warehouses, manufacturing facilities and shopping centers.

Additionally, manufacturers and contractors were contacted and furnished representative drawings of buildings of prefabricated metal buildings and copies of erection procedures. Five site visits were made to a local project site, where one of the contractors was erecting a multistory condominium using truss joists. Informal interviews were conducted with the job superintendent, foreman, and crane operator to discuss general problems encountered in steel erection. Interviews were also conducted

with a crane distributor to get a perspective on crane usage needs by steel erection contractors.

## **2.6 Interview Procedure**

A consistent procedure was used for each of the case studies. The interview started with an introduction where the interviewer explained that this was a research project to utilize cranes more efficiently in erecting steel. The interviewees were advised that the research was focused on single story structures and planning in terms of crane selection and crane positioning.

The interviewees were shown a simplified version of the IBPM for Developing the Construction Plan (Appendix B, Figure B.1) and advised that a questionnaire had been prepared that paralleled the diagram. The questions were open ended and the interviewees were free to explain in as much detail as they wished. Follow up questions relating to the planning model and information checklist were also asked to maintain the focus on crane planning. All interviews were tape recorded.

## **2.7 Responses to Planning Questionnaire**

A summary of the questionnaire responses is provided in this section. Detailed responses were transcribed as case studies in Appendices C, D and E. Details of erection procedures are discussed in Chapter 3. Five site visits were made to one of the contractor's local sites, where observations confirmed the procedures described in the case studies. Case studies were

used because interviewees frequently provided information that was more relevant to another function than the one in question.

### **2.7.1 Determine Scope and Coordinate Plans**

Prefabricated metal buildings are usually built on a design-build basis, where the contractor provides the owner a design of a standard building with modifications which may be required to meet the owner's special needs. The scope of the project is defined in the design-build contract agreement, developed by the constructor and the owner. For conventional buildings, the steel erector is generally a subcontractor and obtains information on the project scope in the form of drawings and specifications. Steel shipments are planned during this phase. For projects greater than 50,000 sq. ft., the project is broken up into divisions of multiples of 50,000 sq. ft. Each division is shipped at one time. Shipping sequences are based on site layout and owner's occupancy requirements.

### **2.7.2 Select Erection Methods**

All contractors interviewed used their own equipment and avoided leasing. They attempted to match equipment to the project by using their largest cranes on their largest projects. Both of the companies involved in prefabricated metal building erection used forklifts to feed material to the crane.

Two of the companies left the details of crane positioning entirely to the foreman in the field. One company which was also engaged in



multistory erection did some planning in the office. They provided a computer output sheet which was used to determine boom clearances for different angles and distances from the structure. All of the companies agreed that because of unexpected contingencies such as open trenches and underground utilities that the foreman must be given as much flexibility as possible to make decisions in the field. Details of erection procedures are discussed in Chapter 3.

### **2.7.3 Estimate**

Estimates are prepared based on historical productivity rates. Productivity rates for conventionally framed buildings are based on the number of pieces of steel erected per day, which is typically 50 to 65 per day (Marker, 1989). The overall estimate will be affected by the type of connections which are required. If there are a large number of welded or bolted moment connections, the estimate will have to be increased to reflect the additional effort required for these connections.

Productivity for pre-engineered metal buildings are based on the the number of row frames that can be erected in a day. Row frames are the major column and roof beam assemblies which span across a building. The average is two frames per day, depending on the width of the building for a normal five-man crew (Anderson, 1989).

#### **2.7.4 Schedule**

All of the respondents use bar charts for scheduling, but only one specifically mentioned using CPM networks. CPM networks are used on larger projects (Lundy, 1989). Schedule dates are determined based on owner needs, contract milestone dates, material delivery schedule, and available labor and equipment resources. The delivery schedule is determined by the fabricator's or building manufacturer's production capacity. One contractor noted that the most difficult resource to schedule between various projects was competent supervision (Lundy, 1989). Productivity rates used in the estimate and available labor and equipment resources are used to determine schedule durations.

#### **2.7.5 Analyze and Select the Plan**

None of the companies performed a formal analysis of alternate erection plans and their effects on the schedule and estimate. One company performed an analysis and planned crane positions. None of the respondents have comparative productivity data on different pieces of equipment. The erection plan is an informal plan determined by the equipment and labor available. One erector stated, "You can always do a small job with a big crane, but you can't do a big job with a small crane" (Marker, 1989).

construction information can also be assigned to each member for other applications.

The generic building consists of three different structural elements: columns, beams, and purlins. A column grid is generated corresponding to the number of columns in the X and Y directions and the column spacing in each direction. Beams run in the X-direction and are supported by columns at elevation "Zb." Purlins run in the Y-direction and are attached to beams at each column. Each structural element is given a unique identification number which is stored with the geometric information. Figure 3.1 shows an example of a generic building.

### **3.3 Key Parameters for Cranes**

Cranes which are normally encountered in this type of construction range in capacity from 20 tons to 150 tons with operating radii from 70 ft. to 170 ft. The loads encountered in the erection of single story metal buildings are normally 1000 lbs. or less (Anderson, Lundy). For most crane load charts, these loads are at or near the maximum radius at which the crane can operate. Key crane parameters are boom length and operating radius.

Additionally, the location of the horizontal boom pivot on the crane body must be accounted for when setting the steel in place, so as not to cause an interference between the crane and the steel which is being erected. To account for this, a setback dimension is used to dictate the minimum distance between the center of the crane swing circle and the row of columns closest to the crane. The other important crane dimension is the

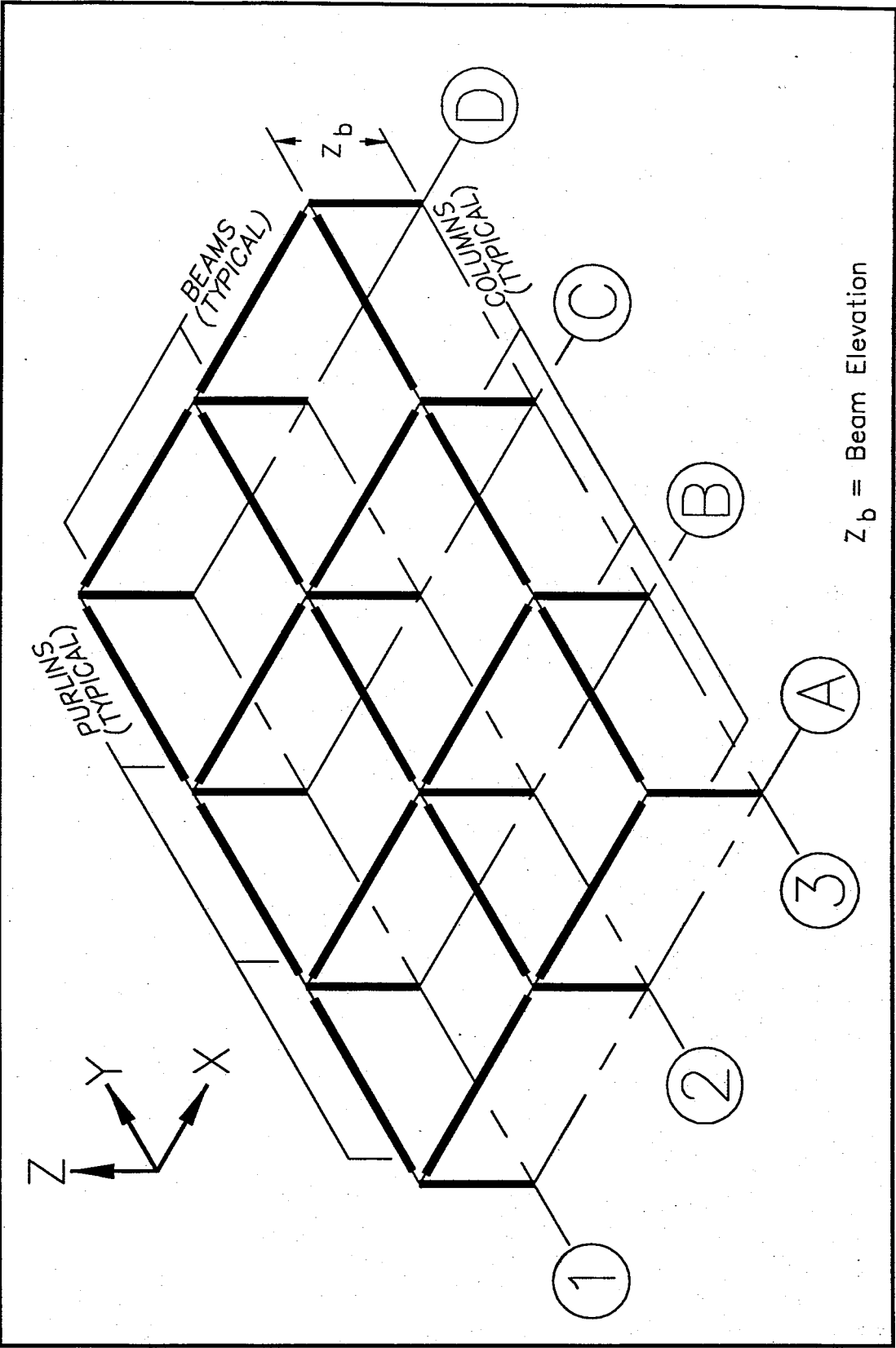

Figure 3.1 Generic Building

height of the vertical boom pivot above the ground. Both of these dimensions are critical when checking boom interferences.

### **3.4 Analytical vs. Relational Approach to Crane Positioning Problem**

Two basic approaches were considered for developing a solution to the crane positioning problem. They were (1) the "analytical" approach, and (2) the "relational" approach.

Using the "analytical" approach, the center of each structural member is represented by a point in (x,y,z) space, with a corresponding load circle for the crane. The load circle is defined as a circle whose center is the center of gravity of a member and whose radius is equal to the maximum crane radius which can lift the member. Each member can be set by the crane from any point within its load circle. Optimum crane positions are locations with the highest densities of areas enclosed by load circles. An attempt was made to solve this problem graphically for the simple structure shown in Figure 3.2. It quickly became evident that the analytical solution would be very complex. Each member requires its own equation for a load circle. Thus for a structure of 500 members, there would be 500 equations! Additionally, preconditions on the erection sequence would require a precedence mechanism for finding certain intersection sets. Connection requirements for a beam would require that it be excluded from an intersection set if both columns to which it connected were not in the intersection set.

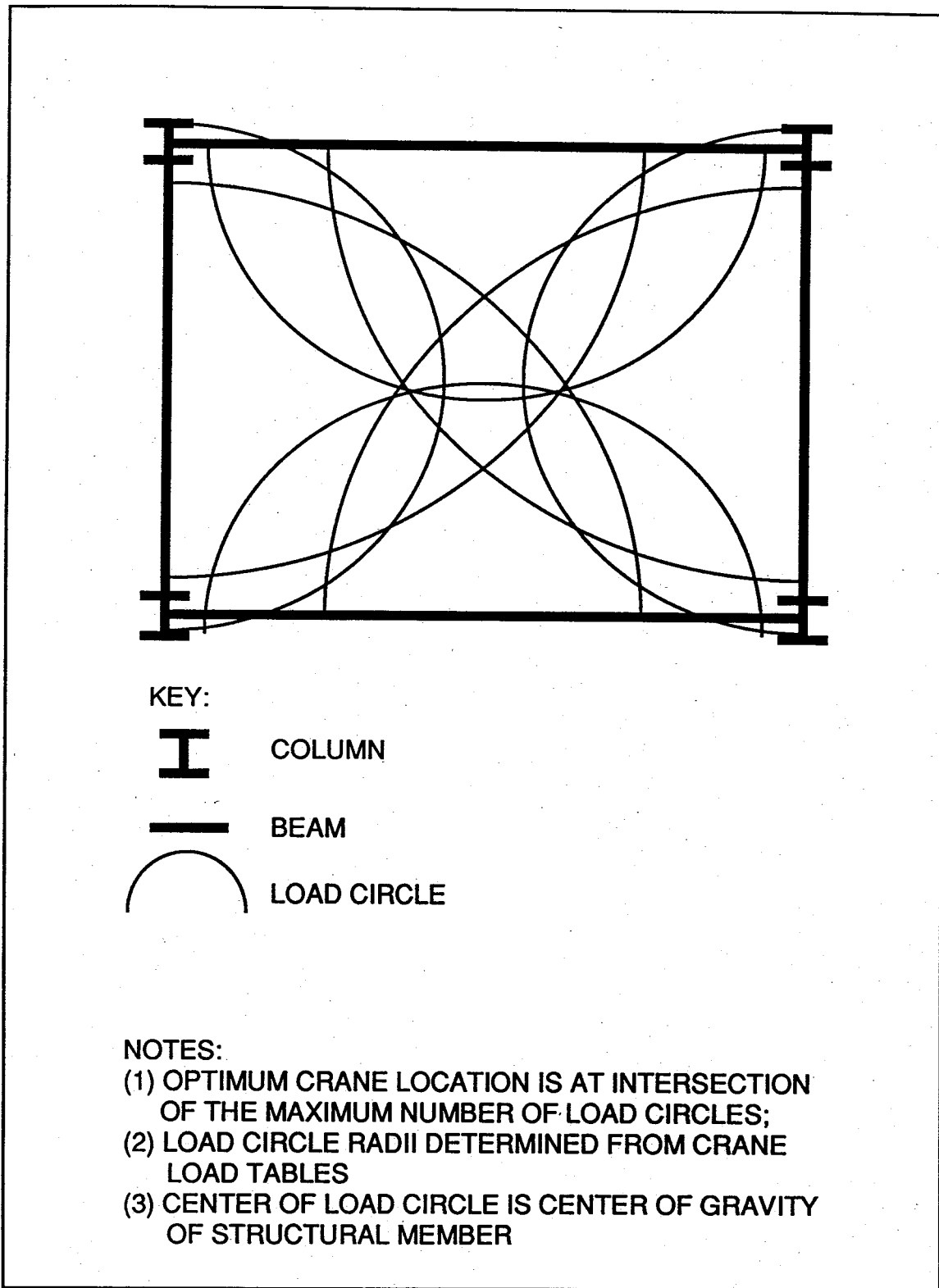

Figure 3.2 Graphic Representation of Analytical Approach to Locating Crane

After abandoning this approach, the "relational" approach was considered. The relational approach develops the relationships between the structural members in the building and the crane to the structure through the creation of an erection envelope around the crane. The erection of structural steel using a crane can be considered a position search process, where the desired end result is the establishment of positions which permit the crane to completely cover the structure in the least number of moves. The crane operates in a semicircle from within the structure, backing out as the steel is erected. The envelope is a rectangle inscribed within this semicircle. Starting at one end of the building, the "position search" finds the combination of rectangles which will permit the crane to erect the greatest number of members from each position, while minimizing the number of positions. This will yield the highest average number of pieces erected per crane position. This combination determines the pass widths at which the crane will operate as it erects the steel.

### **3.5 Development of Rule Base**

This section begins with a description of the development of the building. The importance of orderly sequencing and the specific rules for erecting are explained.

#### **3.5.1 Generic Building Development**

Based on interviews with experts , observations, and data analysis, the generic building for the production rule system was developed. This is

an idealized composite of prefabricated metal buildings and conventional buildings. Prefabricated metal buildings use tapered columns and beams which make up row frames or portal frames that span the building. The beams are connected to the top face of the columns and the roof is sloped. Beam connections are frequently located between columns. The frames are tied to each other by closely spaced roof purlins, which bolt to the beams. Purlins support the metal roofing panels.

Conventionally framed single story buildings use straight columns with girders instead of beams, and joists instead of purlins. Girders connect to columns and may run along the length of the building or across the building. Joists span between girders and support roofs which are generally flat. For single story construction, girders and joists are generally light weight truss type joists.

The model building has straight columns with beams which span across the building and connect to the columns. Purlins connect to beams and are located only at columns. This arrangement requires that beams be set prior to purlins, and will require that the crane reach over the beams in order to set the purlins. Interference checking is required to verify that the crane does not interfere with the beams in the process of setting purlins. Beams and purlins are at a single elevation, which assumes a flat roof. The building and crane calculations are based on centerline dimensions of members.



### **3.5.2 Steel Sequences and Relationships**

Structural steel must be erected in a logical progression, building on steel elements which have already been erected. The crane must be located to operate within the radius of the area of steel being erected, without interfering with any of these members after they are set in place. The relationships between the structural elements are the connections between the members, which must be made as the steel is erected. Columns and two dimensional frames must be tied to the overall frame with purlins as quickly as possible for safety reasons. Additionally, to simplify plumbing and alignment for the erection crew, newly erected members are to be tied to the existing structure as they are erected. Difficulties are frequently encountered when separate sections of the building are erected, and are then tied together.

### **3.5.3 Specific Rules for Erecting Steel**

The following sections are a distillation of the erection procedures gleaned from interviews with experts and applied to the single story generic steel structure. Table 3.1 summarizes the information sources for these rules.

Table 3.1 Sources of Procedures

COMPANY	A	B	C
TYPE OF BUILDING	CONV	PRE-FAB	PRE-FAB
RULES			
DIVIDE BUILDING	X	X	X
FIND CRANE LOCATION	X		
START AT END WALL	X	X	X*
ERECT ROW FRAMES	X	X	X
ERECT FROM ONE SIDE IN SEQ	X		
WORK BACK TOWARD CRANE	X	X	X
ERECT EQUAL SIZED FRAMES	X		
ERECT PURLINS		X	X
CONSIDER BOOM INTERFER.	X	X	
FIND NEXT POSITION	X		
<p>X* - ON BUILDINGS WITH BRACING BETWEEN 2ND AND 3RD COL ROW, THE 2ND AND 3RD COL ROWS ARE ERECTED PRIOR TO THE END WALL</p>			

### 3.5.3.1 Divide Building Width If Required

If the crane cannot span the building, the building must be divided into multiple crane pass widths. Various possibilities may exist for dividing the building. Experts did not give specific methods for dividing the building, but suggested that the building should be divided into equal areas based on the number of crane passes required (Marker, 1989; Lundy, 1989).

Problems with this method are discussed in section 3.6.2.

Since beams are not considered to be self-supporting, a column must be at each end of the crane pass width. The crane pass width will be an integer multiple of the column or bay spacing. Bay spacing is defined as the distance between two adjacent columns. The procedure for finding the combination of pass widths is discussed in section 4.6.6.

### 3.5.3.2 Find Crane Location

Starting at one end of the building, the first crane position must be within reach in terms of radius and load rating of the end row of columns. Since these loads generally do not limit the crane radius, the cranes erecting the building will be considered to operate with the same radius for all structural members. In order to erect the maximum number of members, the crane position should be within the building lines, which is usually possible in single story construction with hydraulic cranes. This position is the intersection of the arcs whose centers are the corner column and whose radius is the crane operating radius as shown in Figure 3.3.

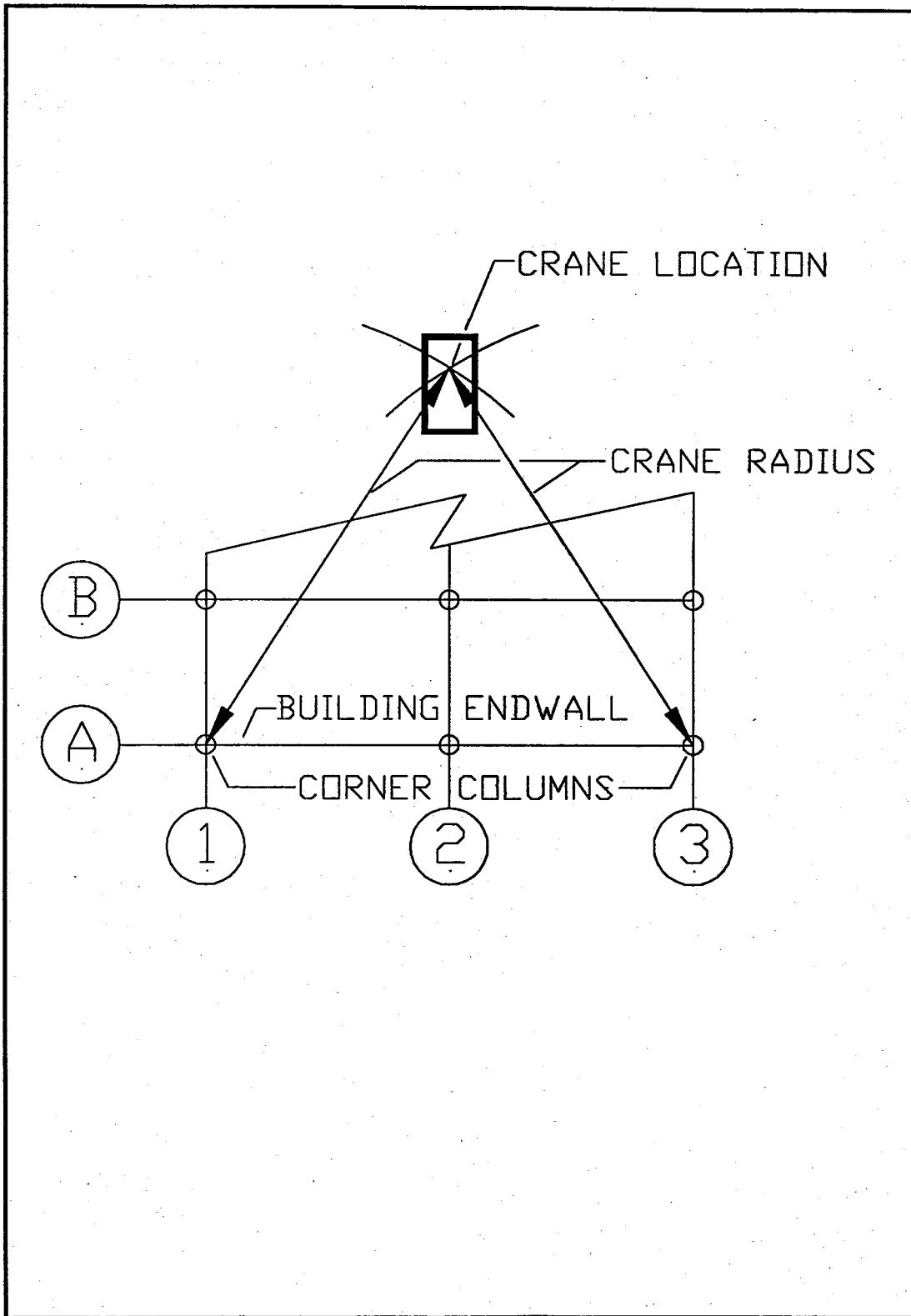

Figure 3.3 Determining the Crane Location for a Given Passwidth

### 3.5.3.3 Erect Row Frames

Each row of columns and interconnecting beams may be considered a row frame. It is desirable to begin erecting those members most distant from the crane and work back toward the crane, erecting one row of columns and interconnecting beams at a time. This permits the crane operator to work with an unobstructed view. Several columns may be erected at a time, but since they are unstable, it is necessary to connect them with beams as soon as possible.

Each row frame of columns and beams must be the same width as the crane pass width. Because the crane swing is a semicircle, the operating width of the crane increases as each row of columns and beams approaching the crane is erected. It may seem logical for the crane to set all members within its swing circle, but if the crane is allowed to encroach on the adjacent pass width and set columns and beams in that area, problems may develop when the crane moves into that area. The crane will now have to reach over these columns and beams in order to set the end row of columns, which is undesirable. The crane operation area or "envelope" will be a rectangle inscribed within the crane swing semicircle. The width of the erection envelope is the passwidth of the crane. Figure 3.4 illustrates a typical erection envelope.

Beams must be set in sequence, from one side to the other. Under circumstances where the crane is located on or near a column line, it may seem desirable to set outside columns and beams, leaving out center members which interfere with the crane. This would allow the crane to be positioned further back when it relocates. However difficulties may be

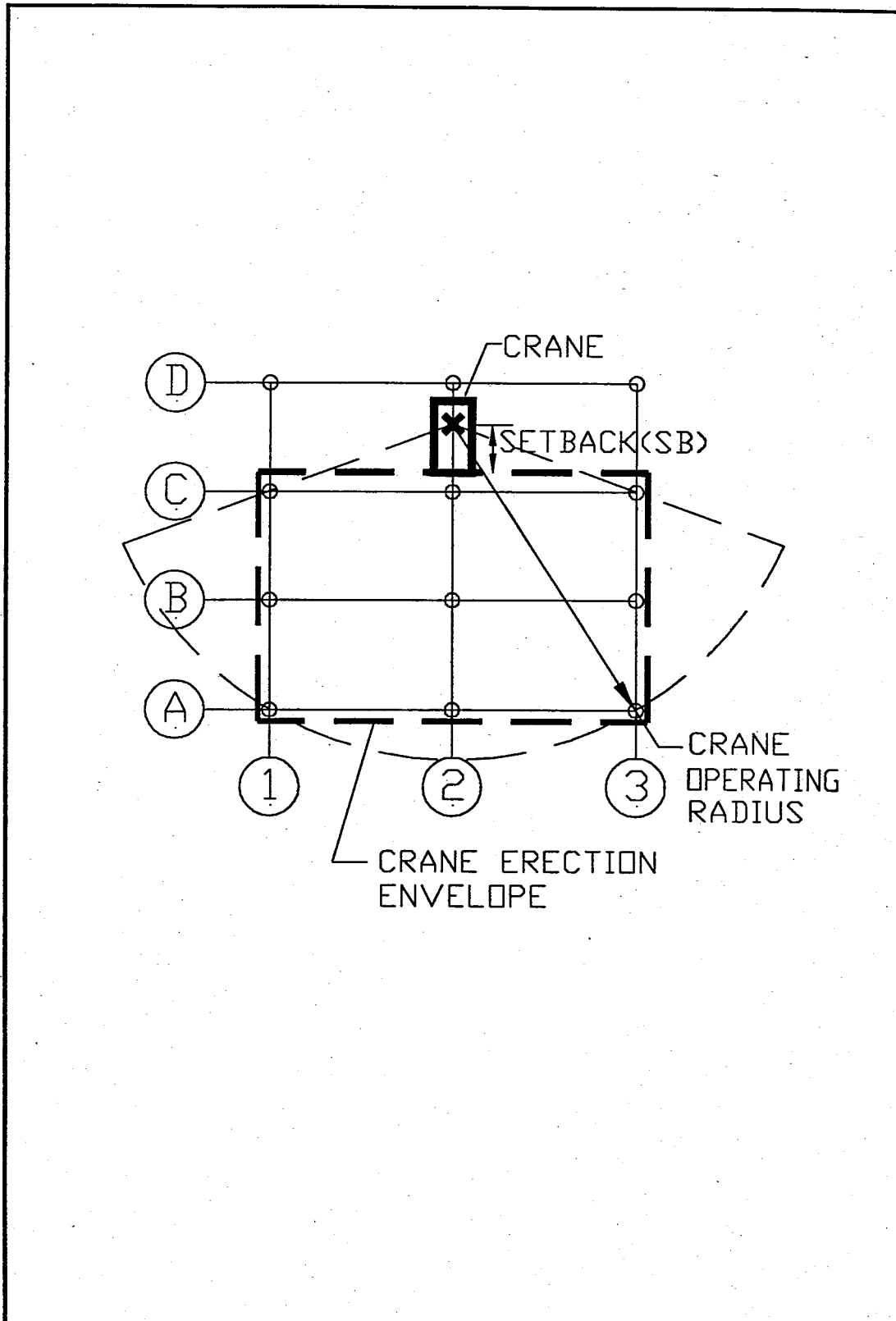

Figure 3.4 Crane Erection Envelope

encountered when fitting the final center beam in place, requiring the use of cables and turnbuckles to plumb the steel. (Marker, 1989). The depth of the erection envelope will be reduced by the setback requirements for the crane.

Pass widths must be equal to full bay spacings. After the crane makes a pass, rather than the use the common column on the next pass, it may seem more efficient to use the center of the adjacent beam as a basis for locating the crane. This would narrow the width of the pass by one half of a bay spacing, permitting the crane to set back further. However, when there are fit up problems connecting the beam to the column erected in the previous pass, the crane must span the full bay in order to reach over the end of the beam and make the column connection.

#### **3.5.3.4 Erect Purlins**

Purlins are erected between row frames after each row frame is erected. The normal erection sequence is to erect a row of columns, then to erect the interconnecting beams as shown in Figure 3.5. Boom interferences as shown in step 3 of Figure 3.5 are explained in the next section. Purlins are then bolted to the beams, stabilizing the frame. Wind loads require that frames be connected as they are erected.

#### **3.5.3.5 Resolve Boom Interferences**

In the process of erecting a row of purlins, the crane must reach over beams which are already in place. In some cases the crane boom may interfere with one or more beams. Interferences will most likely occur with

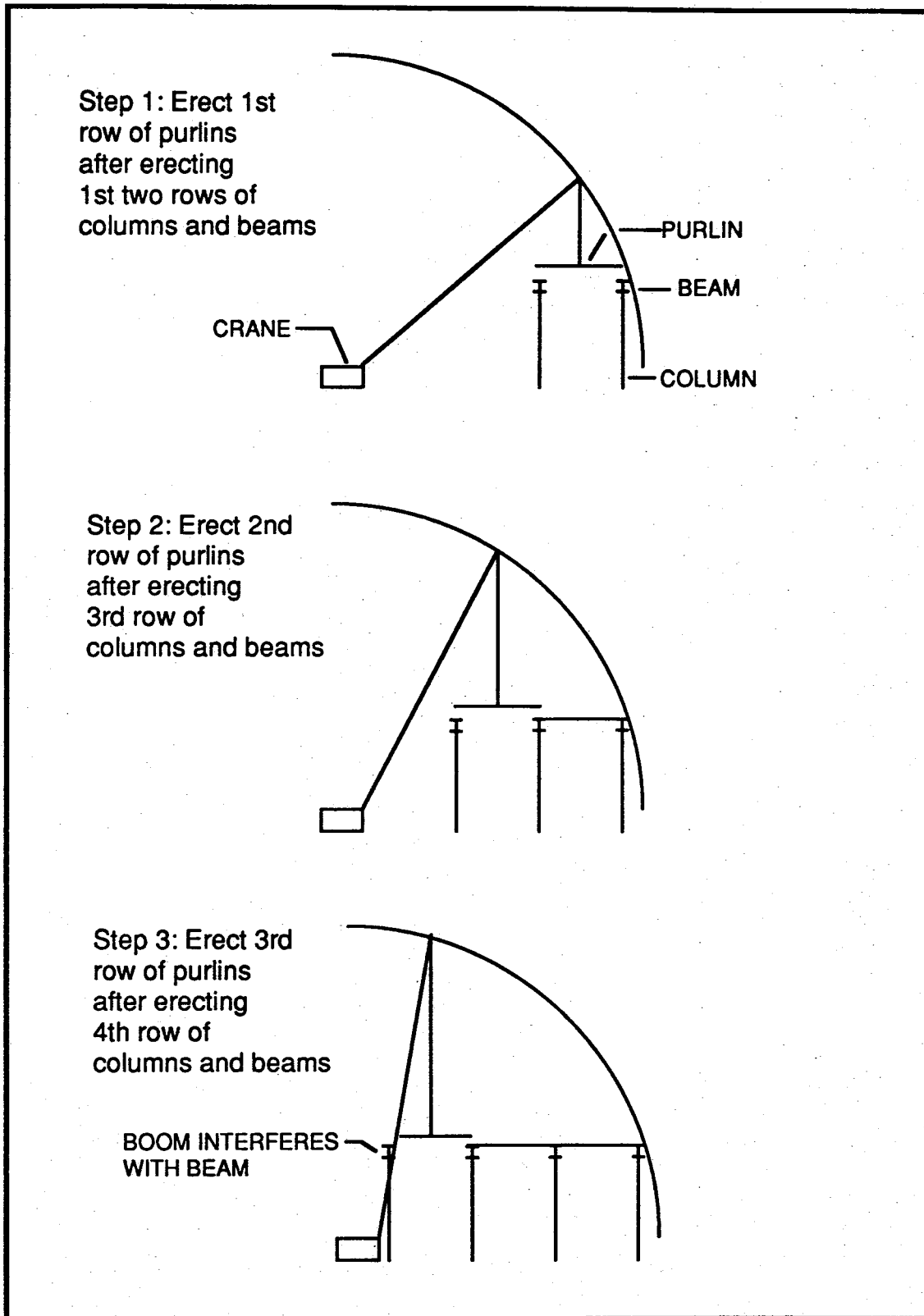

Figure 3.5 Purlin Erection Sequence



rows of beams which are closest to the crane. If there is a boom interference with any of the beams closest to the crane, it will be necessary to check the next row of beams for an interference. This procedure must be repeated until a row of beams is found with no boom interference. Once a row of beams is clear of the boom, it is unnecessary to check any of the rows further away from the crane. As can be seen from Figure 3.5, the boom clearance increases as the distance from the crane increases. The geometric considerations for determining whether an interference exists will be discussed in a later section.

If an interference exists in setting a row of purlins, the interference may occur only in setting the outer purlins. As the crane swings from over-the-rear to over-the-side operation, the boom angle required for setting the purlins decreases at a faster rate than the interference angle between the beam and the crane. The result is that interferences for different configurations will occur at the sides and possibly not in the center. In these instances, there is no advantage to setting the pieces in the center, since the outer purlins will limit the next crane location.

The interference will require that the erection envelope be decreased to exclude the row(s) of beams causing the interference. Since the columns and beams will be within the crane swing circle governed by the location of the purlins, it is safer to erect these members after the crane has been relocated, rather than to leave them standing unbraced while the crane moves.

### **3.5.3.6 Find the Next Crane Position**

When locating the next crane position, a similar approach to finding the initial crane position is used. The crane will be located at the intersection of arcs whose centers are the center of gravity of the outside purlins in the crane pass width. It is generally not necessary for the crane to be able to reach over the ends of these members, because they are light and can be easily handled by the ironworkers connecting the steel. The erection envelope will be the same width as that for the first crane position and the depth will be reduced by the set back requirements and any interferences which may be encountered. This process is repeated until the crane reaches the end of the building. If more than one pass is required for the crane to erect the steel, this process will be repeated for each pass.

## **3.6 Additional Considerations in Crane Positioning**

During the process of developing the program several considerations became apparent which must be taken into account when planning crane positioning. These are discussed in the following sections.

### **3.6.1 Wide Crane Envelopes**

Generally, it can be assumed that the least number of paths traveled by the crane will lead to the fewest number of set up points required by the crane to erect the building. The least number of set up points will also lead to the highest average productivity per set up point.

This may not, however, result in the most efficient utilization of the crane as illustrated in Figure 3.6. If the crane envelope is wide, only one row of columns and beams can be erected because the depth of the envelope is very shallow. However, if the building is divided in two passes, the crane can set three rows of columns and beams from two positions, resulting in a 50% increase in productivity.

### 3.6.2 Building Wider than Crane Operating Width

If the crane operating width is equal to the number of bays, only one pass is required by the crane to erect the building. However, if the operating width of the crane is less than the number of bays, various crane pass combinations may exist. During the course of interviews, all respondents noted that the buildings had to be subdivided if the crane could not reach the sides when placed in the center. However, none had any specific method.

Fig 3.7 illustrates an example of a building which is 10 bays wide and has a crane operating width of 3 bays. The minimum number of passes required by the crane to erect the building is 4. Two of the possible pass width combinations are [1,3,3,3] and [2,2,3,3]. These combinations will yield differing productivity rates. Other combinations also exist. It is necessary to generate these combinations in order to determine the average productivity for each position. The average productivity of the representative crane positions for each pass combination can be evaluated and used as an indicator of the most productive pass combination, which will yield the best crane positioning plan.

CASE I: CRANE SPANS ENTIRE BLDG

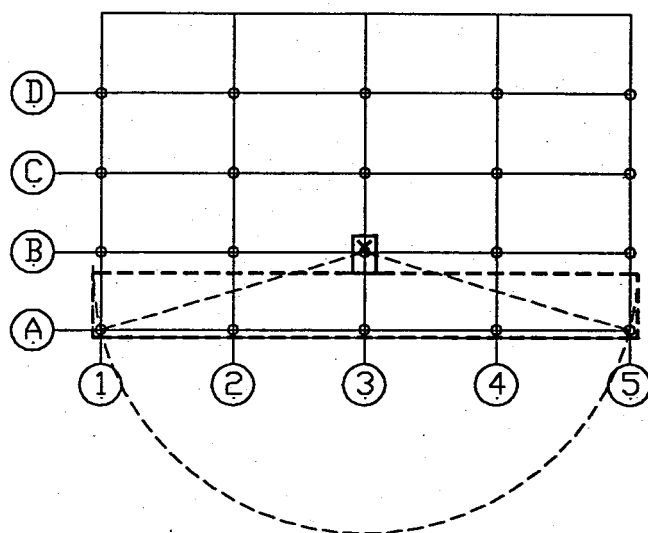

AVG = 1 ROW / 1 CRANE SETUP

CASE II: CRANE SPANS 1/2 BUILDING WIDTH

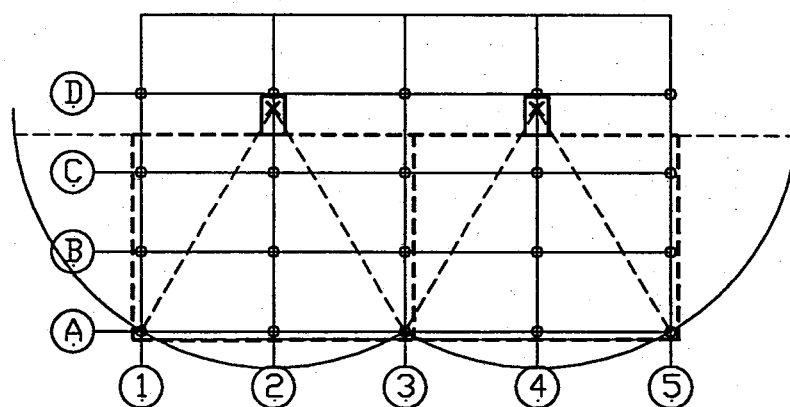

AVG = 3 ROWS / 2 CRANE SETUPS

Figure 3.6 Effect of Reducing Crane Envelope Width

NO. BAYS = 10  
 MAX. CRANE OPER. WIDTH = 3 BAYS  
 CRANE PASSES REQ'D = 4

CASE I:

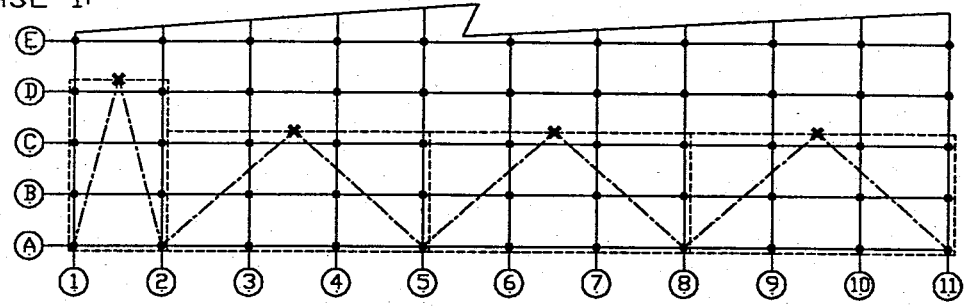

PASS WIDTH COMBINATION = [1,3,3,3] BAYS

CASE II:

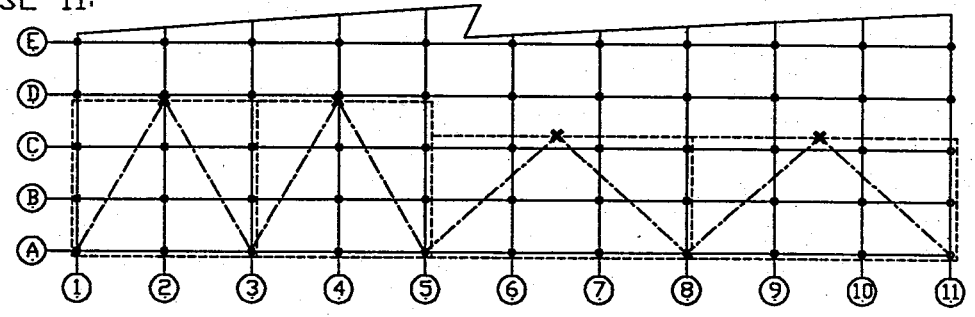

PASS WIDTH COMBINATION = [2,2,3,3] BAYS

\*CRANE POSITION

Figure 3.7 Alternate Crane Pass Width Combinations

### 3.6.3 Boom Interferes with Previously Erected Members

Two of the experts considered boom interferences to be an important factor when planning steel erection. Lundy noted that boom interferences are a factor when setting roof bundles in place on top of purlins in prefabricated metal buildings and Marker mentioned that they were a major factor in multistory erection. Since the generic model considers only structural members for a single story structure, it was decided to develop a mechanism for checking boom interferences based on the rules applied. The rule that beams be installed prior to purlins, requires consideration of boom interferences as the crane reaches over beams to install purlins.

It is necessary to check all of the purlins in a row to verify that there are no boom interferences. This is accomplished by verifying that the boom angle ( $\Theta$ ) required to set a purlin is greater than the boom interference angle ( $\Theta_i$ ) as shown in Figure 3.8. The boom angle is the angle made by the boom as it sets a purlin and is given by the formula:

$$\Theta = \cos^{-1} \left( \frac{S}{BL} \right)$$

where: BL = boom length

S = distance from the crane to the purlin center of gravity and is given by the formula:

$$S = \sqrt{(X_c - X_p)^2 + (Y_c - Y_p)^2}$$

where:  $X_c$  = crane location in the X-direction

$X_p$  = purlin center in the X-direction,

$Y_c$  = crane location in the Y-direction, and

$Y_p$  = purlin center in the Y-direction

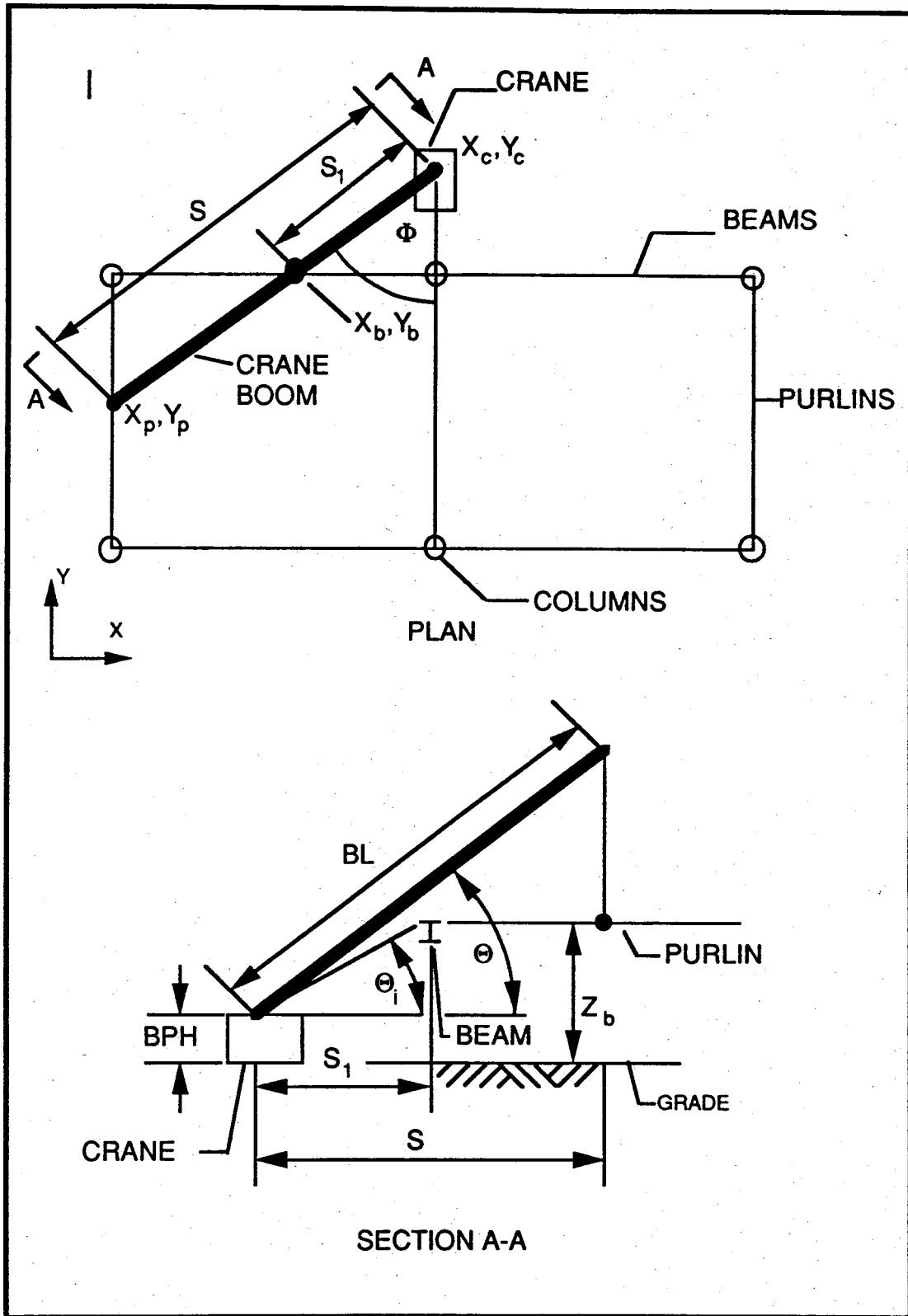

Figure 3.8 Determine Boom Interference angle

The boom interference angle ( $\Theta_i$ ) is in the vertical plane of the crane swing angle ( $\Phi$ ). It is made by projecting a horizontal line from the boom pivot and a line from the boom pivot to the point where the beam intersects the plane of the crane swing angle ( $\Phi$ ). The crane swing angle is:

$$\Phi = \tan^{-1}\left(\frac{X_c - X_p}{Y_c - Y_p}\right)$$

The horizontal distance from the crane to the beam intersection point is:

$$S_1 = \left(\frac{Y_c - Y_b}{\cos \Phi}\right)$$

where:  $Y_b$  = location of the beam in the Y-direction.

The interference angle is:

$$\Theta_i = \cos^{-1}\left(\frac{S_1}{Z_b - BPH}\right)$$

where: BPH = boom pivot height.

$Z_b$  = beam elevation

### 3.7 Summary

This chapter has described the key parameters required for developing a generic building and the crane to be used in the crane positioning program. The use of the "relational" approach to crane positioning has been justified. The development of the rule base for erecting structural steel has been explained. Using the model building and the rules for erecting steel discussed in this chapter, Chapter 4 will discuss the program implementation details.



## **CHAPTER 4**

### **PRECISE PROGRAM**

This chapter provides the reader with background on artificial intelligence and describes the general problem solving strategy for crane positioning using artificial intelligence techniques. The methodology for solving this problem is given. Production rule systems are defined in the context of the methodology presented. The selection of Prolog as a programming language to develop a production rule system is explained and the reader is provided a basic introduction to the elements of Prolog using a simple program. A description of the PRECISE program and the specific program modules is given. The chapter concludes with an example of how the program procedure is applied to a simple building.

#### **4.1 Artificial Intelligence Background**

Artificial intelligence has been defined as the study of the way computers can be made to perform cognitive tasks that at present are more readily performed by humans (Ralston, 1988). It attempts to solve problems in an associative manner, operating much as the human brain functions. The result is what is termed a "satisficing" solution, similar to what a human expert would produce (Simon, 1981). Artificial intelligence does not necessarily attempt to find the perfect solution or use the most efficient mechanism for solving the problem. Instead, it uses symbolic processing and establishes logical relationships instead of computational solutions to problems. Artificial intelligence has been successfully implemented when

the knowledge domain is limited to a specific area of human expertise (Albert, 1988).

As discussed in Chapter 3, the knowledge domain for the PRECISE program is limited to using mobile cranes for erecting single story steel structures. The search for all possible crane positions using a computational approach is impractical. However, by using the relational approach discussed in Section 3.3, artificial intelligence techniques can be utilized to develop rules which can determine the representative crane positions and evaluate the crane productivity. Rules can be used to limit the search space for solutions and point to the most promising solution to combinatorially explosive problems. These rules are called heuristics or rules of thumb.

Rules can also be used to govern sequences of actions when developing plans. Artificial intelligence techniques are well suited to developing a tentative course of action, which can be evaluated for consistency with subgoals of the program. If inconsistencies are found, backtracking can be implemented and alternative course of actions can be considered.

## **4.2 Strategy for Crane Positioning Using Artificial Intelligence Techniques**

When humans attempt to solve the problem of crane positioning using cognitive methods, they locate the crane at the intersection of crane load radii, with origins at the corners of the building. Construction planners use the first "acceptable solution they think of. This may not result in selecting the optimum envelopes if the crane swing angle is large, or the optimum

combination of passes if the crane cannot reach across the building as was discussed in sections 3.5.1 and 3.5.2.

The solution to the crane positioning problem requires the development of a knowledge representation for the building structure and the crane and a search strategy for determining the crane positions. Knowledge representation for the building consists of individual database entries for each of the basic structural components-- columns, beams and purlins. Each member is represented with a unique identification number and location coordinates. Unique identification of each members allows for the future addition of attributes such as weight and connection type. This will permit the user to obtain information on the total weight of steel erected from each crane position and can be used with scheduling of shipments.

Logical relationships between members can be established by applying rules. An example rule might be that a column is connected to a beam if the x, y, and z coordinates of the column and beam are the same. Rules can also be established for the sequence of erection. For example, when erecting steel, a beam is unable to support itself. The rule is " a beam can be erected if the columns to which it connects have been erected."

If the building must be subdivided, the search strategy requires the generation of a list of structural members which can be erected from one crane position corresponding to each subdivision. The rule for list membership is that the member must be within the crane envelope and setting the member must not cause the crane boom to interfere with previously erected members. Each combination of crane positions represents a state and the members which can be erected represent a partial solution to the goal of erecting all of the members. The solution to the

problem becomes a state space search to determine which combination will yield the highest productivity. Since pass widths for the initial crane positions determine the crane pass widths for the entire structure, production rates for the representative crane positions can be used to predict productivity all of the crane locations in that pass width. Because the envelope for the first crane position includes the endwall, which includes an extra row of columns and beams, an artificial envelope is created which excludes the first row and begins with the center of first row of purlins. An example is illustrated in Figure 4.9 in section 4.8.

### **4.3 Methodology**

The methodology for solving this problem is as follows:

- (1) Input geometric data on building and crane
- (2) Determine the maximum operating width for the crane and the minimum number of passes required by the crane to erect the building
- (3) Determine all possibilities for dividing the building by determining the combinations of crane pass widths for the minimum number of crane passes.
- (4) Find one crane location for each of the passes
- (5) Establish one representative crane envelope for each of the crane passes. The number of members within these envelopes is used to project the productivity for the combination of crane passes.
- (6) Determine which members can be erected within each crane envelope.
- (7) Check that there is no interference between the crane boom and the row of beams closest to the crane when setting purlins. If there is an

interference, repeat the check for interferences on the next row of beams closest to the crane and remove that row. Continue this process until there is no longer an interference.

- (8) Determine the average productivity for each combination of crane passes.
- (9) Find the combination of passes with the best productivity.
- (10) Increment the minimum number of passes by 1 ( $\text{NextP} = P + 1$ ).
- (11) Repeat steps 3-9 for the new minimum of passes ( $\text{NextP}$ ).
- (12) Compare the pass combination with the best productivity for  $\text{NextP}$  passes and  $\text{PrevP}$  ( $\text{PrevP} = P$ ) passes. If the best average productivity for  $\text{NextP}$  passes is greater than the best average productivity for  $P$  passes, then update  $\text{NextP}$  and  $\text{PrevP}$ , by incrementing each of them by 1. Repeat steps 3-8 until the best average productivity for  $\text{NextP}$  passes is less than for  $\text{PrevP}$  passes.
- (13) Upon finding the pass combination with the best productivity, find all the crane locations and crane envelopes in each pass beginning at the end of the building. Use a counter to determine the number of erection envelopes required and report this information and the members within each erection envelope to the user.

#### 4.4 Production Rules

The PRECISE program is a production rule system. Production rules are condition-action rules or situation-action rules. They are used to establish relationships between data and define consequent actions the system should take. (Jackson, 1986).

Production rules consist of three basic components which are used for problem solving:

- (1) A global database or working memory which holds data, goals and intermediate results. This is the symbolic representation for each of the objects in the state space.
- (2) The operators or production rules which is the rule set which transforms the symbolic encoding of objects in order to provide a systematic method for searching the state space.
- (3) The control strategy which determines how and when rules are applied in an effort to produce the desired state as quickly as possible (Pearl,1984).

Other characteristics of production systems are (Kumara,1989):

- (1) The global database can be accessed by all rules
- (2) Rules do not call other rules
- (3) Rules are in modules

In this program, the global database is the representation of the given building structure. The production rules are the rules for locating the crane, creating the crane erection envelopes, and sequencing the erection of the structural steel. The control strategy consists of generating all the possible crane pass combinations and evaluating a representative envelope for each crane pass to determine the most productive combination of crane passes.

#### 4.5 Selection of Prolog

Prolog was selected as the programming language because of its applicability to artificial intelligence. Prolog, short for Programming Logic, is a language that solves problems involving objects and their relationships through the application of rules. The Prolog approach is a declarative approach to describe known facts and relationships about a problem rather than a procedural approach to prescribe the solution by a series of steps (Clocksin and Mellish, 1987). Declarative knowledge is a scheme for representing knowledge as facts with limited information. Procedural knowledge emphasizes the representation of knowledge using dynamic rules which describe procedures for using knowledge (Ralston, 1988).

The use of Prolog for solving a problem of this type is justified for the following reasons (Rowe, 1988):

- (1) Prolog syntax and semantics provide an excellent means for representing facts and predicates using formal logic.
- (2) Prolog provides automatic backtracking, simplifying search techniques
- (3) Prolog supports multidirectional reasoning, in which arguments to a procedure can freely be designated inputs and outputs in different ways in different procedure calls, so that the same procedure definition can be used for many different kinds of reasoning

Prolog uses a dynamic database to assert or retract new facts which can be inferred from the application of rules. This feature, used in conjunction with backtracking, allows incorrect decisions to be corrected in light of new information and is very important when planning.

In summary, structural steel erection lends itself to Prolog because:

(1) the connections between members can be represented as logical relationships, (2) the applicability of automatic backtracking, when searching for the best combination of crane positions, and (3) the backtracking and dynamic database features are useful when considering interference problems. The automatic backtracking feature of Prolog makes it more efficient for the programmer than LISP, where the programmer must write his own backtracking schemes.

#### 4.6 Prolog Description

Prolog computer programs consist of: (1) facts about objects and their relationships, (2) rules about objects and their relationships, and (3) questions about objects and their relationships. Figure 4.1 illustrates a simple Prolog program which establishes beam-column connection relationships for a simple structure, given facts about the geometry of each of the beams and columns.

Prolog can use simple predicates called **facts** to establish relationships about objects. The example program stores facts about columns and beams in a database. For example, the predicate "column(c1,0,0)." represents the fact that c1 is the designation for a column with x-coordinate (0) and y-coordinate (0). Similarly, the predicate beam(b1,0,0,10,0) represents the fact that the beam designated b1 has  $x_1, y_1$  coordinates (0,0), and  $x_2, y_2$  coordinates (10,0).



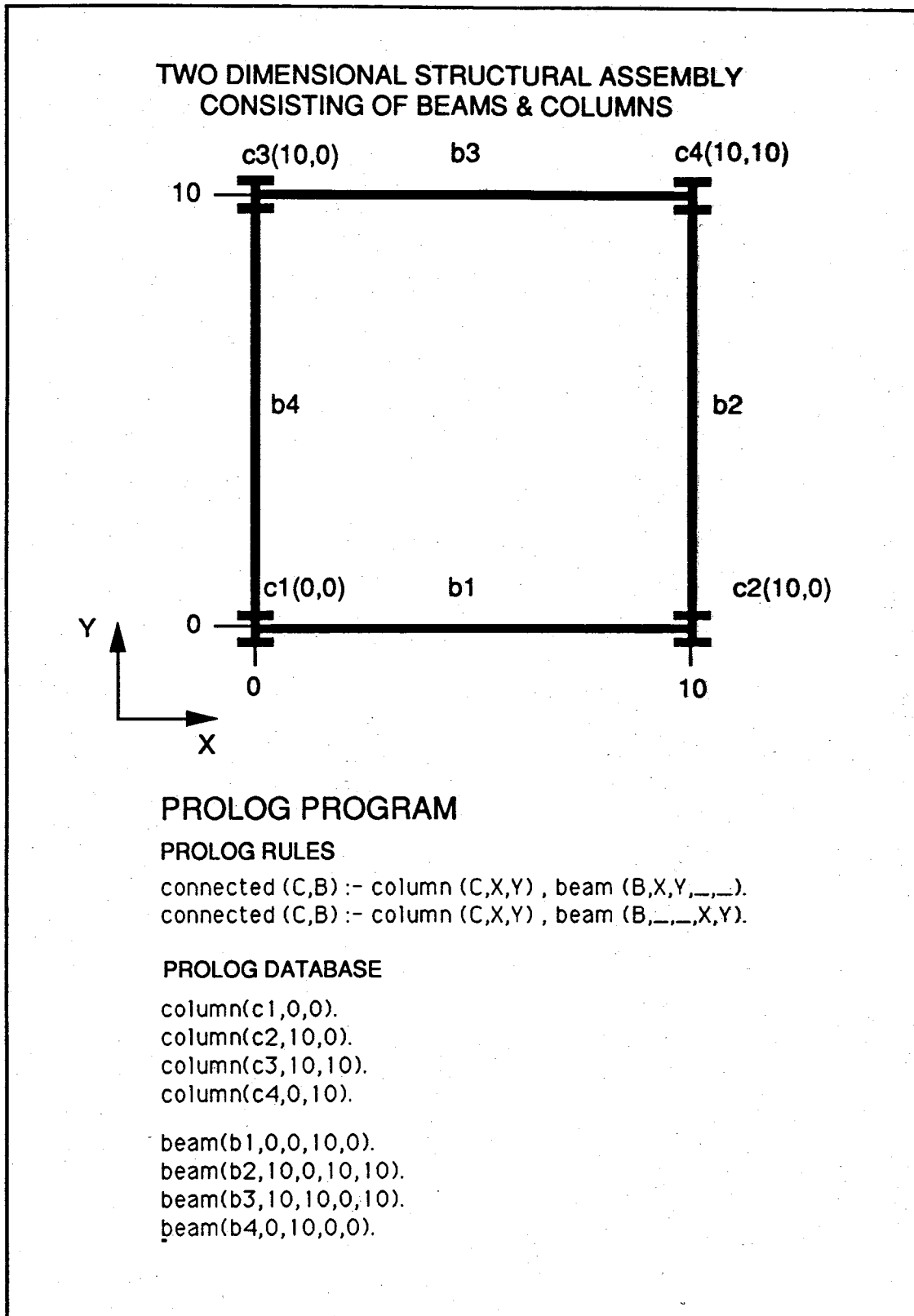

Figure 4.1 Sample Prolog Program for Steel Connections

Prolog performs a task in response to **questions** from the user. For example given the fact above, if the user poses the query "?column(c1,0,0)", Prolog will search the database for that fact and respond "yes."

The user can also use **variables** to obtain information about facts. Variables begin with capital letters. The question, what are the coordinates of beam b2, can be posed as "?beam(b2,X1,Y1,X2,Y2).", where X1, Y1, X2, and Y2 are variables. Prolog uses a process called unification to bind values to variables. For this question Prolog would search the database for the beam designated b2 and bind the following values to the variables; X1 = 10, Y1= 0, X2 = 10, Y2 = 0.

**Rules** are general statements about objects and relationships. A rule consists of a head and body. A rule (the head) can be considered to be true, if the facts (subgoals) pertaining to that rule can be established as true. The body of a rule is the facts or subgoals. For example, the rule that a beam and column are connected is that the (x,y) coordinates of the column must be the same as the (x<sub>1</sub>,y<sub>1</sub>) or (x<sub>2</sub>,y<sub>2</sub>) coordinates of the beam. In Prolog, this will be written as two rules:

(1) connected(C,B):-col(C,X,Y),beam(B,X,Y,\_,\_).

(2) connected(C,B):-col(C,X,Y),beam(B,\_,\_,X,Y).

This example will detail the steps in satisfying the first rule. The head of the rule, "connected(C,B) will be true, if in searching the database a column can be found which has the same (x,y) coordinates as the (x<sub>1</sub>,y<sub>1</sub>) coordinates of a beam. If a goal cannot be satisfied because a subgoal fails, Prolog uses a procedure called **backtracking**. Backtracking consists of reviewing what has been done and attempting to find an alternate way of satisfying that goal. Backtracking is also employed to find all solutions to a goal.

In the example program, if the question "?connected(c3,B)" is posed to the program, Prolog will first match "connected(c3,B)" with the head of the first rule "connected(C,B)", binding "c3" to the variable C. Next Prolog will attempt to satisfy the first subgoal in the body of the rule, "column(c3,X,Y), by attempting to match the first column in the database. This will fail, since the first column in the database is "c1", and backtracking will be initiated. The sequence of searching for matches and backtracking is illustrated in Figure 4.2. The first subgoal succeeds when "c3" matches the third column entry in the database, and X is bound to (10) and Y is bound to (10). The second subgoal searches for a beam with (x<sub>1</sub>,y<sub>1</sub>) coordinates (10,10). Backtracking is utilized until the subgoal is satisfied and B is now bound to "b3". Since both subgoals are satisfied, the head of the rule succeeds, and Prolog program returns the solution "B = b3".

Prolog will attempt to find other solutions, by backtracking and checking if any more beams have (x<sub>1</sub>,y<sub>1</sub>) coordinates equal to (10,10). When this fails, backtracking moves back to the first subgoal, which will also fail because there are no more columns designated "c3" in the database.

After satisfying the first rule, Prolog will backtrack and attempt to satisfy the second rule. A similar search and backtracking process to that used in satisfying the first rule will bind "c3" to the variable C and find a match for "c3" in the database. The second subgoal is satisfied when a beam with (x<sub>2</sub>,y<sub>2</sub>) coordinates equal to (10,10) is found in the database. When this subgoal is satisfied the variable B is bound to "b2", and Prolog returns the second solution, "B = b3".

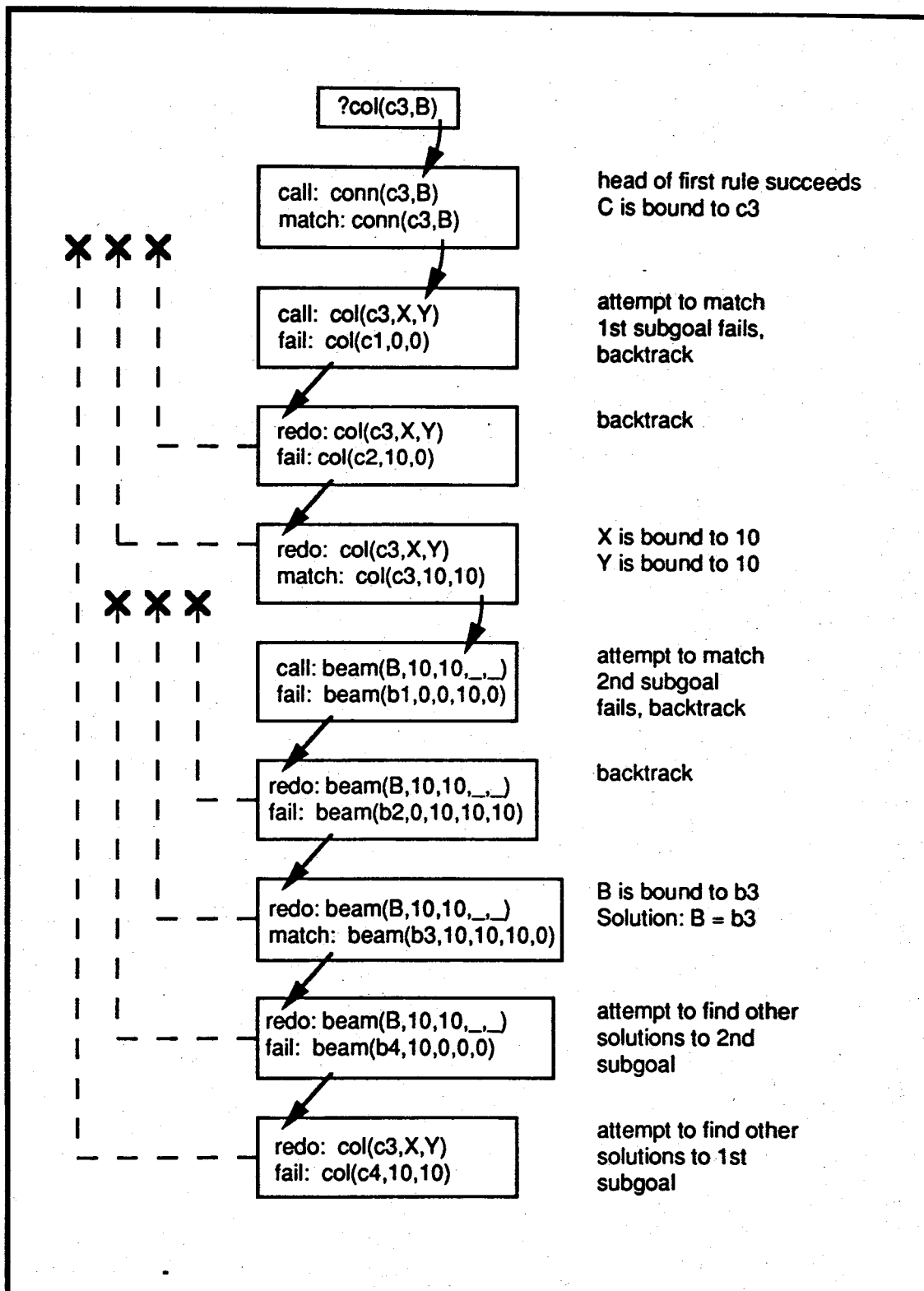

Figure 4.2 Matching and Backtracking Process for Example Prolog Program for Steel Connections

#### 4.7 PRECISE Program Description

The program demonstrates a method for finding crane positions which allow the crane to erect the greatest number of structural members for each position. The program identifies which members can be set from each position and checks for interferences with previously erected members.

This is accomplished by: (1) the application of artificial intelligence search techniques for solving the combinatorially explosive problem of determining the different crane pass widths which are encountered in steel erection, and (2) the utilization of dynamic databases for revising decisions regarding the erection sequence and crane position based on updated knowledge of crane boom interferences with previously erected members.

The approach to this problem (as defined in section 4.3) is to determine the minimum number of crane passes required to erect the building and all of the combinations of crane pass widths. The best combination of pass widths must be determined. For each combination, a representative crane position is found for each crane pass. The number of members which can be erected from each position is calculated to determine an average productivity for the entire pass combination. The pass combination with the best average productivity is found.

The minimum number of crane passes may not yield a pass combination with the highest average productivity. The best average productivity may increase with the number of passes, reaching a maximum and then falling off. For this reason, it is necessary to compare the average productivity for the minimum number of passes ( $P$ ) with the average productivity for  $(P + 1)$  passes. If the productivity for  $(P + 1)$  passes is greater

than for (P) passes, it is necessary to update (P + 1) and check the productivity for (P + 2) passes. This updating process must be repeated until the average productivity begins to fall off.

After finding the crane pass combination with the highest productivity, the program finds all of the crane positions in each pass. It also lists the members that can be erected from each crane position, taking into account the rules for erection sequencing and considering boom interferences. The major rules in the program are discussed in the following sections with figures of the program modules which illustrate the program architecture.

#### **4.7.1 Check Productivity**

The module "check\_productivity" is the control strategy for the PRECISE program (See Figure 4.3). As the number of crane passes increases above the minimum number (P), the average productivity for the combinations will usually decrease for (P + 1) passes. The exception to this rule is if the crane envelope is wide as was discussed in Sec. 3.5.2. In this case the productivity increases for (P + 1) passes before falling off for (P + 2) passes. The program uses this to control the search for pass combinations.

Beginning with the minimum number of passes (P), all of the pass combinations are determined. The pass combination with the best average productivity is determined. This is asserted in the dynamic database as "best\_avg(PREV)". Next all of the pass combinations for (P + 1) passes is determined. The pass combination with the best average productivity is asserted in the dynamic database as "best\_avg(NEXT)". These average productivities are compared, and if "best\_avg(PREV)" is greater than

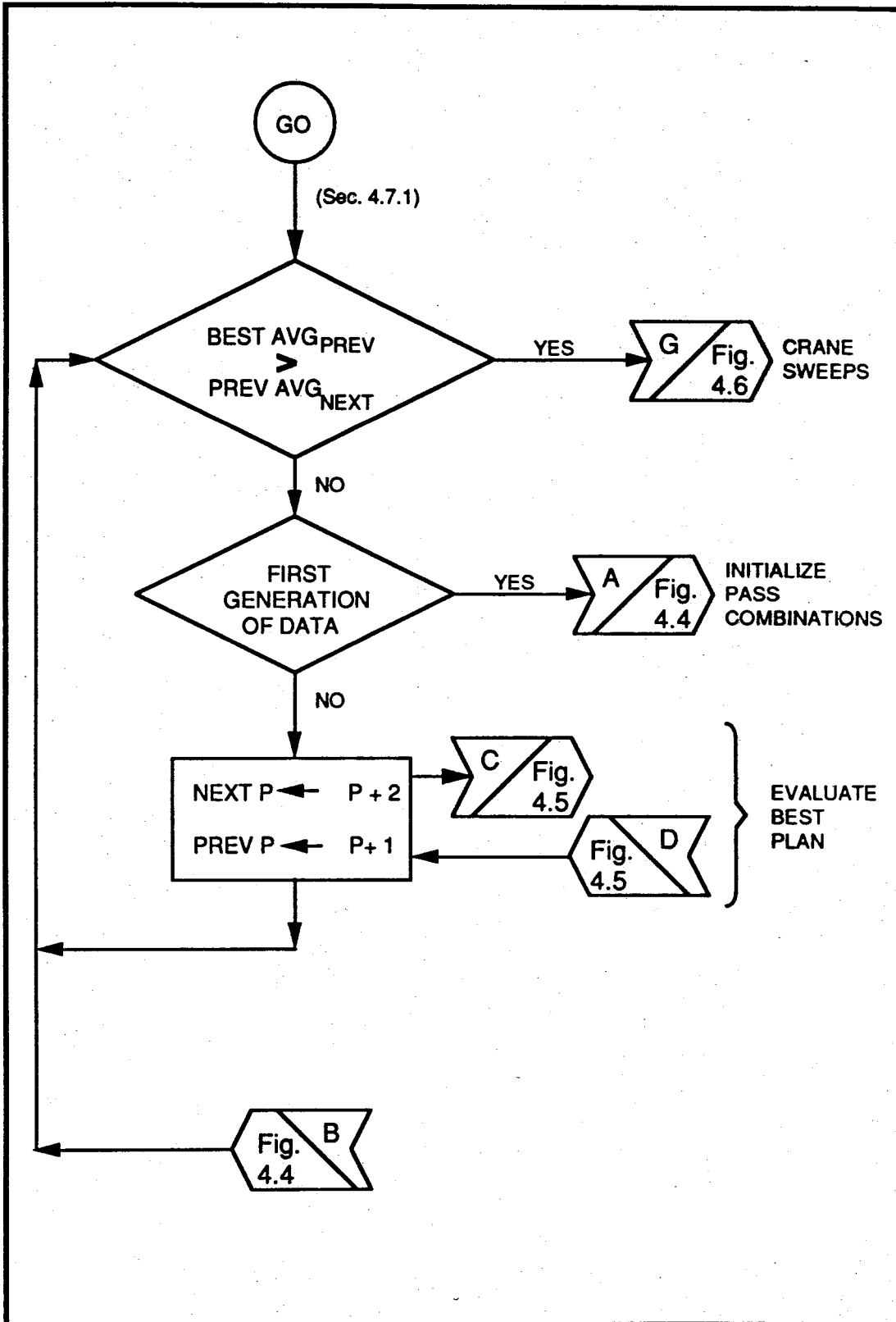

Figure 4.3 Check Productivity Program Module

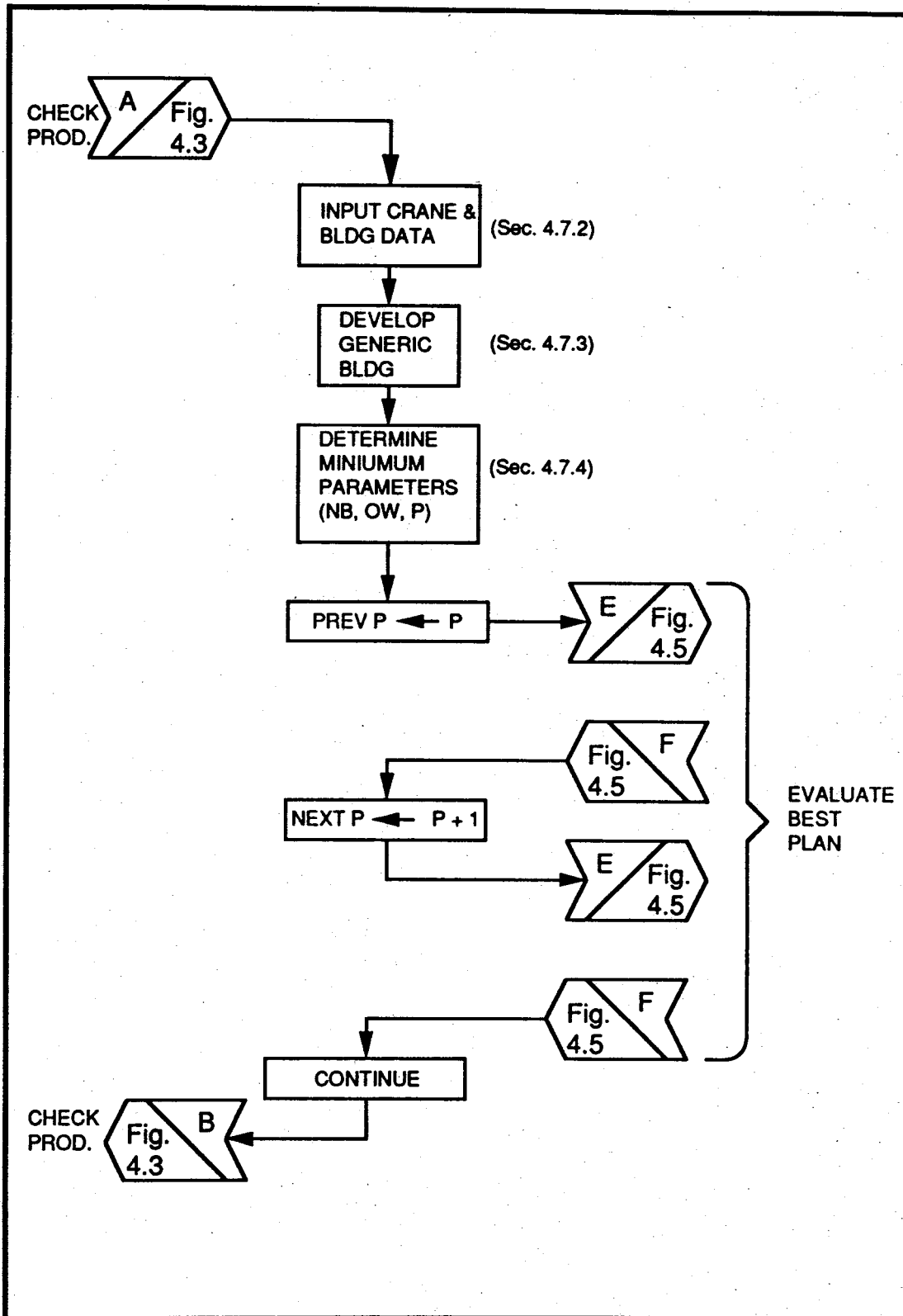

Figure 4.4 Initialize Pass Combinations Program Module



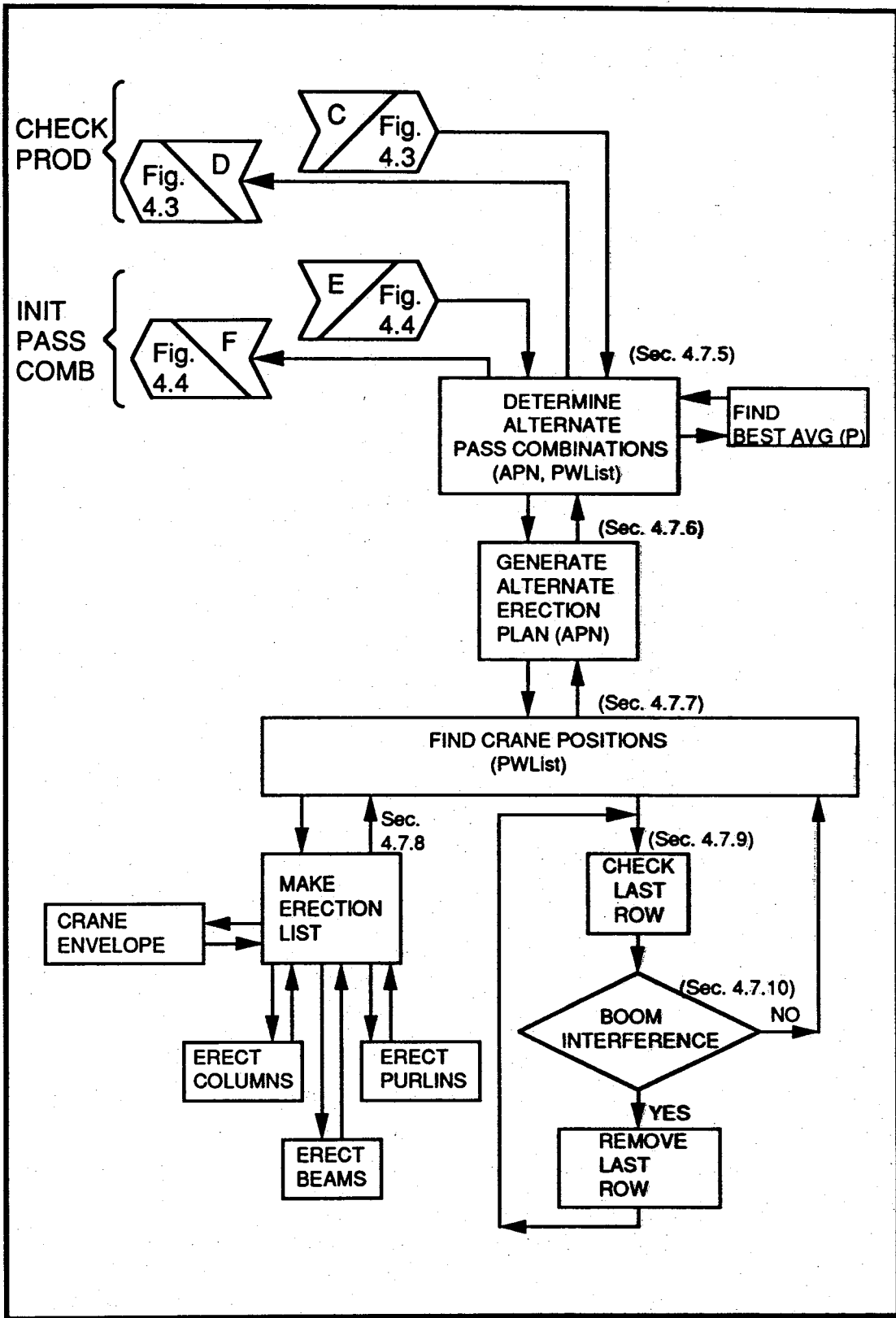

Figure 4.5 Evaluate Best Plan Program Module

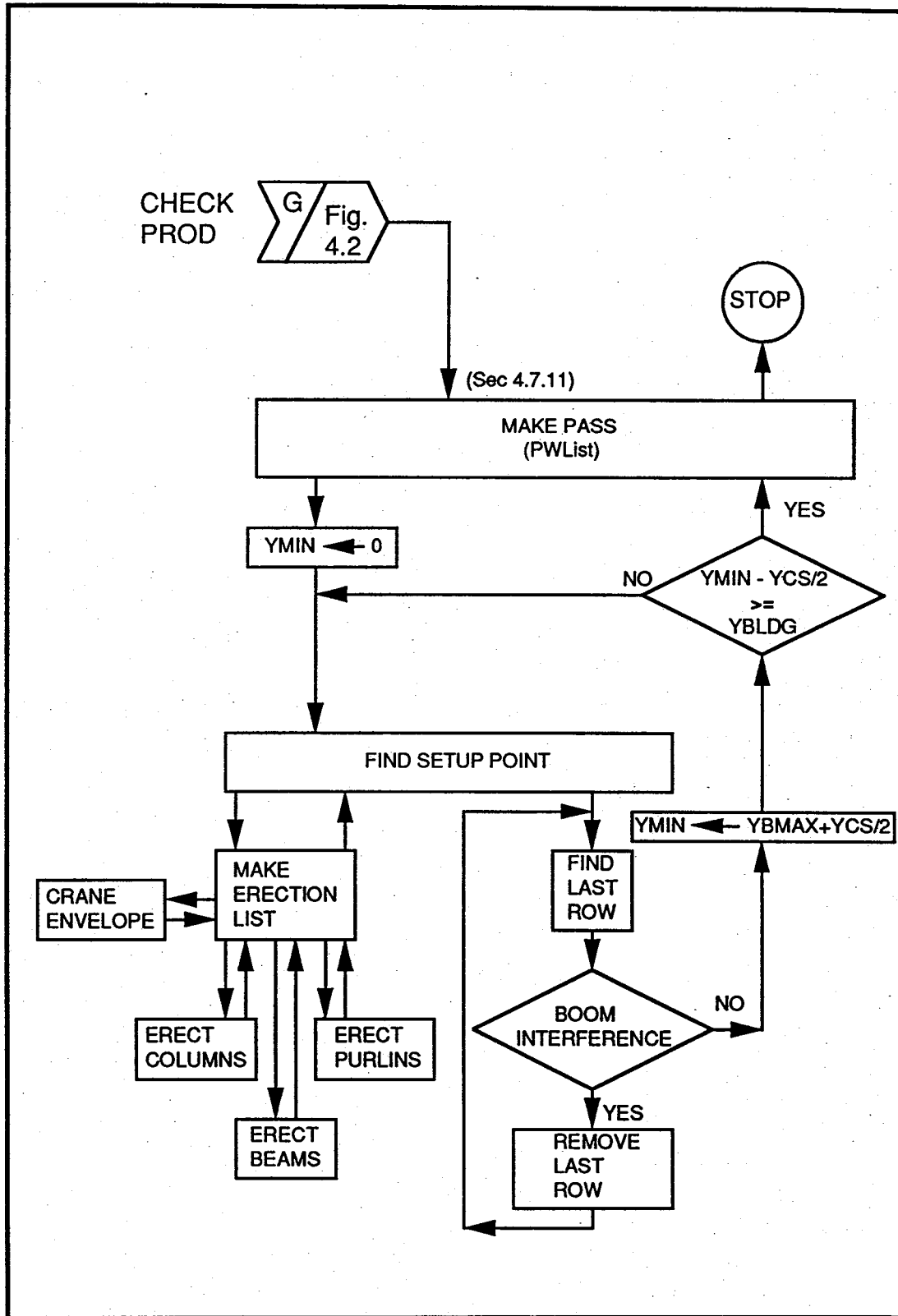

Figure 4.6 Crane Sweeps Module

"best\_avg(NEXT)", there is no need to generate any more combinations and the program can proceed with finding the crane positions and erection sequencing corresponding to the pass width combinations for "best\_avg(PREV)".

If "best\_avg(NEXT)" is greater than "best\_avg(PREV)", it is necessary to update the number of passes. In this case the "best\_avg" for  $(P + 1)$  passes now becomes "best\_avg(PREV)" and the best average productivity for  $(P + 2)$  passes becomes "best\_avg(NEXT)". This updating cycle of increasing the number of passes and finding the best average for all of the combinations continues until "best\_avg(PREV)" is greater than "best\_avg(NEXT)".

There are three "check\_productivity" rules. The first rule checks if "best\_avg(PREV)" is greater than "best\_avg(NEXT)" and upon succeeding, finds the crane positions required for erection of the building. This rule always fails on the first test, because no data has been input and no averages have been calculated. Control passes to the second rule. The second rule checks if any data has been previously input. This rule succeeds if no data has been input and proceeds to initialize the pass combinations for  $P$  and  $(P + 1)$  passes (See Fig. 4.4). After determining the best productivity averages, it calls the first "check\_productivity" rule. If the first two rules fail in succession, the third rule updates "best\_avg(PREV)" for  $(P + 1)$  passes and "best\_avg(NEXT)" for  $(P + 2)$  passes. This rule recursively calls the first rule. If the first rule fails, the second one will also fail because now data has been entered. Averages for  $(P + 2)$  and  $(P + 3)$  passes become "best\_avg(PREV)" and "best\_avg(NEXT)". This recursive process continues until the first rule succeeds.

#### **4.7.2 Input Crane and Building Data**

The user is prompted for information regarding the building structure and the crane.

The information required by the program is:

- (1) M - Number of columns in X-direction
- (2) XCS - Column spacing in X-direction
- (3) N - Number of columns in Y-direction
- (4) YCS - Column spacing in Y-direction
- (5) ZB - Beam elevation
- (6) R - Crane operating radius
- (7) BL - Crane boom length
- (8) SB - Crane set back
- (9) BPH - Boom Pivot Height

#### **4.7.3 Develop Generic Building**

The generic building is the knowledge representation of the building structure. The generic building is developed by generating a grid of M rows spaced at a distance XCS apart in the X-direction and N lines spaced at a distance YCS apart in the Y-direction. For each row and line intersection a column with corresponding (x,y) coordinates is asserted in the dynamic database using forced backtracking. Column rows in the Y-direction are assigned letter designations beginning with A,B,C,etc. Column lines in the X direction are assigned number designations beginning with 1, 2, 3, etc.

Each column is assigned a unique identification corresponding to the row-line intersection beginning with "A1."

Beams run across the building in the X-direction and are asserted in the dynamic data base with coordinates  $(x_1, y_1)$  and  $(x_2, y_2)$ . The coordinates correspond to columns which are adjacent in the X-direction. Each beam is assigned a unique identification number beginning with "b1" and is numbered in sequence, "b1", "b2", "b3", etc.

Purlins run across the building in the Y-direction and are asserted in the dynamic data base with coordinates  $(x_1, y_1)$  and  $(x_2, y_2)$ . The coordinates correspond to columns which are adjacent in the X-direction. Each purlin is assigned a unique identification number beginning with "p1" and is numbered in sequence, "p1", "p2", "p3", etc..

#### 4.7.4 Determine Parameters

The first step in determining the erection sequence is to determine the operating width of the crane and the minimum number of passes required by the crane to erect the steel. The maximum operating width (OW) is the number of bays the crane can span. This must account for the crane setback. The crane set back is the minimum distance the crane must be set behind a row of columns in order to set them, without the crane boom or crane undercarriage interfering with any of the structural members in that row. This dimension will generally be between 10 and 20 ft. The maximum operating width for the crane can be expressed as:

$$OW = 2 \times \frac{\sqrt{R^2 - SB^2}}{YCS}$$

If this number is not an integer, it must be rounded down to the next lowest integer.

The next step is to determine the minimum number of passes required by the crane to erect the building. This is expressed as:

$$P = \frac{NB}{OW}$$

where, P = number of passes required

NB = building width expressed as number of bays. A bay is the distance between two adjacent columns. The number of bays in the X direction is equal to M - 1 or the number of columns minus one

OW = maximum crane operating width in bays

P is an integer and is rounded up. If the operating width (OW) is greater than or equal to the building width (NB), the minimum number of crane passes required to erect the steel is one.

#### 4.7.5 Determine Alternate Pass Combinations

If the crane operating width is equal to the number of bays, only one pass is required by the crane to erect the building. However, if the operating width of the crane is less than the number of bays, it is necessary to generate all the various crane pass combinations as was discussed in Section 3.5.2. The formula developed to find the pass width combination is:

$$\sum_{i=1}^p PW_i = NB \quad PW_i \leq OW$$

where PW = Pass width of the crane

NB = Number of bays

P = Number of passes required by the crane to erect the building

For example, the building in Fig. 3.4 is 10 bays wide, the maximum operating width for the crane is 3 passes, and the minimum number of crane passes is 4. There are two combinations of crane pass widths which are [1,3,3,3] bays and [2,2,3,3] bays.

Determination of the possible combinations is accomplished by using a depth-first search. Each possible value for  $PW_j$  is placed in a list of length P, and if the sum of the list is equal to NB, an alternate path list of crane pass width combinations and a corresponding alternate path index (APN) are asserted to the dynamic database. The program utilizes the built in power of Prolog to generate different values for  $PW_j$  as it backtracks through the possible values for  $PW_j$ .

#### 4.7.6 Generate Alternate Erection Plans

For a given number of crane passes (P) and corresponding to each of the alternate path combinations indexed by APN, an erection plan is determined. Each of the crane positions must be found, the members which can be erected from each position must be determined, and the average productivity rate must be calculated. This productivity rate is found by summing the number of structural members that can be erected by the crane from the first position in each pass and dividing by the number of passes.

$$PROD = \frac{TOT}{P}$$

To determine the average, the rule to find each crane position is invoked using the list of pass widths as the argument. Forced backtracking is used to determine a productivity rate for each of the pass combinations.

#### 4.7.7 Find Crane Positions

Find Crane Positions is a recursive rule using the list of crane pass widths (PWList) to find the corresponding crane positions which are indexed by "I" from 1 to P. Each position is the center of the pass width and is located at the intersection of two crane radii with origins at the center of the outside purlins in each pass width. The formula for finding the local crane positions is:

$$X\text{-Coord}_i = \left[ \frac{PW_i}{2} + \sum_{j=1}^{i-1} PW_j \right] \times XCS$$

$$Y\text{-Coord}_i = \frac{YCS}{2} + \sqrt{R^2 - \left[ \frac{PW_i}{2} \times XCS \right]^2}$$

where: PW = pass width of the crane

R = crane radius

XCS = distance between columns in X direction

For each of the alternate pass combination numbers(APN) and for each crane position "I", the structural members which are in the crane erection envelope are determined by firing the "erection\_list" rule and the "ck\_last\_row" rule. The total number of columns, beams, and purlins which can be erected from each position are counted and stored as "NoCol",



"NoBeams", and "NoPurlins," respectively. These are used to calculate the total number of members which can be erected from each crane position as:

$$\text{TOT} = \text{NoCol} + \text{NoBeams} + \text{NoPurlins}$$

#### 4.7.8 Make Erection List

For each crane position an operating envelope is determined. This envelope is defined by minimum and maximum values for X and Y, where:

$$\begin{aligned} X_{\text{MIN}i} &= -0.001, \text{ if } i=1 \\ X_{\text{MIN}i} &= \sum_{j=1}^{i-1} PW_j \times XCS, \text{ if } i > 1 \\ X_{\text{MAX}i} &= \sum_{j=1}^i PW_j \times XCS \\ Y_{\text{MIN}i} &= \frac{YCS}{2} - 0.001 \end{aligned}$$

$$Y_{\text{MAX}i} = Y_{\text{Coord}i} - SB$$

The envelope for the first crane position includes an extra row of columns and beams in the endwall and is not indicative of the productivity for the the other envelopes in the crane pass. For this reason an artificial envelope is created, which does not include the endwall, but begins with the center of the purlins between the first and second rows of beams. Once the crane envelope is determined, the columns, beams and purlins which are within the limits of the erection envelope can be asserted in the local erection list database.

#### 4.7.9 Check Last Row

Check last row is a recursive rule that determines the Y-coordinate of the row of beams closest to the crane and calls the rule, "ck\_boom\_interference" to determine if in the process of setting purlins the boom interferes with any of the beams. This rule calls itself until the rule for checking interferences fails.

#### 4.7.10 Check Boom Interference

This rule calculates the crane boom angle ( $\Theta$ ) required to set a purlin based on the boom pivot height, the horizontal crane swing angle ( $\Phi$ ), and the X-Y coordinate of the purlin center of gravity. It also calculates the interference angle ( $\Theta_i$ ) made at the point where the vertical plane of the boom crosses the beam. If the boom angle is less than the interference angle for any of the purlins in a row, all of the purlins in that row must be removed. Additionally, the columns and beams in the row between the row between the crane and purlins must also be removed.

#### 4.7.11 Crane Sweeps

Corresponding to "best\_avg" is a list of pass widths [PWList] for the crane. This module finds the crane positions for each pass in the [PWList] and finds all members which are within each crane envelope. Using the "make\_erection\_list" rule, members are removed from the "building" data base and placed in the "erected" data base as they are erected. This serves

two purposes: (1) It reduces the size of the "building" database which must be searched when finding members in the erection envelopes, (2) It is used to establish the connected relationship. For example, purlins cannot be erected, until the beams to which they connect have been erected.

The "make\_pass" rule is a recursive rule which uses the list of pass widths to find all the crane setup points in each pass. Similar to the find crane position rule described in section 4.6.8, the find setup points rule finds all of the members which can be erected from each crane setup point. This is a recursive rule which updates the new value of YMIN for the erection envelope:

$$YMIN \leftarrow YBMAX + \left( \frac{YCS}{2} \right)$$

where YBMAX is the maximum Y dimension of the beams in the erection envelope. When the value for YMIN exceeds the maximum Y dimension for any of the beams in the building, the crane pass is complete.

#### 4.8 Example Building Solution

The general procedure for analyzing a simple building is outline below using the building in Figure 4.7.

- (1) Input the geometric data
  - (a) M = 6 (No. of columns in X-direction)
  - (b) XCS = 24' (Column spacing in X-direction)
  - (c) N = 5 (Number of columns in Y-direction)
  - (d) YCS = 20' (Column spacing in Y-direction)
  - (e) ZB = 25' (Beam elevation)
  - (f) R = 55' (Crane operating radius)

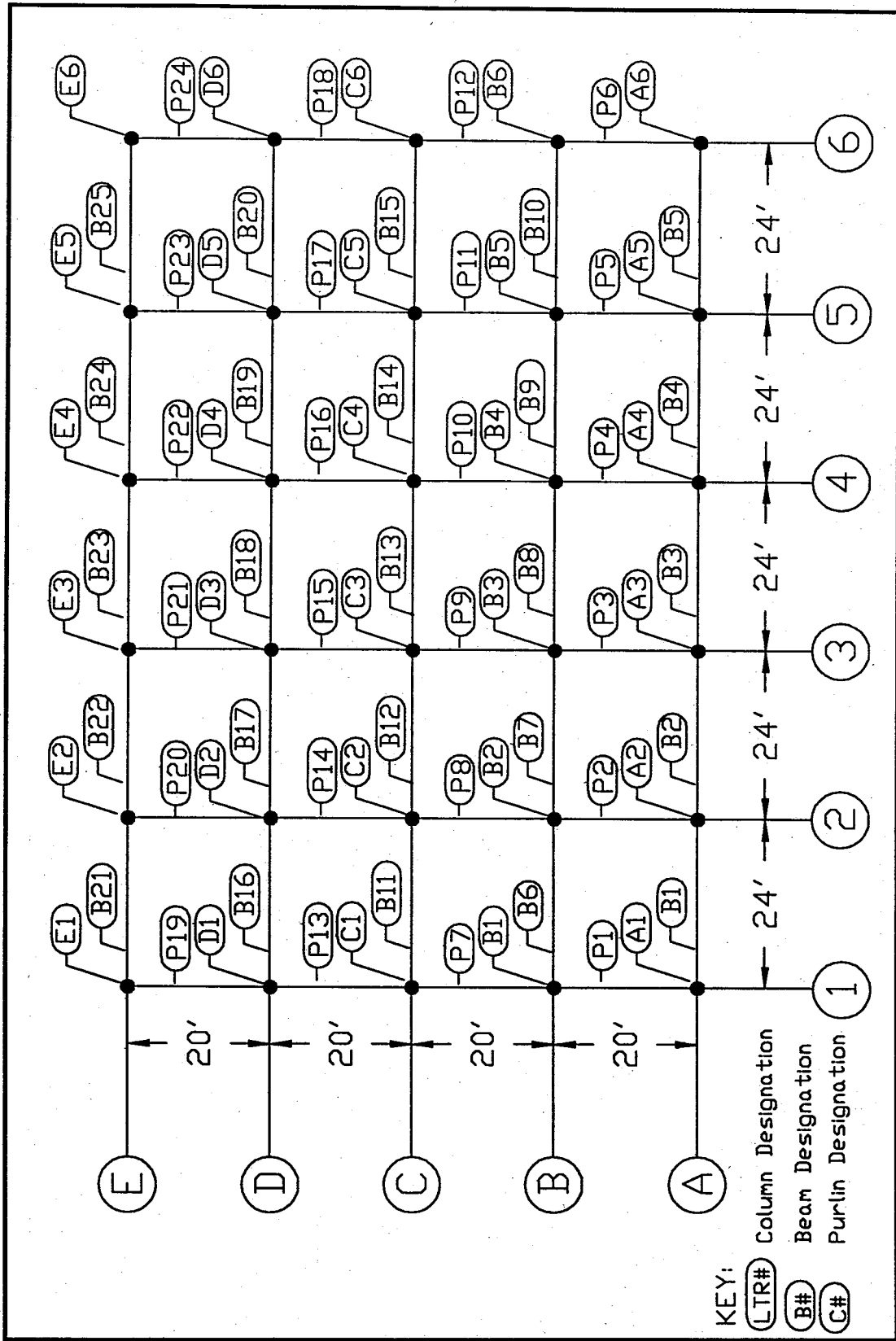

Figure 4.7 Example Building

- (g) BL = 65' (Crane boom length)
- (h) SB = 6' (Crane set back)
- (i) BPH = 10' (Boom Pivot Height)

- (2) Determine the maximum operating width of the crane:

$$OW = 2 \times \frac{\sqrt{R^2 - SB^2}}{YCS}$$

$$OW = 2 \times \frac{\sqrt{55^2 - 6^2}}{24}$$

$$OW = 4.55 \text{ bays}$$

The maximum crane operating width is rounded down to 4 bays and the building is 5 bays wide. Therefore, the minimum number of passes required by the crane to erect the building is  $P = 2$ .

- (3) Determine all the possibilities for dividing the building:

The combinations for dividing the building, using 2 passes where the sum of the pass widths must equal 5 bays are [1,4] bays and [2,3] bays.

- (4) Find the crane locations for representative crane envelopes in each pass:

Figure 4.8 shows the crane locations for the [2,3] bay crane pass combination. The (x,y) coordinates for the 2 bay pass are (24',59.49') and the 3 bay pass are (84',51.58'). Note the crane location is based on the center of the purlins in the first outside row of each crane pass.

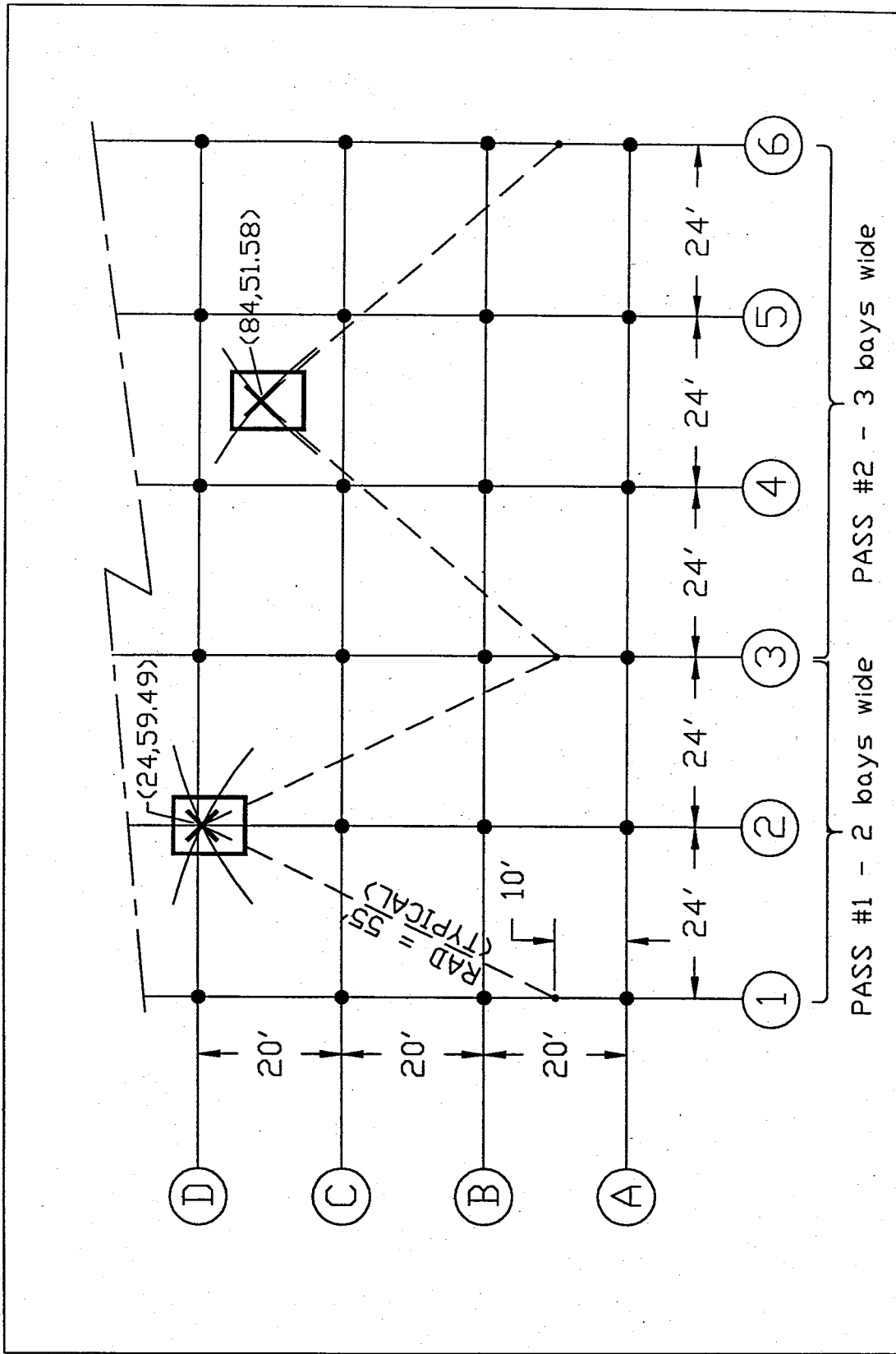

Figure 4.8 Find Crane Position for [2,3] Bay Pass Combination

- (5) Establish one representative crane envelope for each pass. These crane envelopes do not include the endwall, but begins with the center of the first row of purlins for each pass. Using the [2,3] bay crane pass combination as an example, the crane envelope for the 2 bay pass will be:

$$\begin{aligned} XMIN_1 &= -0.001 \\ XMAX_1 &= PW_1 \times XCS = 2 \times 24' = 48' \\ YMIN_1 &= \frac{YCS}{2} - 0.001 = \frac{20'}{2} - 0.001 = 9.999' \end{aligned}$$

$$YMAX_1 = YCoord_1 - SB = 59.49' - 6' = 53.49'$$

The crane envelope for the second crane pass which is 3 bays wide will be:

$$\begin{aligned} XMIN_2 &= (2 \times 24') = 48' \\ XMAX_2 &= (2 + 3) \times 24' = 120' \\ YMIN_2 &= 9.999' \\ YMAX_2 &= YCoord_2 - SB = 51.58' - 6' = 45.58' \end{aligned}$$

- (6) Determine the number of members that can be erected within each crane envelope. For the [2,3] bay crane pass combination shown in Figure 4.9, 16 members can be erected from the first crane position and 18 members can be erected from the second crane position. Similarly, the crane locations and crane envelopes can be determined for the [1,4] bay pass combination using the same steps 4 and 5 above.
- (7) For each crane position in each pass combination a check must be made for boom interferences with the row of beams closest to the crane

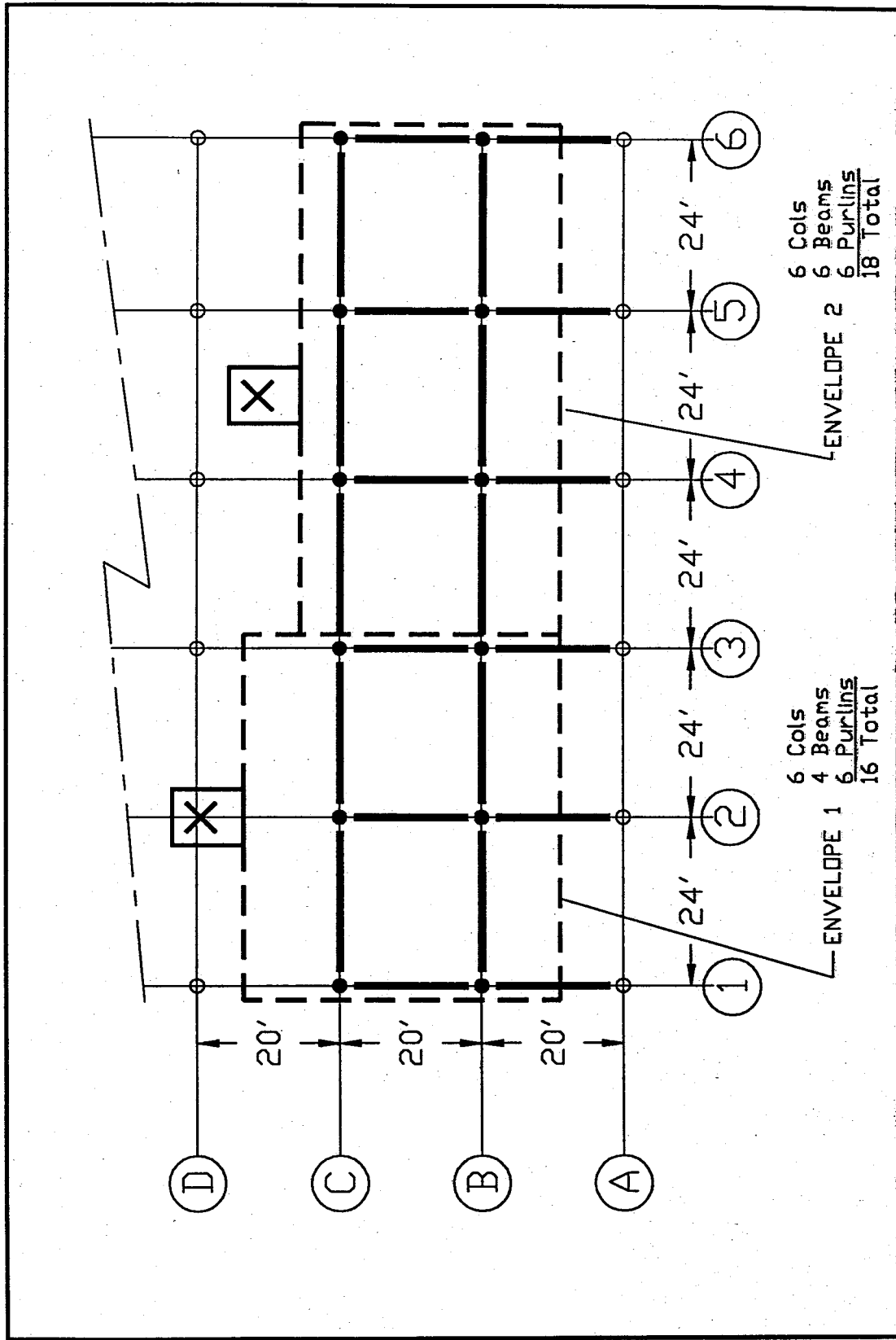

Figure 4.9 Representative Crane Envelopes for [2,3] Bay Pass Combination



using the procedure outlined in section 3.6.3. If an interference is encountered which prevents setting the last row purlins, the row of beams which interfere with the boom and columns are removed.

- (8) Find the combination of passes with the best productivity:

The total number of members that can be erected for the first crane pass combination of [2,3] bays is [16,18] members, where 16 members can be erected from the crane position which is 2 bays wide and 18 members can be erected from the crane position which is 3 bays wide. The average productivity is the total number of members (34) divided by the number of crane passes (2) for an average of 17 members per crane setup.

Similarly, the productivity for the second crane pass combination of [1,4] bays is [10,12] members. The average productivity for the [1,4] bay pass combination is 11 members per crane setup. The [2,3] bay pass combination is the best combination for  $P = 2$  passes.

- (9) Increase the minimum number of passes by 1 from  $P = 2$ , to  $P = 3$ .
- (10) Repeating steps 3 - 9, the combination of 3 passes that adds up to 5 bays are [1,1,3] bays and [1,2,2] bays. After finding the crane locations, the erection envelopes for each of the locations, and removing any members which cause boom interferences, the productivity for each crane position in the [1,1,3] pass combination is [10,6,18] members.

Similarly, the productivity for the [1,2,2] bay pass combination is [10,12,12] members. The average productivity is the total number of members for the three crane positions divided by the number of passes ( $P = 3$ ). The average productivity for each pass combination is 11.33 members. (In cases where the productivity is equal for two pass combinations, the pass combination which divides the building into nearly equal pass widths is used. In this case, [1,2,2] bay combination divides the building more equally than the [1,1,3] bay combination.)

- (11) Compare the productivity for NextP ( $P = 3$ ) and PrevP ( $P = 2$ ) crane passes. The best average productivity for 2 passes is 17 members per crane setup vs. best average productivity for 3 crane passes which is 11.33 members per crane setup. If the building is divided into 4 or more passes the average productivity per crane setup will continue to decline, so the crane pass combination of [2,3] bays can be used to erect the building.
- (12) Beginning at the end of the building, find all of the crane crane locations and crane envelopes required to erect the steel. Begin by finding all of the envelopes required for the 2 bay pass. For each erection envelope find the largest Y value of the beams within the erection envelope. When this value is equal to the length of the building ( $YCS \times (N - 1)$ ), the pass is complete. The crane positions and envelopes for the 3 bay pass are found in a similar manner. Table 4.1 summarizes the information on crane locations and erection envelopes.

Table 4.1 Summary of Crane Locations, Crane Envelopes and Members Erected

SETUP NO	CRANE LOC		CRANE ENVELOPE			YMAX	COLUMNS	MEMBERS ERRECTED			TOTAL
	X	Y	XMIN	XMAX	YMIN			BEAMS	PURLINS		
1	24	49.49	-0.001	48	-0.001	43.49	A1,A2,A3, B1,B2,B3 C1,C2,C3	B1,B2, B6,B7, B11,B12	P1,P2,P3, P7,P8,P9		21
2	24	99.49	-0.001	48	48.999	93.49	D1,D2,D3, E1,E2,E3	B16,B17 B21,B22	P13,P14,P15 P19,P20,P21		16
3	84	41.58	48	120	-0.001	35.58	A4,A5,A6 B4,B5,B6	B3,B4,B5 B8,B9,B10	P4,P5,P6		15
4	84	71.58	48	120	29.99	65.58	C4,C5,C6 D4,D5,D6	B13,B14,B15 B18,B19,B20	P10,P11,P12		18
5	84	111.58	48	120	69.999	105.58	E4,E5,E6	B23,B24,B25	P22,P23,P24		9

After finding all of the crane positions for a given crane to erect a building, it is possible to vary parameters, such as crane radius, to determine the effect on the number of crane setups required to erect a building. Conversely, different building structures can be tested for a specific crane. The results of test runs will be discussed in the next chapter.

#### **4.9 Summary**

This chapter described how artificial intelligence techniques could be used to solve problems in a manner similar to the approach used by humans. It explained how structural steel erection procedures could be incorporated into a production rule system. The selection of Prolog was justified as the programming language and a specific example which applies to structural steel was provided. The program modules and architecture was described, concluding with a specific example.

## CHAPTER 5

### PROGRAM TESTING

This chapter describes several building situations which were analyzed by the PRECISE program. It demonstrates a means of utilizing the data generated by PRECISE to compare the time and costs for different cranes which a contractor might use on a single story steel structure.

#### 5.1 Building Descriptions

Three buildings were chosen to test the PRECISE program. The buildings selected represent medium, large and very large buildings encountered in single story steel construction by the companies interviewed. The data on these test buildings is given in Table 5.1. These buildings are in the size range that the PRECISE program can provide useful information. Small buildings of 6,000 to 20,000 sq.ft. were not analyzed because in many cases only one or two crane setups are required to erect the building.

	Number Columns (X-direction)	Number Columns (Y-direction)	Column Spacing (X-direction)	Column Spacing (Y-direction)	Area (sq. ft.)
BLDG 1	10	12	20	20	39,600
BLDG 2	14	14	40	30	202,800
BLDG 3	14	21	50	40	520,000

Table 5.1 Test Building Data

## 5.2 Crane Descriptions

The cranes selected for the PRECISE program are hydraulic cranes typically used by steel erectors for this type of construction. All cranes can handle approximately 1000 lb. at the maximum radius. The cranes selected were:

- (1) An RO Stinger 175 series which mounts on a truck body. These cranes have the advantage of being very mobile and can easily move from one site to another on the same day. Additionally, the truck body can be used to haul material. This is important when steel erectors typically work in a 75 mile radius of their main office. Because they are mounted on truck bodies, they are relatively expensive to operate and require the same insurance, taxes and permits as trucks. Maintenance is high because they must be maintained for highway conditions. The operator must stand on the truck bed to operate the crane which may affect the efficiency of the crane. This crane has an 87' boom length and operates at a 70' radius.
- (2) A P&H S-20 all terrain crane. This crane can travel on the highway under its own power at speeds up to 47 mph. This crane cannot attain the highway speeds of the RO Stinger, but it does not pay the road use taxes and insurance that are required of a truck mounted crane. These cranes have a lattice jib extension which permits them to operate at an 85' radius with 103' boom length.
- (3) A P&H Century 128 rough terrain crane. These cranes are extremely mobile on a project site, but must be transported between sites by a special haul truck and unloaded. The initial cost is less than an all terrain crane, because they do not require the special suspension of the all

terrain crane. These cranes have a lattice boom extension which permits them to operate at 105' with a 114.5' booomlength.

- (4) A P&H Omega 50 rough terrain crane. This crane is similar to the Century 128, except that assembly and disassembly of the lattice jib and outriggers are required in order to haul this crane. These cranes have a lattice boom extension which permits them to operate at 130' with 140' booomlength.

### 5.3 Cost Analysis Basis

The total costs for steel erection, exclusive of materials are labor and equipment costs. Equipment costs for a project are the rental cost of the equipment or the ownership and operating costs plus the transportation cost to the project. For this analysis rental costs will be used. If the crane is truck-mounted or an all terrain crane, running under its own power, the transportation cost is the cost of the operator plus the hourly crane cost to get the crane to the project. If the crane is a rough terrain crane, the cost of hauling the crane plus any assembly and disassembly must be added to the equipment cost.

The total crane cost for a project is:

$$\text{Total Crane Cost} = \text{Daily Crane Cost} \times \text{Erection Time} + \text{Transport Cost}$$

The total labor cost for a project is:

$$\text{Total Labor Cost} = \text{Daily Labor Cost} \times \text{Erection Time}$$

The time required to complete the project depends on the number of pieces of steel, the productivity for erecting the steel, the time lost each time the crane

moves, and the number of crane moves. The productivity rate is based on the number of pieces that can be set from a single crane position:

$$\text{Erection Time} = \frac{\text{No. Pieces}}{\text{Daily Production}} + \text{Crane Setups} \times \text{Move Time}$$

#### 5.4 Assumptions Used in Cost Analysis

The following assumptions were used in developing the cost analysis:

- (1) Daily equipment costs for the cranes are the monthly rental costs divided by 20. These costs were obtained from a local crane distributor.
- (2) Transportation costs are based on 4 hours total transport time to the project and include assembly and disassembly if required.
- (3) Daily labor costs are based on a five man erection crew (including operator), non-union, working 8-hour days. Hourly labor cost for each person, including wages, fringe benefits, taxes and insurance is assumed to be \$25.00/hr.
- (4) Daily Production rates are based on production estimates of one of the interviewees of 50 to 65 pieces per day for a 10-hour day. These were scaled back to 40 to 52 for an 8-hour day. An average productivity of 45 pieces per day is assumed.
- (5) Crane setups and number of pieces are obtained from the PRECISE program.
- (6) Move time for the crane is 30 minutes. This number will normally range between 15 and 60 minutes, depending on site conditions.



## 5.5 Results of Cost Analysis

The results of the cost comparison for the four cranes is summarized in Table 5.2. The RO Stinger crane was not used in the analysis of Building No. 3 because small truck mounted cranes are not used as the primary crane on large projects and because the PRECISE Program does not provide accurate solutions for small cranes on large buildings. This is due to problems with the beam interference checking rules, when situations are encountered where no purlins be erected.

The results indicate that the Century 128 crane is the best crane for all three buildings. This crane costs more to transport to a project than the RO Stinger or P&H S20, but this is more than offset by greater productivity per setup and lower rental cost. For the Buildings No. 2 and 3, this crane can set twice as many pieces per setup as the S20, yet the crane radius is only 25% larger than the S-20. The largest crane, the Omega 50, has a crane radius 25% larger than the S-20, yet for Buildings 2 the Omega 50 set 50% more members per setup and for Building 3 only set 25% more members per setup than the Century 128. From Figure 5.1, it can be seen that simply increasing crane radius will not necessarily result in a proportionate decrease in the number of crane setups required for a building.

If the Century 128 is removed from consideration, for Building No. 1 the S-20 and RO Stinger have the least cost. This is because reduced transportation and daily rental costs offset the fact that less moves and consequently less total time are required of the Omega 50. For Building No. 2 the S-20 and the Omega 50 are almost equal in terms of cost. This is the

Table 5.2 Crane Cost Analysis

BLDG 1	RO STINGER	P&H S20	P&H CENT 128	P&H OMEGA 50
DAILY CRANE COST	\$250	\$275	\$210	\$395
TRANSPORTATION	\$200	\$200	\$700	\$1,000
LABOR COST/DAY	\$1,000	\$1,000	\$1,000	\$1,000
NO. OF PIECES	338	338	338	338
DAILY PRODUCTION	45	45	45	45
CRANE SETUPS	12	8	6	3
TIME/MOVE(HRS)	1	1	1	1
TOTAL TIME(DAYS)	8	8	8	8
TOTAL CRANE COST	\$2,265	\$2,403	\$2,356	\$4,041
TOTAL LABOR COST	\$8,261	\$8,011	\$7,886	\$7,699
TOTAL COST	\$10,526	\$10,414	\$10,242	\$11,740
BLDG 2	RO STINGER	P&H S20	P&H CENT 128	P&H OMEGA 50
DAILY CRANE COST	\$250	\$275	\$210	\$395
TRANSPORTATION	\$200	\$200	\$700	\$1,000
LABOR COST/DAY	\$1,000	\$1,000	\$1,000	\$1,000
NO. OF PIECES	560	560	560	560
DAILY PRODUCTION	45	45	45	45
CRANE SETUPS	55	41	21	14
TIME/MOVE(HRS)	1	1	1	1
TOTAL TIME(DAYS)	16	15	14	13
TOTAL CRANE COST	\$4,170	\$4,327	\$3,589	\$6,261
TOTAL LABOR COST	\$15,882	\$15,007	\$13,757	\$13,319
TOTAL COST	\$20,052	\$19,334	\$17,346	\$19,581
BLDG 3		P&H S20	P&H CENT 128	P&H OMEGA 50
DAILY CRANE COST		\$275	\$210	\$395
TRANSPORTATION		\$200	\$700	\$1,000
LABOR COST/DAY		\$1,000	\$1,000	\$1,000
NO. OF PIECES		847	847	847
DAILY PRODUCTION		45	45	45
CRANE SETUPS		104	53	42
TIME/MOVE(HRS)		1	1	1
TOTAL TIME(DAYS)		25	22	21
TOTAL CRANE COST		\$7,164	\$5,348	\$9,472
TOTAL LABOR COST		\$25,322	\$22,135	\$21,447
TOTAL COST		\$32,486	\$27,483	\$30,919

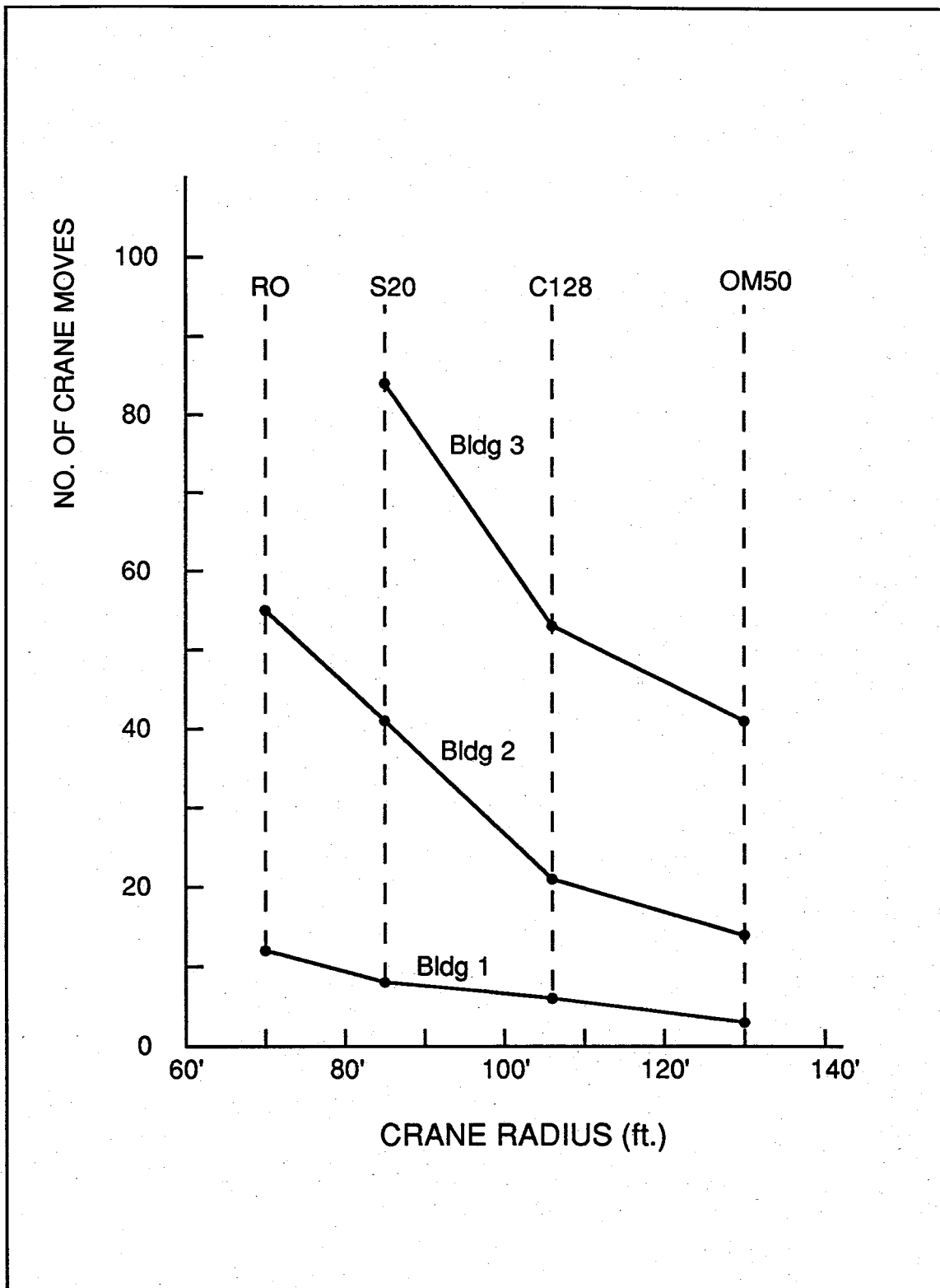

Figure 5.1 No. of Crane Moves as a Function of Crane Radius for 3 Buildings

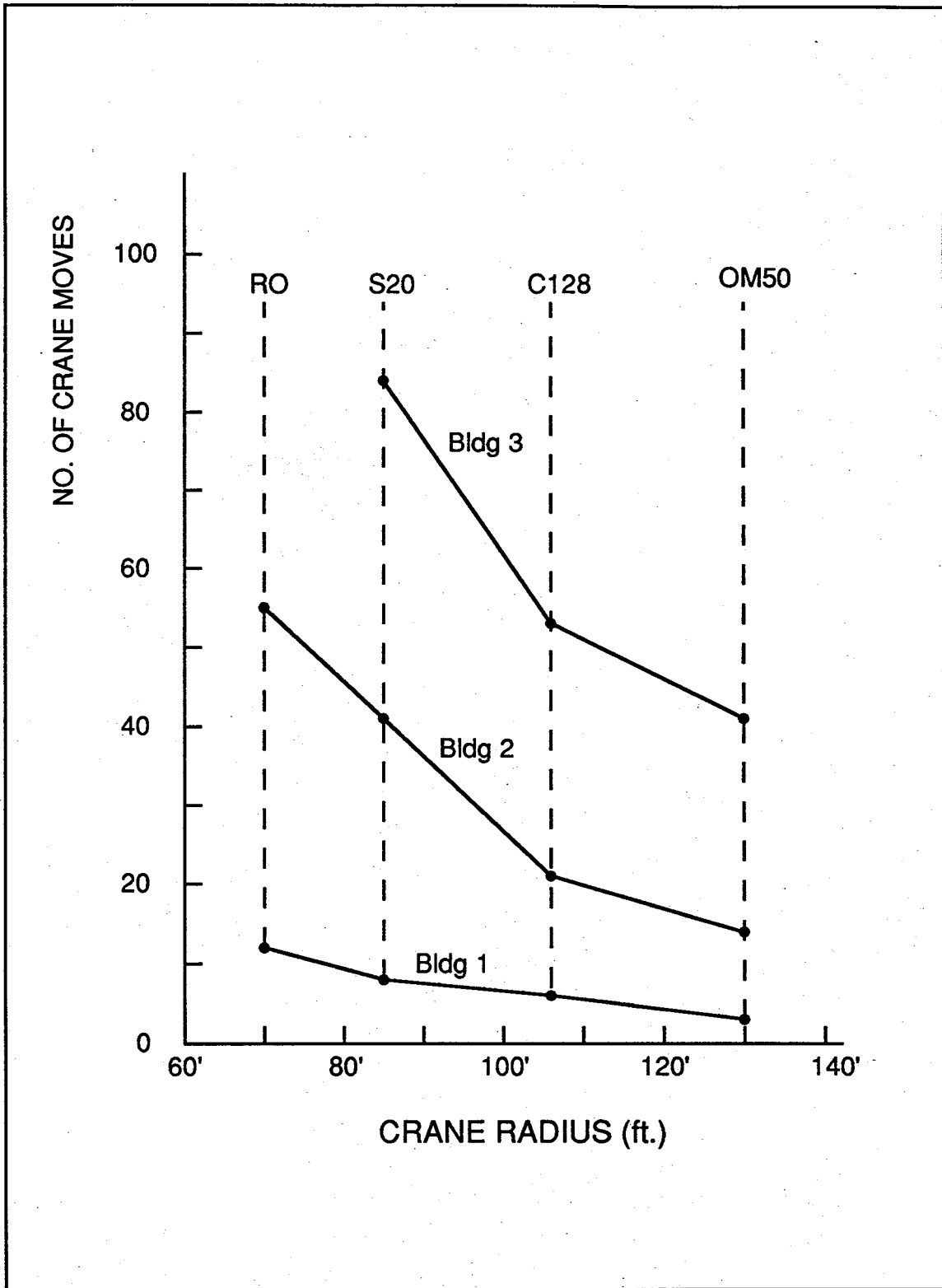

Figure 5.1 No. of Crane Moves as a Function of Crane Radius for 3 Buildings

breakeven point, because the Omega 50 is the least costly choice for Building No. 3.

The two smaller companies interviewed expressed a strong preference for mobile truck mounted cranes and all terrain cranes because of the flexibility in moving cranes from site to site. The Century 128 does not have this flexibility, especially if cranes have to be moved from site to site every day or two. However, it can be seen from the Building No. 1 analysis, that the Century 128 can be the most economical crane on projects with durations as short as seven days.

## **5.6 Summary**

This chapter has illustrated a method for estimating steel erection costs based on crane costs, labor costs, productivity and the number of crane moves for three different buildings using four different cranes. A total cost was calculated for each of the buildings.

The assumptions used may vary from contractor to contractor, especially regarding productivity and crane costs which are subject to great variability. For the buildings selected, the number of crane moves can not simply be predicted based on crane size or radius. However, the PRECISE program can provide useful information regarding the number of crane setups and serve to reduce some of the guesswork involved in analyzing erection costs.

## **CHAPTER 6**

### **CONCLUSIONS**

This chapter reviews the research goal and methods of accomplishment. The research contributions are presented. Examples of the benefits of the program to a steel erector are provided. Problem areas in program development and areas for further program development are discussed. The program concludes with suggestions for other applications of the program.

#### **6.1 Contributions**

The goal of this research was to find a method for optimizing steel erection with mobile cranes by finding the minimum number of crane setups. This was accomplished by interviewing steel erectors understand the process and information requirements for erecting structural steel. A generic building was developed consisting of basic structural elements. The steel erection procedures were converted into rules. A control strategy was developed to find the combination of crane positions that results in the minimum number of crane setups. The generic building, rules and control strategy were incorporated into a Prolog computer program to find the optimum crane positions and the structural members erected from each crane position. The program was tested on three different buildings using four different cranes to demonstrate how the results of the PRECISE program could be used to compare costs for different cranes and buildings.

One of the significant contributions of this research is that this program finds the crane positions required, where other research has required the user to select the crane position. The second contribution of this research is that it demonstrates a method of developing a logical representation for a construction process, in this case making structural steel connections, and combines it with geometric considerations of the building and crane to find an erection sequence for the building. The solution is not simply a computational approach to finding crane positions and erection sequences, but one which relies on logical rules, such as "beams must be erected prior to purlins."

## **6.2 Benefits of Using PRECISE**

The PRECISE program can be used to help a contractor to plan his work more efficiently, by finding the least number of crane setups required for a building. Erection planners usually choose the first acceptable plan for erecting steel, not bothering to evaluate all of the possible alternates, or they leave it up to the superintendent to determine in the field. Several examples are described which have been tested.

Planners generally divide the building into equal or nearly equal crane passes. Using the example discussed in Section 3.5.1 of a building 10 bays wide requiring a minimum of 4 crane passes, there are two possible pass combinations; the unequal combination of [1,3,3,3] bays and the nearly equal pass combination of [2,2,3,3] bays. Intuitively, the [2,2,3,3] bay may seem to be the best.

Using PRECISE, a crane similar to an RO Stinger was tested on a 105,600 sq. ft. building with these bay configurations. An option was added to the PRECISE program, that allowed the user to change the pass combination from the best combination selected by the program of [1,3,3,3] bays to a user selected alternate of [2,2,3,3] bays. The program was then able to proceed through the "crane\_sweeps" module and find all of the crane positions for the alternate pass combination. The combination of [1,3,3,3] bays selected by the PRECISE program required 20 crane setups, while the alternate selection of nearly equal crane passes of [2,2,3,3] bays required 22 crane setups. The end result is that 2 crane setups will be saved by using the PRECISE program solution.

Planners may not also consider dividing the building into multiple crane passes, if the crane can reach both corners of the building. Using a 39,000 sq. ft. building 4 bays wide, a crane similar to a P&H S-20 was tested for a single crane pass and two crane passes. The single pass required 13 crane setups, while dividing the building into two passes required only 8 setups, resulting in a saving of 5 crane setups.

The PRECISE program can be used as a reference or benchmark for comparing crane costs. A contractor may have two similar sized - but different - buildings which he is planning to erect with two different cranes. Each crane will not have the same efficiency for each building. By using PRECISE and an analysis similar to that used in Chapter 5, the contractor can determine if it is more cost effective to erect Building 1 with Crane A and Building 2 with Crane B, or Building 1 with Crane B and Building 2 with Crane A.



By finding the crane locations and the members which can be erected from each position, the PRECISE program can be used to plan unloading and delivery of materials. By adding component weights to each of the members, a cumulative total can be tracked, which can be used to schedule delivery of truckloads of materials.

The program can be used to help predict productivity. One of the problems in performing the cost analysis was obtaining accurate crane productivity data. A significant factor affecting crane productivity is the operating radius of the crane. If the operating radius exceeds 75% of the maximum radius, or "comfort zone," the operator will be more tentative in placing the load, causing productivity to decrease. A counter can be added to the PRECISE program which determines the percentage of members the crane will be required to set that exceed the "comfort zone."

### **6.3 Problem Areas**

One of the major problems in developing the PRECISE program was in debugging the program. The programmer must know when a rule will fail and provide an alternate rule which will succeed. When a rule fails, backtracking is initiated as was described in Section 4.6. If backtracking occurs because a rule fails unexpectedly, it is very difficult to trace. During the course of program development, there were at least four instances which took between eight and twelve hours to trace minor errors. Most of these problems occurred in the interference checking routines.

#### **6.4 Areas for Further Program Development**

There are three areas of development which are needed in order to make the PRECISE program a robust tool which can be used by steel erectors in a more meaningful way. These are: (1) the program should be able to consider unequal bay spacings; (2) the program should account for structural members with variable weights; and (3) the program should regard obstruction avoidance.

The first area for future program enhancement is to consider unequal bay spacings. Many buildings do not have consistent bay spacing throughout the structure. The program presently uses the equal bay spacing to simplify some of the calculations and bookkeeping tasks. Unequal bay spacing can be implemented, but all of the permutations for crane pass combinations will have to be determined. At present only the combinations are found.

The second area for further program development is the incorporation of weight considerations into the program. The weights of structural members can vary and this will affect the crane radius for each of the different loads. One approach may be to use a crane radius that satisfies the majority of the members and use a "normal" envelope as was done in the PRECISE program. The remaining overweight members would be divided into weight classes, each with a corresponding crane radius and special load circle around the center of the member. As the crane erects the steel, if the heavy load is within the "normal" crane envelope, the crane must be located within the load circle around the heavy load. This would result in a hybrid of the relational and analytic approach discussed in Section 3.4.

The third area of potential program development is obstruction avoidance, and how to locate the crane if an obstruction is encountered. This is very important to field personnel, who must develop alternate schemes in response to changing conditions at the site. Consideration must be given to the size of the obstruction and its impact on the overall erection plan. It must be determined whether it will affect one crane position, or several crane positions. If an obstruction such as a trench affects the most efficient route for the crane, it may be necessary to work on each side of the trench which will increase the number of setup points. If this increases the number of setup points above that of the second best route, it may be better to backtrack and attempt to avoid the obstruction by using the alternate route.

### **6.5 Other Applications**

The PRECISE program was developed in modular form. This makes it adaptable to determining the erection sequencing for multistory buildings. The rules for multistory erection sequencing will change slightly, since all tiers are set from a single location before moving the crane. Additionally the crane is usually located outside the building structure. As each tier is erected, it must be verified that the crane boom will clear the edge of the building when erecting the members in the back of the building for the next tier. If there is an interference, the members which cause the interference will have to be left out, and the building will be erected in a stairstep fashion. The modules, "find\_last\_row" and "check\_boom\_interference" can be readily adapted to a program for multistory erection.

Another application would be to customize the program for pre-fabricated metal building erection. Frequently in these buildings, beams span across more than two columns. The program can be modified for this type of erection by modifying the rules to require that all columns to which the beam connects be erected before the beam is erected. The program would also have to be modified to determine pass widths based on beam lengths, instead of the present bay spacings.

The program can also be adapted for evaluation of tower cranes to determine that the equipment selected is capable of erecting all the loads required. Similarly, the programs of this type can also be developed for other construction activities involving cranes. For example, pouring concrete requires that construction proceed in an ordered sequence. Rules can be developed that formwork must precede placing rebar which must precede placing concrete. Using this information, a program can determine the crane positions and activities to be performed in each position.

PRECISE could be useful for designers and constructors performing constructability reviews. By converting a CAD file of the building structure into a database format which can be read by the PRECISE program, such an application can be developed. The information developed by the PRECISE program on crane locations and crane envelopes could be written into a CAD file for the building structure, and provide a visual picture of the required erection sequence.

## 6.6 Summary

This research project was a successful project in terms of meeting the objectives set forth in Chapter 1. The results of the research, the PRECISE program, can be applied to improving construction productivity by finding the optimum the number of crane setups required to erect a building. The program can be used as an aid to select the appropriate crane for a project, to plan material flows, and to help predict crane productivity. The program is a starting point for developing a more robust planning program capable of considering varying bay spacing, varying member weights, and obstructions. Additionally, there are specific applications for the program in multistory and prefabricated building erection. Finally, the program can be integrated with other tools such as CAD and robotics.

X

**ANNOTATED BIBLIOGRAPHY**

Albert, E. A. "Introduction to Artificial Intelligence." Mining Engineering 597A, Pennsylvania State University, University Park, PA. May 1989.

Lecture presented at Pennsylvania State University.

American Institute of Steel Construction, Structural Steel Detailing, New York, 1983, Chapter 4.

Describes the preparation of structural steel fabrication and erection drawings.

American Society of Civil Engineers, Quality of the Constructed Project, New York, 1988, pp.37-39,99-113,135-139.

Provides guidelines outlining responsibilities of owner, design professional and constructor in providing quality in constructed projects.

Cleveland, A.B. "CAD, 3-D Modeling and Construction Management", The Construction Specifier, Vol. , No. , Apr. 1987, pp. 78-89.

Discusses advantages of Bechtel 3D Computer modeling system.

Clocksins, W.F. and Mellish, C. S. Programming in Prolog, 3rd edition, Springer-Verlag, 1987, pp.10-30.

The "bible" for programming in Prolog, this is an excellent reference text.

Cooper, C.N. "Cranes - A Rule-based Assistant with Graphics for Construction Planning Engineers," The Application of Artificial Intelligence Techniques to Civil and Structural Engineering, Civil Comp Press, Edinburgh, 1987, pp. 47-54.

Describes an expert system for selecting a tower crane based on the crane being capable of overswinging all off-loading areas and the cranes being capable of lifting materials at the same rate as the construction process. Divides site into load zoned polygons.

Construction Safety Association of Ontario, Mobile Crane Manual, Toronto, Ontario, 1982, pp. 215-273.

Complete descriptions of mobile cranes, operating procedures, and many load charts for different cranes.

Gray, C and Little, J., "A Systematic Approach to the Selection of an Appropriate Crane for a Construction Site", *Construction Management and Economics*, 3, pp. 121-144, 1985.

Describes an expert system and provides flow charts of the decision process for determining the most suitable crane for a given project.

Halpin, D.W., "International Competition and Construction Research," Symposium Proceedings of the Center for Integrated Facility Engineering, Stanford University, March, 1989.

Discusses high technology application to construction and areas where research initiatives are required.

Hanna, A.S. "An Interactive Formwork Selection System for Building," Ph.D. thesis, Pennsylvania State University, University Park, PA., 1989 .

Provides background and glossary on artificial intelligence in civil engineering application.

Heilich, C., L.C. Anderson General Contractor, Huntingdon, PA, Personal Interview, November, 1989.

Ibbs, C.W. "Future Directions for Computerized Construction Research," Journal of Construction Engineering, Vol 112, No. 3, Sept.1986, pp. 326-345.

Strategic plan for research in the following areas (1) project wide data bases, (2) knowledge systems, (3) simulations, and (4) robotics.

Jackson, P. *Introduction to Expert Systems*, 1st. ed., Addison Wesley, Reading, MA., 1986, pp. 10-11.

Background on artificial intelligence and definitions of knowledge.

Kangeri, R. and Halpin, D.W., "Potential Robotic Utilization in Construction, *Journal of Construction Engineering and Management*, Vol. 115, No. 1, Mar. 1989, pp.126-143.

Rates potential applications for robotics according to need based feasibility, technological feasibility, and economic feasibility. (Cranes were rated 31/33 NBF, 16/33 TF, 27/33 EF, Structural Steel was rated 24/33 NBF, 25/32 TF, 2/33 EF)

Kumara, S., Kashyap, R.L., Soyster, A.L., "Artificial Intelligence and Expert Systems - A General Introduction," Artificial Intelligence Manufacturing Theory and Practice, Institute of Industrial Engineers, pp. 1-31, 1989.

Introduction to artificial intelligence problem solving techniques and knowledge representations.

Laird, P., "Introduction to Tower Cranes and their use in Commercial Construction", Civil Engineering Report(unpublished), Purdue University, 1983.

General description of tower cranes, including mobile tower cranes.

Lundy, R.S., Lundy Construction Company, Williamsport, PA, Personal Interview, November 1989.

Marker, R.A., R.A. Marker & Son Steel Erections, Lewiston, PA, Personal Interview, August, 1989.

Nunnally, S.W., Construction Methods and Management, 1st ed., Prentice-Hall, Inc., Englewood Cliffs, N.J., pp 46-48, 296-312, 1980.

Background on cranes and steel erection. Discusses divisioning of steel and planning as related to fabrication and erection. Provides some information on crane parameters - boom length, boom angle and boom position.

Oppenheimer, S.P. Erecting Structural Steel, McGraw-Hill Book Company, New York, 1960, pp. 157-181.

Although dated, the planning and erection procedures described still apply for mobile cranes.

Peurifoy, R.L. and Oberlender, G.D., Estimating Construction Costs, 4th ed., McGraw-Hill, pp 369-381, 1989.

Describes methods for estimating costs for erection of steel structures; provides cost information for labor on hourly basis and rates of erecting structural steel for various types of equipment.

Ralston, D.W. Artificial Intelligence and Expert Systems Development, McGraw-Hill, New York, 1988, pp.1-87, 229-241.

Provides background theory on artificial intelligence knowledge representation and problem solving techniques.



Rapp, W.G., Construction of Structural Steel Building Frames, John Wiley & Sons, Inc., New York, pp.110-159, 1980.

Describes erection scheme for steel erection, various crane alternatives, methods of shipping in installments, tiers, preparation of erection diagrams, methods of erecting different types of buildings, erection scheme diagrams.

Ricker, D.T. "Value Engineering and Steel Economy," 1988 Proceedings of the National Steel Conference, American Institute of Steel Construction, pp.39.1-39.25.

Discusses erectability requirements and possible cost savings through improved design for steel structures.

Rowe, N.C., Artificial Intelligence Through Prolog, Prentice-Hall, Englewood Cliffs, NJ, 1988, pp. 1-97.

Very practical guide to Prolog programming with good examples.

Sanvido, V.E., An Integrated Process Model, Technical Report No. 1, CIC Research Program, Department of Architectural Engineering, The Pennsylvania State University, 1990.

Describes basic processes required to provide a facility which can be broken down into subprocesses.

Shapiro, H. I., Cranes and Derricks, 1st ed., McGraw-Hill, Inc., New York, pp. 181-247, 1980.

Describes different types of cranes, explains methods for calculating swing clearances and support requirements for cranes. Discusses positioning and selecting mobile cranes.

Simon, J.L. and Burstein, P. Basic Research Methods in Social Science, Random House, New York, 1985, pp.37-38, 165-183.

Provides information on case study approach to data gathering and proper survey and interview techniques.

Thomas, H.R., Sanvido, V.E., and Sanders, S.R. "Impact of Material Management on Productivity -- a Case Study," Journal of Construction Engineering, Vol 115, No. 3, Sept.1989, pp. .

Compares the material unloading and storage procedures for two projects, showing benefits of proper organization and planning. Apply rules of credit to determine daily production.

Wijesundera, D.W. and Harris, C.F., "The Integration of an Expert System into the Construction Planning Process," The Application of Artificial Intelligence Techniques to Civil and Structural Engineering, Civil Comp Press, Edinburgh, 1985, pp. 31-37.

Describes development of an expert system to aid in selection of equipment for a construction site. Explains problems with dealing with uncertainty.

## APPENDIX A

### DERRICKS AND CRANES USED IN STEEL ERECTION

#### A.1 Introduction

The purpose of this appendix is to orient the reader to the types of lifting equipment used in steel erection. The basic types of lifting equipment are derricks, tower cranes and mobile cranes. Variations of each are also described.

#### A.2 Derricks

Derricks are devices for raising, lowering, and/or moving loads laterally through the use of a hoisting mechanism which is not an integral part of the machine. It consists of a mast or equivalent member held at the head by guys or braces. It may or may not have a boom.

##### A.2.1 Guy Derrick

The guy derrick (Figure A.1) is the most common derrick used in high rise steel construction. It sits on the top tier of steel and is jumped up as each tier of steel is erected. It consists of a mast and boom which are guyed with wire ropes to the building structure. The boom is shorter than the mast and is able to swing clear of the guy lines when raised to a nearly vertical angle, permitting 360° operation. This is ideal for the narrow beams and

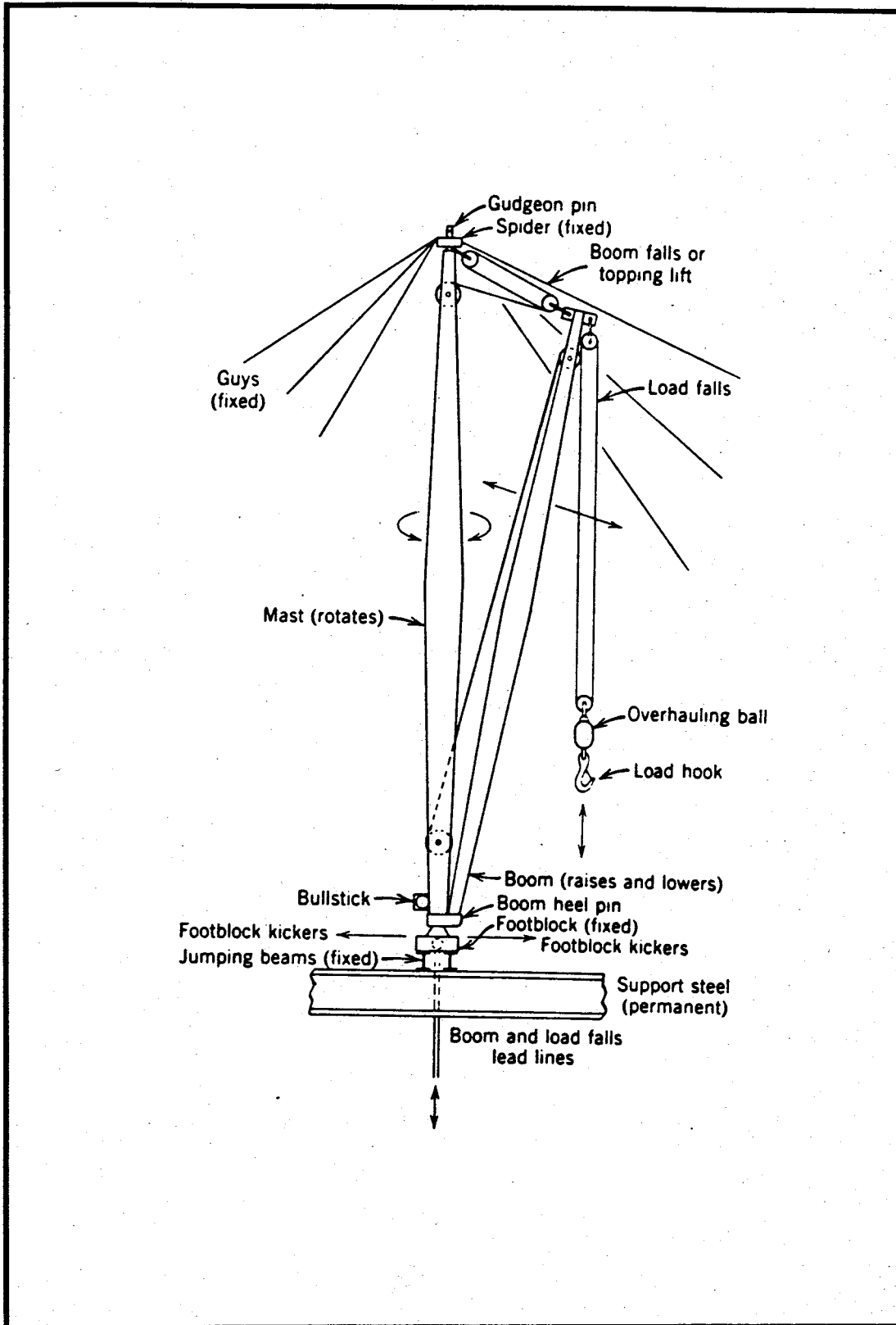

Figure A.1 Guy Derrick (Shapiro, 1980)

columns which are encountered in structural steel erection. The mast and boom pivot together around a fitting at the head called a gudgeon pin. The bottom is fitted with a ball and socket fitting. The load is lifted by a hoisting mechanism and the radius of operation is changed by raising the boom with the topping lift. Both lift mechanisms are external to the derrick. A winch operated bull wheel or extension lever (bullstick) is attached to the mast above the ball and socket joint and is used to swing the load. As each tier of steel is erected and the new decking is placed, the derrick is jumped to the next tier. This is accomplished by disassembling the boom, using it to raise the mast and then using the mast to raise the boom. Typical derrick sizes are 125 ft. masts with 100 ft. booms. Capacities can range up to 200 tons.

Since most steel connections will have only two erection bolts in them when the derrick is set in position, an analysis must be made of the derrick loads and the guy point loads to determine if the connections are adequate.

**Advantages:** 360° operation; low capital cost; requires no ground space.

**Disadvantages:** Requires crane for initial setup; jumping operation requires considerable effort; additional temporary supports may be required for derrick and guy points.

### **A.2.2 Chicago Boom**

The Chicago boom is a variation of the guy derrick. It does not have a mast but uses the structure for attaching the topping blocks. This requires that the base be set at least one floor below the top floor if horizontal beams

are used, or mounting the boom on a column which results in a very complicated lead line arrangement to permit 270° operation.

### **A.2.3 Stiffleg Derrick**

Another variation of the guy derrick is the stiffleg derrick (Figure A.2) which is used in situations where the boom may interfere with the support guys. The guys are replaced with two structural members which support the mast and are approximately 90° apart.

## **A.3 Tower Cranes**

This section discusses various types of tower cranes.

### **A.3.1 Fixed Tower Cranes**

Tower cranes (Figure A.3) have come into increased usage in high rise construction during the last ten years, largely supplanting the derrick. Tower cranes utilize horizontal booms, commonly called jibs, mounted at the top of a tower. The jib is able to swing or slew a complete 360° circle horizontally about the vertical axis of the tower. The load block is attached to a trolley which runs along the jib to control the operating radius of the crane. The base is attached to a concrete support foundation by anchor bolts, or by setting the fixed base section in the concrete when the foundation is poured (Laird, 1983). Tower cranes are capable of lifting loads very quickly and can operate in winds to 50 mph. Generally the towers are erected by mobile

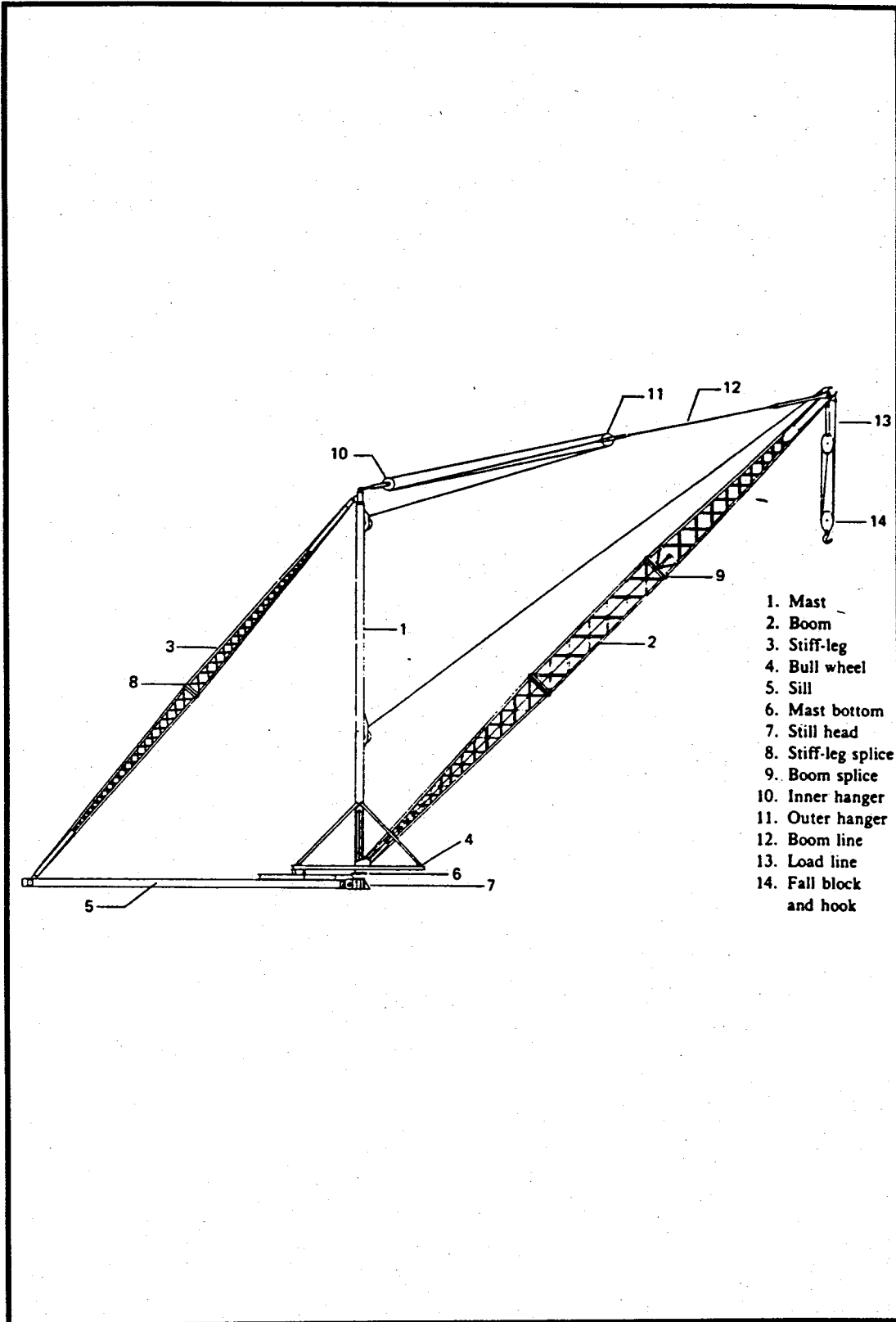

Figure A.2 Stiffleg Derrick (Smith, 1986)

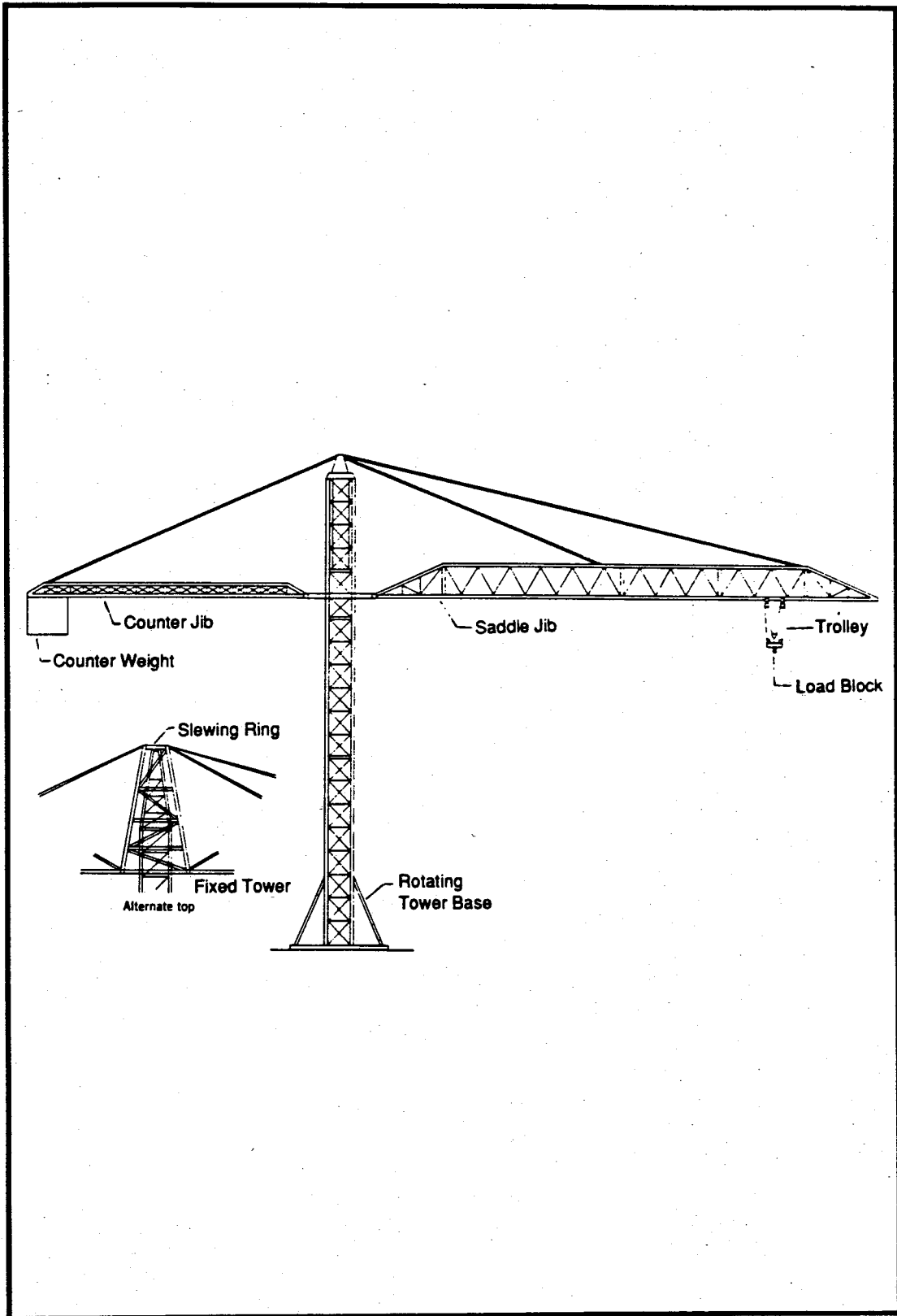

Figure A.3 Tower Crane (Rapp, 1980)



cranes but in some cases they may be self-erecting. Self-erecting cranes have no limit on their height. Up to a certain height, load and boom radius govern the design of the crane. Above that point, wind and storm loads govern (Shapiro, 1980)

The horizontal boom may be either fixed in the horizontal plane or may articulate in the vertical plane. Fixed jibs are called hammerheads or saddle jibs. The jib opposite the saddle jib is the counter jib and houses the counterweights and hoist. The other jib type, called the luffing jib or articulating jib, raises and lowers to vary the swing radius. Luffing jibs are commonly used where there may be obstructions such as other buildings within the swing circle of a fixed jib.

Crane towers may be of two basic types. The first is the fixed tower in which there is a slewing ring at the top of the tower, permitting only the jib to turn. As the jib turns, the tower legs are alternately in compression and tension. The other type is the slewing tower which rotates the tower and jib simultaneously eliminating the cyclic stresses in the tower legs. Tower cranes may be capable of lifting up to 55 tons with a 250 ft. jib.

**Advantages:** Wide operating radius, nearly unlimited height, speed, ability to work in adverse conditions.

**Disadvantages:** Set up time, foundation preparation, and dismantling costs require that crane be set up for long periods to be cost effective.

### **A.3.2 Climbing Tower Cranes**

Climbing tower cranes(Figure A.4) use the interior of the building structure such as an elevator shaft to support the crane and are supported

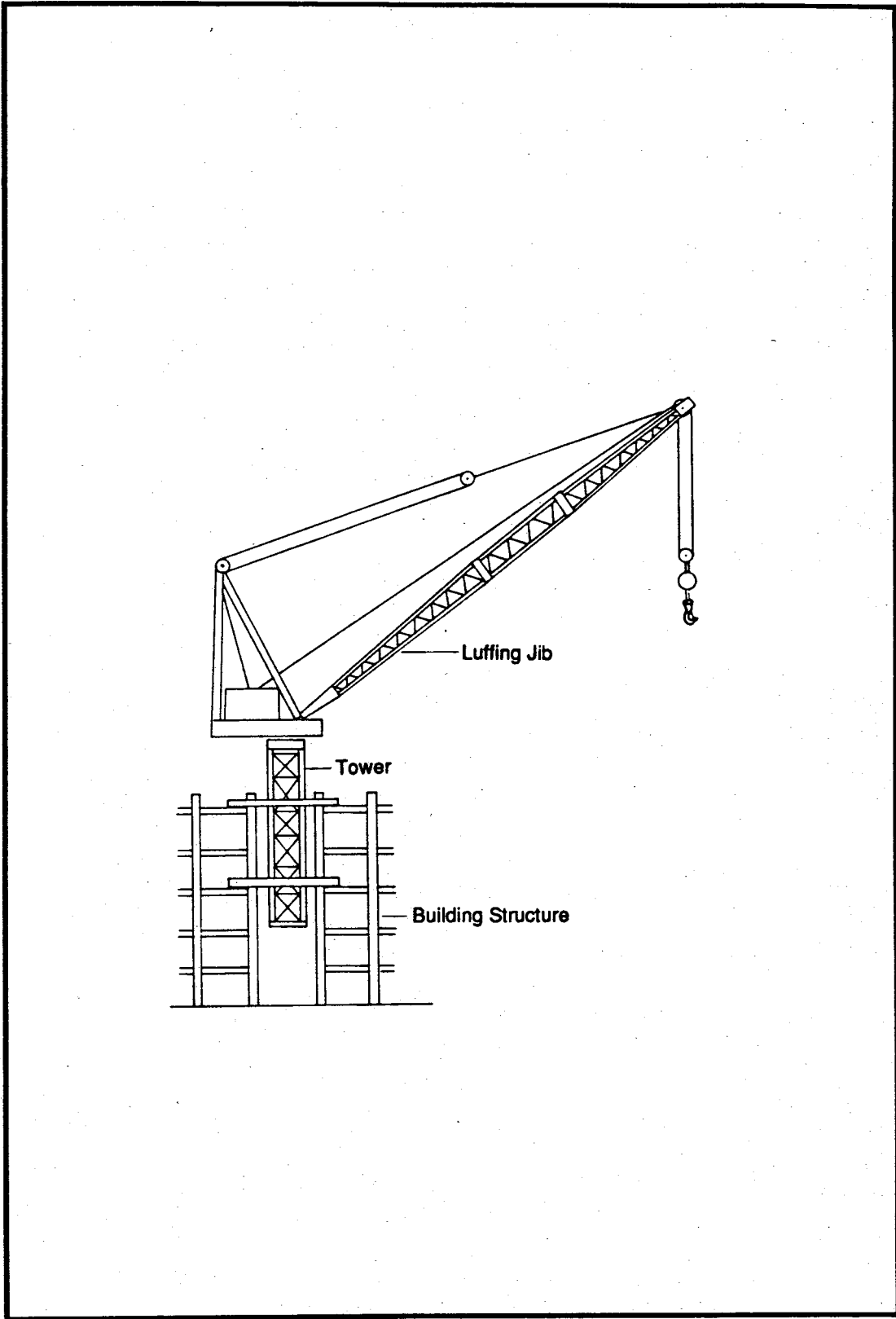

Figure A.4 Climbing Tower Crane (Rapp, 1980)

by the building floor on which they rest. Climbing is accomplished by hydraulic rams. After climbing, the tower is wedged to the building structure at two levels to resist any overturning moment.

### **A.3.3 Traveling Tower Cranes**

Traveling tower cranes are tower cranes which attempt to combine the advantages of a tower crane with the mobility of a mobile crane. These cranes are free standing cranes which operate on a track. They are capable of traveling with a load. Special provisions are provided for parking the tower under storm conditions. Specialized cases of traveling cranes are truck and crawler based cranes which can be adapted to tower cranes.

## **A.4 Mobile Cranes**

A mobile crane is defined as a crane which can move freely about the jobsite under its own power without being restricted to a predetermined path (Shapiro, 1980). Mobile cranes are used in less restricted areas where there is access around the site or where the site covers a large area such as an industrial facility or a warehouse. They can be used on multistory buildings up to 7 stories.

### **A.4.1 Undercarriages**

The basic undercarriages for mobile cranes are crawler bases, truck carriers or rough terrain carriers.

Crawler bases utilize large tracks as the means of traction. The large track area in contact with the ground distributes the load over a greater area, enabling them to travel on soft ground and grades up to 30%. They are cheaper than truck cranes, but because of their width and inability to travel over the road, they must be assembled at the jobsite.

Truck-type crane carriers (Figure A.5) are designed to be self-transporting on the highway as well as the jobsite. Since most American highway limits are 80,000 lbs., the design of these cranes attempts to minimize weight as much as possible. These cranes are equipped with hydraulic outriggers which support the crane when lifting loads and provide for additional stability.

Rough terrain carriers have two axles with large tires which are capable of operating under adverse site conditions, such as mud and deeply rutted roads. Both axles articulate, making these machines very maneuverable. Rough terrain carriers are commonly called cherry pickers and can achieve speeds of 30 mph.

Crawler bases are used on the highest capacity cranes, followed by truck carriers on intermediate capacity cranes, and rough terrain carriers on light capacity cranes. Load ratings are given for over the front of the crane and over the side of the crane. Figure A.6 shows the areas of operation for different mobile crane bases.

#### **A.4.2 Booms**

There are two kinds of booms in common use on cranes. The first is called a lattice boom which is a fixed length boom utilizing a truss design.

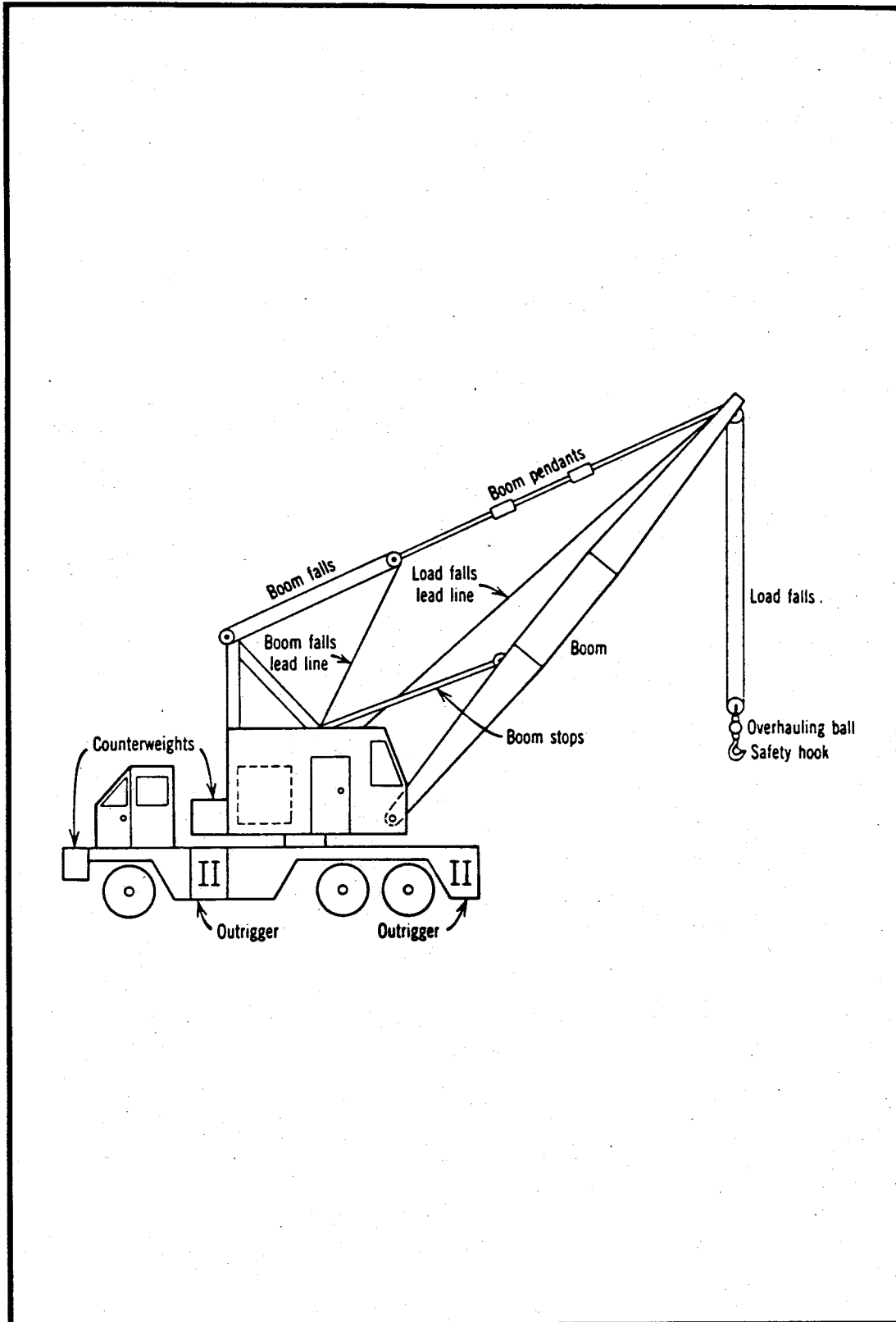

Figure A.5 Truck Crane (Shapiro, 1980)

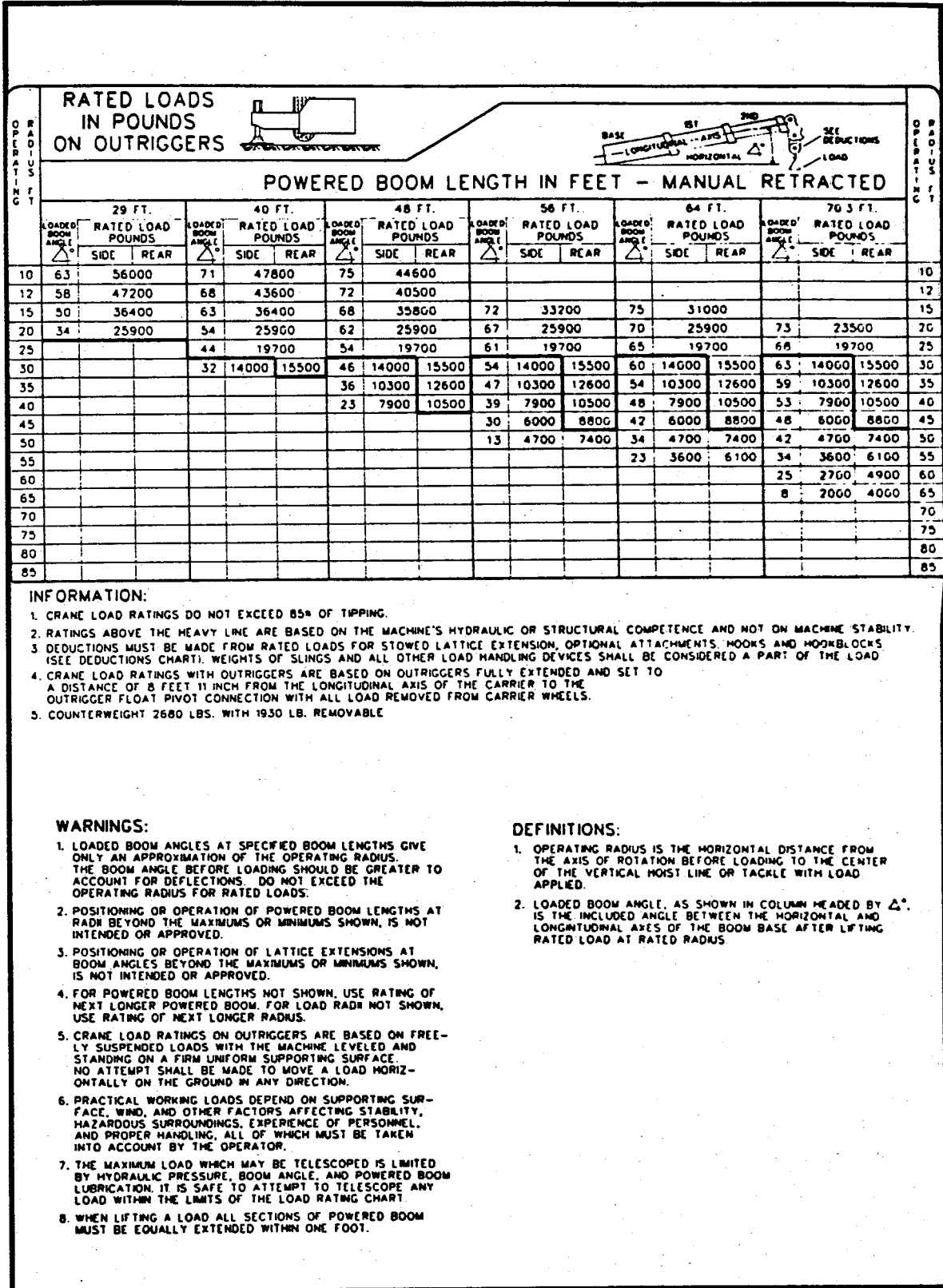

Figure A.6 Load Rating Table for P&H 28 Ton Hydraulic Crane

The boom consists of a butt section which is attached to the the crane upper structure, standard inserts for varying the boom length, and a boom tip to which the load blocks are attached. Except for extremely long booms, most cranes are capable of self-lifting the boom. Short lattice booms are capable of hoisting 500 ton loads and boom lengths may be up to 350 ft. long (Shapiro, 1980). Lattice booms are used on crawler bases and truck carriers.

Telescopic booms require no special set-up or assembly. The booms are made of symmetric sections which fit within each other. The largest base section is fixed to the crane body. With in the base section are the intermediate sections and an end section (or fly section) with the load and lead blocks . The intermediate and fly boom sections are extended and retracted on rollers or sliding pads by hydraulic extension cylinders. The booms resist load by cantilever bending action.

If the slide pads or rollers develop wear and are not properly maintained, the actual operating radius of the crane will be greater than shown on the boom angle indicator in the cab, increasing the tipping moment and creating a potentially unsafe condition.

Telescoping booms may be as long as 175 feet and are capable of lifting loads of 300 tons at short boom radii. They are usually used on truck mounted cranes or rough terrain carriers.

Jib booms can be added to lattice booms or telescoping booms to reach greater heights or extend the reach of a crane. The angle of the jib is fixed relative to the boom, with a maximum of 45 degrees. The jib is for light loads only and has only one line through the load block with a light hook on the end.

Advantages: Mobility; ease of set up; good for short term projects.

Disadvantages: Maneuvering room is required which may not be available on all sites; practical height limit is seven stories at which time tower crane or derrick becomes more economical (Marker, 1989).

## A.5 Crane Load Ratings

Cranes and derricks are rated for a given load and boom angle at a specific radius. Tables are provided by the manufacturer, rating crane loads for recommended boom lengths at recommended radii. Figure A.6 shows a typical load diagram. Load capacity may be limited by the structural strength of the components such as hydraulic rope strength, winch capacity or boom strength. All load capacities include the weight of the rigging and load blocks, which must be subtracted from the rated load capacity, to obtain the weight of the load that can be lifted. Rated load capacities for mobile cranes are based on the crane operating on a firm, level and uniform operating surface with outriggers being fully extended (PCSA, 1986).

For mobile cranes, as the operating radius increases, stability becomes the governing factor. This is especially important in steel erection, where the loads are relatively light and it is desirable to maximize reach from each crane position. The tipping load is determined by equating the machine moment to the boom moment and the load moment as given in the equation and as shown in Figure A.7:

$$W_m d_m = W_b d_b + W_l d_l$$

The tipping line or fulcrum is the line of the outriggers for truck cranes and rough terrain cranes or the centerline of the treads for crawler bases.



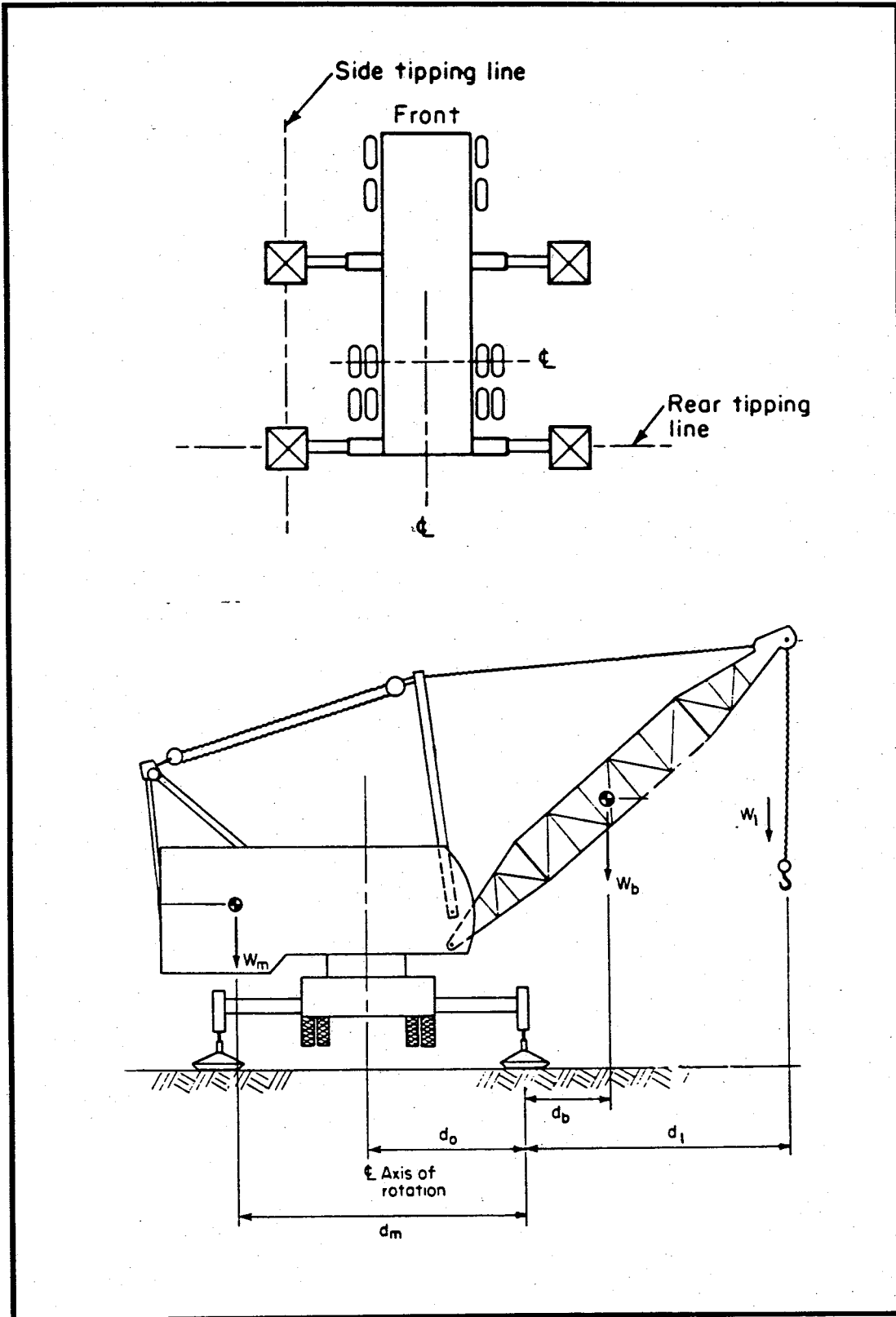

Figure A.7 Tipping Moment for Mobile Cranes (Shapiro, 1980)

This formula applies when the boom is perpendicular to the tipping line. As the crane rotates in the horizontal plane the center of gravity of the upper carriage, boom and load approach the centerline, while the lower carriage moment remains constant. The result is a lower tipping moment and increased crane stability. To simplify the problem crane manufacturers rate cranes for  $\Theta = 0^\circ$  (over the rear) and for  $\Theta = 90^\circ$  (over the side). The load ratings assigned by the crane manufacturers are 85% of the the tipping load for cranes on outriggers, as determined by tests in accordance with SAEJ-765 under very controlled conditions. For crawler and wheeled machines, the ratings are based on 75% of the tipping load. Figure A.8 shows the areas of operation for various crane configurations.

Other factors may affect the operation of cranes. Wind loads may act on the boom and increase the tipping moment. Dynamic loads may increase the operating radius when lifting or swinging the load. Out of level operation may also increase the operating radius. Adequate supports are required to assure that the crane is operated from a level position (Shapiro, 1980).

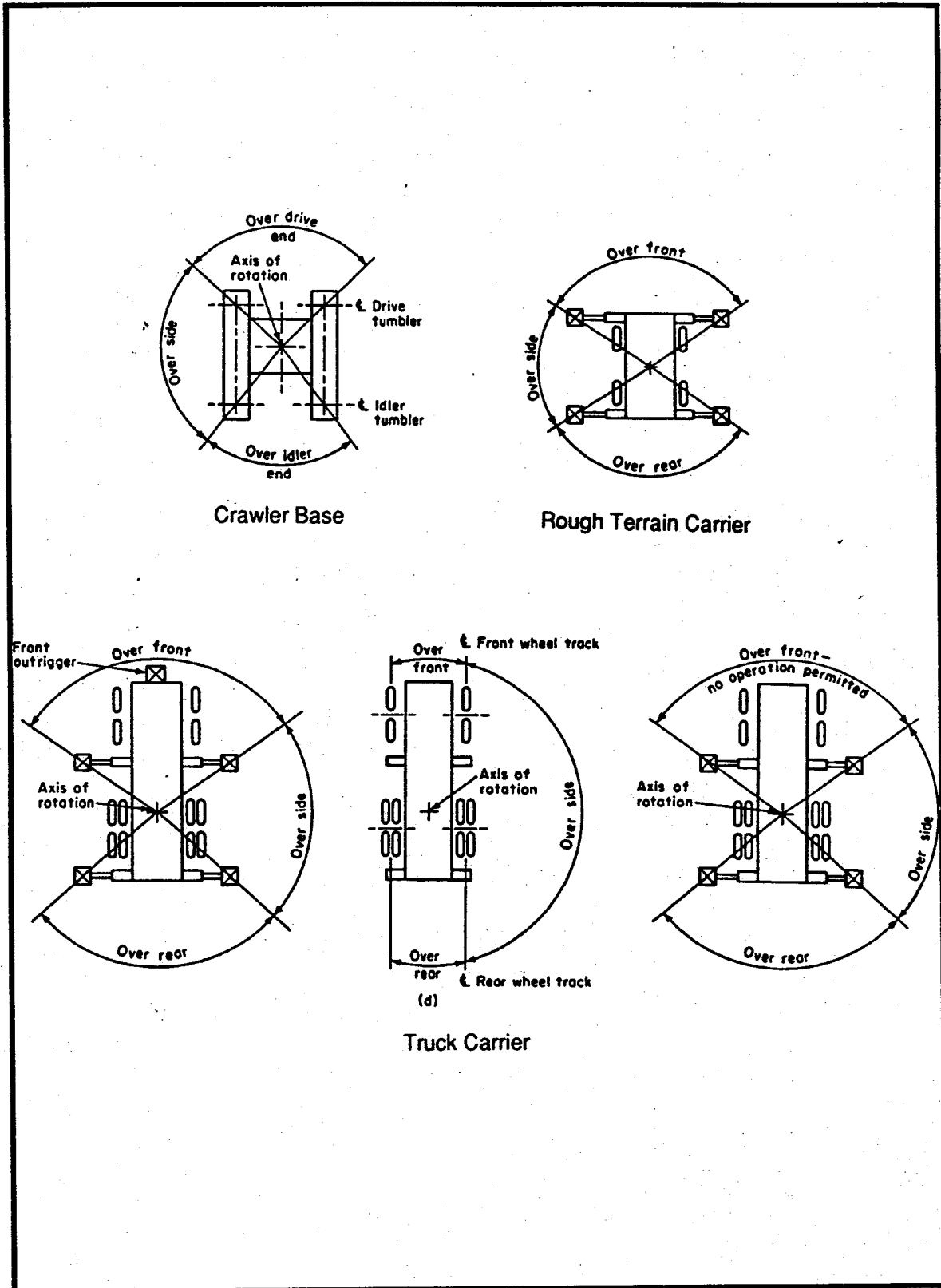

Figure A.8 Mobile Crane Areas of Operation (Shapiro, 1980)

## **APPENDIX B**

### **INTERVIEW PACKAGE**

This Appendix contains the interview package which was used to interview steel erectors to determine planning methods for using mobile cranes to erect structural steel. It consists of four parts: (1) Section B.1, Outline of the Interview Procedure, (2) Figure B.1, Planning Diagram for Develop the Erection Plan, which supports the questionnaire, (3) Section B.2, Questionnaire for Planning Steel Erection, and (4) Section B.3, Information Checklist.

#### **B.1 Outline of Interview Procedure**

The purpose of establishing an interview procedure is to establish a consistent method for obtaining and evaluating data collected from steel erectors. The outline is listed below:

- I. Introduction
  - A. Explain research is on planning to make cranes more productive in erecting steel
  - B. Focus on single story steel structures
  - C. Emphasize planning in terms of crane selection and crane positioning
- II. Describe Planning Diagram (Figure B.1) & Questionnaire
  - A. Explain boxes on diagram represent functions in planning process

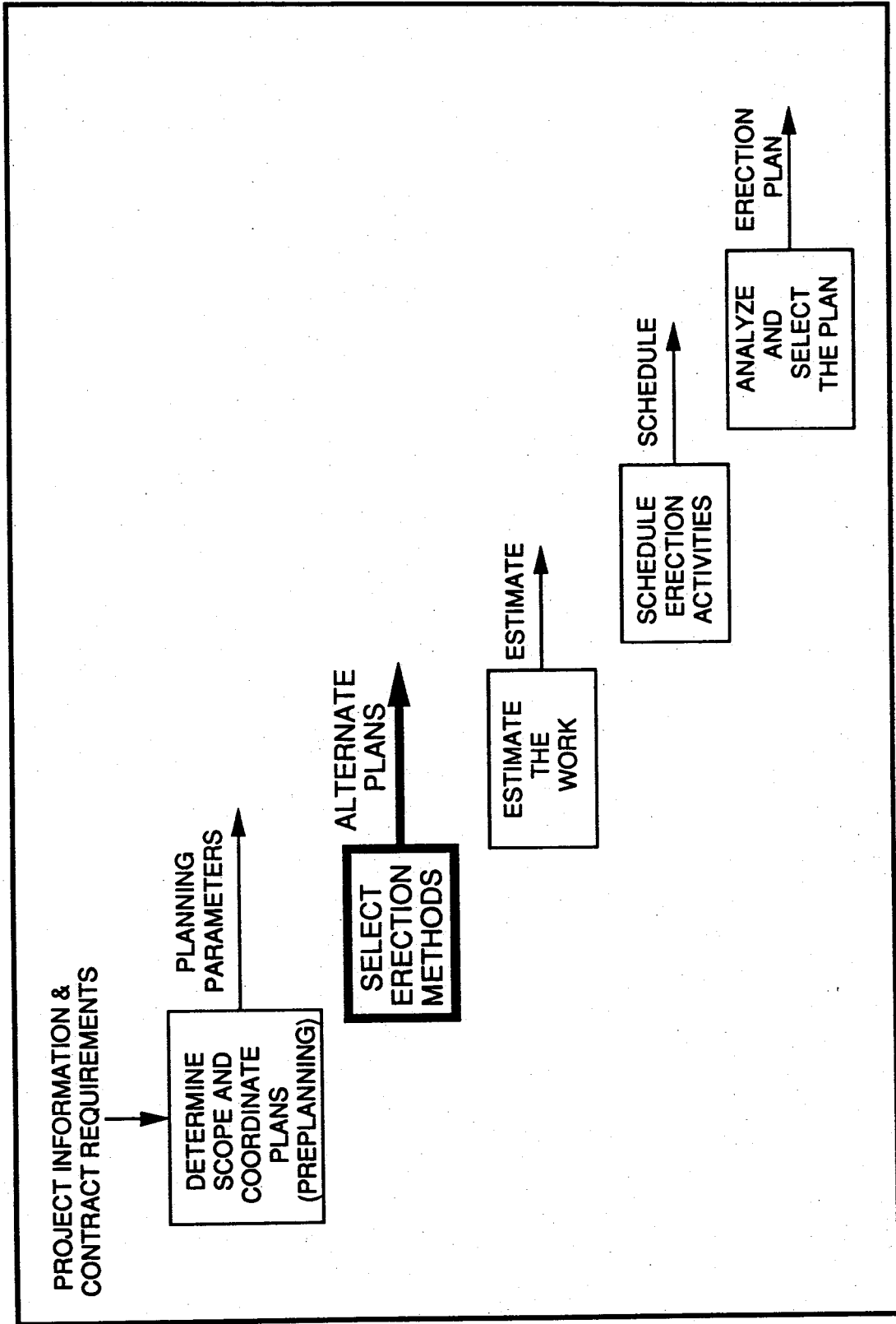

Figure B.1 Diagram for Develop the Erection Plan

- B. Explain that arrows represent information
- C. Relate how questionnaire parallels diagram
- D. Focus on "Select Erection Methods"
- E. Review Questionnaire
- F. Tape record
- G. Obtain descriptions of each of the processes using diagram and questionnaire as a guide:
  - 1. Information required
  - 2. Description of function
  - 3. Responsibility for function
  - 4. Information generated

### III. Information Checklist

- A. Review
- B. Add items which may have been left out

## B.2 Questionnaire for Planning Steel Erection

The purpose of the questionnaire is to obtain specific procedures for planning steel erection using mobile cranes and determine how this information relates to other planning functions. The questionnaire which is based on the Integrated Building Process Model for Developing the Construction Plan is listed below:

**B.2.1 General**

- 1) What size buildings does your company erect?
- 2) What sizes and types of cranes are used to erect these buildings?
- 3) Is crane useage shared with other contractors or trades during steel erection? Will it remain on site?
- 4) What is your experience in steel erection?(Number of buildings and size categories)

**B.2.2 Determine Scope and Coordinate Plans**

- 5) Describe in general terms the preplanning process for erecting structural steel in terms of divisioning of the steel, fabrication/ erection decisions,and co-ordination with other contractors?
- 6) What information from the Owner and Designer is required for preplanning?

**B.2.3 Select Erection Methods**

- 7) How do you evaluate/determine the equipment you will use for a project?
- 8) Describe how you determine the erection sequence for a building.

- 9) How do you determine the positions for setting the crane?
- 10) How do unloading and delivery requirements affect the possible erection schemes (e.g. shakeout)?
- 11) How do you determine the crew sizes for erecting a building?
- 12) Site parameters may be determined from the site plan and site visit. What specific factors do you look for that would constrain you in determining work methods?
- 13) What information from the working drawings issued by the structural engineer is utilized in determining work methods.
- 14) What information in the specifications may affect the erection methods (e.g. inspections)?
- 15) What other information may affect the erection scheme?
- 16) What past construction experience or rules of thumb do you apply in selecting erection methods?
- 17) What labor and equipment alternatives may affect the erection method selection?
- 18) What codes and regulations may affect the selection of erection methods and sequence?
- 19) How is the result of the decisions on erection methods communicated and who uses this information.



**B.2.4 Estimate the Work**

- 20) What historical cost data is used to develop the estimate?
- 21) How does the estimate affect the development of the erection scheme?

**B.2.5 Schedule the Work**

- 22) What historical productivity and crew size data is used to develop the schedule?
- 23) How does the schedule affect the development of the erection scheme?

**B.2.6 Analyze and Select the Plan**

- 24) Describe how alternative erection schemes are evaluated when allocating equipment and labor.
- 25) What processes or information requirements have I left out in planning the erection scheme.

### **B.3 Information Checklist**

The purpose of the information checklist is to identify all the information needed by the contractor for the planning the erection of structural steel. The information checklist, which is based on a literature search is listed below:

#### **I. CONTRACT DOCUMENTS**

##### **A. DRAWINGS**

1. Building Layout (Footprint)
2. Member shapes
3. Member wt/ft
4. Member locations
5. Member orientation
6. Other

##### **B. SPECIFICATIONS**

1. Material Requirements
2. Quality/Inspection Requirements
3. Erection Tolerances
4. Other

##### **C. MISC**

1. Penalty Clauses
2. Warranty Requirements
3. Payment Schedule
4. Milestone Dates
5. Other

**II. PROJECT INFORMATION****A. MEETINGS**

1. Minutes
2. Changes

**B. SITE INFORMATION**

1. Site Layout
2. Temporary Facilities Location
3. Access Paths to Building/Traffic Patterns
4. Obstructions
5. Other

**C. SITE CONDITIONS**

1. Soil Conditions
2. Anticipated Weather Conditions
3. Other

**D. SUBMITTAL FEEDBACK**

1. Approved Erection Drawings
2. Piecemark Numbers
3. Piecemark Locations
- 4/ Approved Fabrication Detail Drawings
5. Bolt Placement Lists
6. Other

**E. RESOURCE AVAILABILITY**

1. Crane/Equipment Information
2. Load Charts
3. Other
4. Labor Availability

5. Other

**F. SAFETY STANDARDS**

1. Regulations affecting Labor
2. Regulations affecting Equipment
3. Other

**G. PAST CONSTRUCTION KNOWLEDGE**

1. Methods Experience
2. Cost Records
3. Past Schedule Performance
4. Productivity Data
5. Equipment Costs
6. Other

**APPENDIX C****COMPANY A****PLANNING STEEL ERECTION USING A MOBILE CRANE****C.1 General**

The following case study is based on an interview with the owner and project manager of Company A on August 18, 1989. Company A is a steel erector located in central Pennsylvania.

Company A erects single story steel structures up to 1,000,000 sq. ft. and multi-story structures up to 6 stories. They use mobile cranes in the 40 to 75 ton range. The cranes have both hydraulic, telescoping booms and lattice booms. All cranes are rubber tired. For single story construction, hydraulic cranes with a 120 ft. reach over the side are predominantly used. For multi-story construction, the lattice boom crane is utilized, with 170 ft. of boom and a 60 ft. jib. Tower cranes which are used for heavy lifts or high rise construction are not utilized because the market is limited to downtown construction in cities. All equipment is owned by the company and only projects which are within the company's equipment range are bid. Leasing has been found to make the bid non-competitive.

**C.2 Determine Scope and Coordinate Plans (Preplanning)**

Steel must be properly sequenced for delivery to match the erection plan. Generally steel is shipped in divisions of 60,000 sq. ft. Steel should be erected in a continuous flow, sequencing from one end of the building to

the other. It is desirable to plan to set steel in one area, and as each area is completed to unload steel for the next area. It is important to have the steel shipped in small enough sequences, so that steel for opposite ends of a large building are not mixed. The optimum situation is to schedule in large enough sequences, that scheduling does not become a management problem, but in sufficiently small areas that repositioning the crane for "shake out" is minimized.

### **C.3 Select Erection Methods**

In planning the erection of single story building, project size determines the size of the crane. Warehouse projects can be up to 500 ft. wide. It is desirable to erect as much steel as possible from a single position. Hydraulic cranes are ideal because of the simple set-up required and their ability to handle the relatively light loads of the structural members normally encountered in single story buildings at long radii.

It is necessary to determine the crane capacity and weight of pieces at the furthest radius of the crane. Using this information, the center points point of the swing circles can be determined based on the obtained from the load chart. Generally, the weights of structural members are consistent, but variability may be encountered. An example is when an interior column is left out and the girder may be twice the normal length. The weight may be three times that of single span girders. Generally girders are in the range of 1 to 1-1/2 tons. The heaviest loads are generally girders in joist girder designs and roof beams in cantilever beam design. When planning crane

lifts, it is a good idea to provide a safety factor and plan to work at 75% of crane capacity.

#### **C.4 Planning Information**

Planning information is provided in the form of steel erection drawings and specifications. The most important information is the footprint of the building and member sizes. Information on connection types is important when preparing the estimate, but is not a factor in placing the steel. Because a complete set of drawings, including site arrangement drawings is not furnished to the steel erector, a site visit is necessary to finalize the erection plan. Soil conditions, areas not backfilled, and laydown locations must be determined from the site visit. Specification information which may affect the erection plan is welder certification requirements, insurance requirements, and special requirements in the erection specification. These special requirements may be grouting, setting leveling plates, and touch up painting.

#### **C.5 Estimate**

The bid estimate is prepared based on the number of pieces of steel and erection productivity rate, which is generally between 50 and 65 pieces per day. This productivity rate is based on historical records for different types of structures, and is not based on a formal analysis of productivity for different cranes. Productivity will increase if there are repetitive members. Safety regulations will also affect the productivity rate. For example, in

Pennsylvania each member must be lifted individually, whereas in Maryland "fish lining" is permitted. When "fish lining," several members may be lifted in one operation, each member being tied to the member above by a wire rope. Estimates based on total tonnage of steel and building square footage may also be prepared, but these are used only for comparison with other projects and to check the bid estimate.

### **C.6 Schedule**

Schedules are based on starting and completion dates which are provided by the general contractor. Bar charts are used on larger projects, but formal schedules are not generally used. A schedule board is used to plan equipment and manpower allocations on a company wide basis.

### **C.7 Analyze and Select the Erection Plan**

The final erection plan is based on the availability of equipment. Frequently a project will be started with one crane and completed with another. The general rule of thumb is to use larger cranes on larger projects.



## **Erection Procedure**

The erection procedure for a single story metal building is outlined. The building described consists of rows of columns and girders which run across the width of the building. The column rows are connected by beams which run along the length of the building at the columns. Also running along the length of the building, are joists, which connect to the girders between the columns. The procedure is as follows:

- (1) Begin at one end of the building, working inside the footprint of the building.
- (2) Determine the first crane position by checking the loads of the corner columns and connecting girders.
- (3) Use this load information to determine the radius of the crane load circle.
- (4) The intersection of arcs whose radius is equal to the crane load circles, determines the initial setup location for the crane.
- (5) Erect a line of columns and girders across the building, beginning from one side and working to the other side in sequence. Do not erect from the sides and work toward the middle, as this may cause plumbing and alignment problems, when fitting the last girder in place.
- (6) Erect the second row of columns and girders, working back toward the crane.
- (7) Erect beams and joists which connect between first and second row of columns and girders

- (8) Continue this process of setting a row of columns and girders and interconnecting beams and joists, up to the crane.
- (9) Erect the end columns on the side of the crane and the beams which connect to the previously erected row of columns. These end columns will be the center of the load circles which determine the next crane location and will permit the crane to be set further back. Setting only one column on each side of the crane will not affect the plumbing and alignment of the steel, when the remaining columns and girders in this row are erected from the next crane position.

**APPENDIX D**  
**COMPANY B CASE STUDY**  
**PLANNING STEEL ERECTION USING A MOBILE CRANE**

**D.1 General**

The following case study is based on an interview with a project manager for Company B conducted on November 22, 1989. Company B is a general contractor located in central Pennsylvania.

Company B erects single story buildings of conventional frame design and pre-engineered metal buildings. Many of the metal buildings they erect are on a design-build basis, where they engage an engineer for the design work. The buildings they construct range in size from 500 sq. ft to 180,000 sq. ft. They are an Armco Metal Building Representative for the Huntingdon area.

They use a 20 ton P&H hydraulic all terrain crane and a 12 ton Stinger hydraulic crane mounted on the bed of an International triaxle truck. They also employ a Dynalift rough terrain forklift for unloading and moving materials on site.

**D.2 Determine Scope and Coordinate Plans (Preplanning)**

The preplanning for a pre-engineered metal building consists mainly of determining the sequencing of the steel shipments and co-ordinating this with the manufacturer. Sequencing may be dictated by owner occupancy requirements in cases where the owner may need to set up equipment prior

to the completion of the entire structure. The milestone dates and schedule are established in the construction contract with the owner. Weekly or biweekly job conferences are held with the owner to coordinate planning.

This sequencing will in turn affect other contractors who must complete their work to satisfy the owner's needs. As an example, the sequencing of shipping and erection of HVAC ductwork and sprinkler piping will have to follow the same sequence as the structural steel. Since Company B is a general contractor, they also attempt to do the concrete work, which gives them tighter control over the locations of column footings and anchor bolts. This also gives them control over construction methods. Column footings are poured to exact elevations and steel trowel finished, eliminating the need for shimming column baseplates.

Structural framing steel is normally shipped in truckload quantities of 30,000 lbs. and is separate from loads of roof and wall covering which are shipped in lighter loads because of their bulk. It is very important that roof covering be shipped with the structural steel so that it can be placed on the roof as the steel is erected. After the roof purlins are erected for one bay, the roof covering is laid on the purlins prior to the erection of the purlins in the next bay. The bundles of covering weigh about 500 lb. and are set with a crane which can use a spreader bar. The Dynalift forklift cannot be used for this because the forks are too close together and the sheets will bend.

### **D.3 Select Erection Methods**

The choice of the crane is based primarily on anticipated site conditions and mobility requirements since both cranes can handle the

majority of the buildings encountered in pre-engineered metal building erection. The P&H crane operates on hydraulic outriggers which may require using timber mats underneath if site conditions are muddy. If the subgrade and the stone base have been placed and compacted, the crane may be able to operate on the footprint of the outriggers. It has more mobility, since both axles articulate. The Stinger has less site mobility since it is mounted a truck body, but can be moved quickly from one project to another and can be used to haul other equipment and materials.

The determination of the positions for setting the crane are determined by the foreman in the field. One frame is set at a time. The foreman is given latitude in the exact erection sequence, and determines whether he will move the crane across a building to the ridge line or operate on the same travel path, backing the crane up as each portion of a frame is erected.

Competition and the use of computers among the manufacturers of pre-engineered metal buildings has resulted in good shipping sequences which match the erector's needs. Shipping lists are provided in advance of material delivery which permit the foreman on the job to preplan unloading of material. The Dynalift forklift has been very important in providing flexibility in unloading and moving materials. No longer must a crane be used to unload material when site conditions prevent spotting a truck in the erection area. The dynalift can unload a 30,000 lb. truckload of steel in 40 minutes and then be used to shake out the material. Rafters and columns are stacked, and separated by 2x4's permitting the forks of the Dynalift to unload them without using slings or chokers. Purlins and sheeting arrive in bundles which must be sorted into the sequence they will be erected. The

Dynalift is used to move the materials into the final lifting area where they can be picked by the crane.

The normal crew size for erecting a building is six men, including the supervisor for the structural steel skeleton. On larger jobs, 10 men will be used. The additional manpower can be used for ground assembly of parts. In planning the the crews for a building, it is very important to use skilled workers on the roof sheeting where special care must be taken in properly installing fasteners and properly using the required sealants. The Dynalift has permitted using more men on a project, since it can move materials which previously required the use of the crane.

#### **D.4 Planning Information**

Site conditions which most affect the construction plan is drainage and possible locations for the staging area. If the site area is limited, the staging area may be inside the building. It is desirable to spot siding outside the building, which requires an open area approximately 10 ft. wide. When Company B is a subcontractor, access requirements are included with the bid.

Information on the drawings which is required in planning erection are the building footprint and the profile of the building which show changes in roof heights and breaks in the lines of the building. Weights of members is not considered important, since loads are not considered a factor in developing the erection plan.

Safety codes which bear on the erection plan are OSHA requirements which govern safety for men working in the air, such as

requirements for ladders, scaffolding, and safety belts and crane safety requirements.

Decisions on erection methods are communicated between the job foreman and superintendent. A meeting will be held to advise of any special needs or requirements regarding the erection sequence. The foreman's input is very important at these planning meetings.

#### **D.5 Estimate**

Historical data used to develop the estimate for structural steel based on unit costs per pound of steel. For jobs with larger quantities of steel the unit price decreases. Estimates are based on the number of bays or frames, the weights of the steel and square feet of wall and roof covering required. All information received from the manufacturer regarding weights is lumped together and is not broken out but could be calculated from take-offs on the drawings and shipping lists.

#### **D.6 Schedule**

Historical productivity data is based on erecting two frames per day and adjusted based on the width of the building. Sheeting is based on placing 3000 to 5000 sq. ft./day of roofing. Schedules are developed from these productivity rates. The owner's schedule and milestone dates will determine the crew sizes and amount of equipment used on a project.

### **D.7 Analyze and Select the Plan**

Company B does not have any formal analysis system for selecting construction plans based on comparing estimates and schedules for alternate erection schemes. The decisions on erection sequences are left to the foreman in the field, as it is felt he is best able to make these decisions.

### **D.8 Erection Procedure**

The following rules describe the procedure for the erection of structural steel on a prefabricated metal building:

- 1) Beginning at an endwall, erect an outside column and adjacent interior columns required to support the largest rafter that can be handled by the crane.
- 2) Set several rows of columns which are within reach of the crane.
- 3) Bolt rafter sections together on the ground and set rafters on columns, moving the crane as required to set each of the columns
- 4) After first two rafters are set, tie frames together with eave girt and purlins. Set bundle of purlins on roof frame and spread out. Set roof bundles on purlins after purlins are spread out. As each additional rafter is set, set purlins and roof bundles.
- 5) After four frames have been set, move the crane back to the end wall and repeat the process of erection to the ridge line.



**APPENDIX E**  
**COMPANY C CASE STUDY**  
**PLANNING STEEL ERECTION USING A MOBILE CRANE**

**E.1 General**

The following is a case study based on an interview with the president of Company C conducted on November 27, 1989. Company C is a third generation family held general contractor with over 30 years experience in steel erection. Most buildings are pre-engineered metal buildings or conventionally framed buildings which are built within a 75 mile radius of the main office in central Pennsylvania. They are a local representative for a pre-engineered metal building manufacturer. Most of these buildings are built on a design-build basis, where f C prepares the drawings and acts as the general contractor.

Pre-engineered metal buildings range in size from 5,000 to 150,000 sq. ft. In the last two years, they have erected an increasing number of larger buildings in the range of 80,000 to 150,000 sq. ft. Company C's total volume has been about 500,000 sq. ft. annually for the past three years.

Company C uses a small 14 ton hydraulic crane or a 30 ton P&H hydraulic truck crane on smaller buildings under 30,000 sq. ft. On larger buildings they use a 30 ton Lorraine truck crane with a 80 ft. of lattice boom and a 30 ft. jib or a 35 ton Linkbelt hydraulic truck crane. On larger projects, a Lull forklift is used to feed material to the cranes. A trend in recent years has been toward taller buildings in warehouses, where 32 ft. eave heights

are not uncommon. This has necessitated using cranes with offset jibs to be able to reach over roof rafters to set roofing and purlins in back bays.

All cranes are owned by Company C and may be leased out to other contractors, but are used by Company C exclusively during the erection of steel on a project.

## **E.2 Determine Scope and Coordinate Plans**

Determining the scope of the project requires that the owner's needs be determined. This is usually accomplished with the design-build contract agreement. Most of the projects are fast track projects, with steel erection beginning in as little as 6 weeks after the completion of design and placement of the order with the manufacturer. Certain detailed information is required from the owner regarding office layouts and mechanical equipment. This is usually the most complicated part of the building. Proper planning requires that simpler parts of the building begin first, while details are worked out in these areas.

Coordinating plans in the preplanning phase requires that a starting point be determined for steel erection. This requires that the steel be divisioned or phased on projects larger than 50,000 sq. ft. The shipping of components from the building manufacturer must be sequenced to follow the erection flow. Preplanning also requires that the foundation work be coordinated with the steel erection. Since most of the buildings are erected with Company C acting as general contractor, by doing their own foundation work, they are able to control quality and schedule and perform coordination internally. As general contractor, they also have control over site conditions

enabling them to establish access roads and laydown areas to suit their needs.

Coordination with other contractors involves determining what foundations, trenches, and piping may be in the way of steel erection and developing solutions to these problems. Additionally, it is desirable to have a compacted subgrade for the floor slab in prior to steel erection, on which the crane can operate. If possible, plans are made to pour portions of the floor slab along the outside walls, allowing these areas to be used for material storage and ground assembly of rafters.

### **E.3 Select Erection Methods**

The equipment selected for a project is sized to match the project. The objective is to achieve the greatest efficiency by making the least number of crane moves. All cranes operate on hydraulic outriggers which must be set on timber mats each time the crane moves. It takes 15 to 20 minutes to move the crane. In the winter, when sites are muddy, this time increases.

The positions for setting the crane are left to the foreman in the field. Decisions are based on experience. Seldom in metal building erection is the crane near the load limit in erecting pieces, but if there is a question the foreman will provide the operator information on the load. The operator will determine if a load can be lifted for the planned crane radius by checking the load charts.

The crane should be centrally located place relative to the pieces being erected, and operating with a 50 to 75 ft radius. The ideal crane

position utilizes swing and cable instead of booming up and down or moving crane.

Unloading and delivery requirements do not generally affect the erection plan relative to erection sequencing or crane positioning since an attempt is made to have the subgrade prepared for the entire building and unload and shake-out steel on one area of the subgrade. The material is then fed to the crane using a forklift.

Crew sizes for pre-engineered metal building erection generally consist of a foreman and four men, and an operator. During unloading there are two men on the ground and two men on the truck. During erection there are two men on the ground hooking on steel and ground assembling rafters and two men in the air making rafter connections, spreading and bolting purlins. On larger jobs, two additional men are used to work ahead of the erection crew finding bolts and sorting parts or behind the erection crew or working the forklift feeding materials and spreading and bolting purlins.

#### **E.4 Planning Information**

Site parameters which operate as constraints to the erection process are open trenches, overhead wires and incomplete foundations. The most important information from the working drawings is the height of the building, the bay spacing, and the weights of members which are over 60 ft. Weights of members is determined from shipping lists.

Specification information is generally developed internally since most projects are design-build. The most important information is the manufacturer's standards for construction, AISC erection tolerances and the

BOCA code. A publication which describes the process and methods for erecting metal buildings, called Wheels of Learning, published by the Association of Building Contractors is used as a training guide for improving productivity and quality.

Schedule information may also affect the erection scheme. For example, it is very important that foundation work precede steel erection.

Rules of thumb which have been generated from past construction experience are: (1) to use larger cranes and feed material to the crane using a forklift on larger projects, (2) to build from within the building (delaying pouring floor slabs in areas required for crane travel, and (3) to locate the crane in as central location as possible holding the swing angles to 90 degrees.

Resource availability which may affect the erection of the steel are the availability of larger cranes if the job is a big one, requiring the use of a smaller crane than is desirable and the availability of good supervision (foremen). These require that the overall company schedule balance the schedule of the individual projects. This is accomplished by developing composite barcharts for all projects and individual barcharts for each project.

Safety standards which affect erection methods are OSHA standards. Presently the biggest problem is developing a practical method for the use of safety nets on tall pre-engineered metal buildings.

The selection of erection methods are determined and communicated to the foreman in a prejob planning meeting. The foreman is provided a packet of erection drawings which he reviews and scheduling details are worked out. He will make decisions on crane locations in the field. If there

are special considerations such as safety netting, a draftsman may draw up the layout of the netting for use by field forces. If there are special erection problems, a model may be prepared of the building. After a project begins, biweekly or weekly progress meetings are held to update schedules and review progress.

### **E.5 Estimate**

The initial bid estimate for a design-build pre-engineered building is prepared prior to design work and is not influenced by the selection of erection methods, except for site parameters which may be considered. Historical records are used in preparing the estimate, and are adjusted to suit the needs of each project. Factors affecting the estimate have been the increasing productivity of labor as a result of open shop contracting and more efficient equipment such as hydraulic cranes, all terrain forklifts, and mobile scissor scaffolds. Erection costs are now represent only 35% of a building's structural cost.

### **E.6 Schedule**

The most critical aspect of resource utilization within the Company C organization is finding the right foreman for a project. This requires that the the overall company schedule of foremen assignments be balanced with individual project schedules. CPMs are developed for larger projects when required and bar charts are developed for smaller projects. On projects where CPMs are used, they are boiled down to bar charts for use by the

foremen in the field. The effect of erection methods on the schedule is not formally analyzed, but there is an informal analysis which develops during the pre-job planning meeting.

### **E.7 Analyze and Select the Plan**

There is no formal analysis of alternative erection plans and their effects on the schedule and cost estimate. However, drawings are reviewed with field personnel, decisions are made on equipment which will be utilized, how the steel will be sequenced, and formal schedules are developed. Some of this may begin on what is called "back of the envelope planning", but Company C is satisfied that this provides the flexibility needed in their market niche.

### **E.8 Erection Procedure**

The erection sequence for a pre-engineered metal building is as follows:

- (1) Unload and shake-out the steel. Shake-out is the process of laying out the pieces where the identifying numbers can be read and placing the pieces in an order consistent with the planned sequence of erection. This process usually takes a day. An attempt is made to delay side walls and roofing, such that it lags behind erection of the structure and does not get in the way until the frames, purlins and girts to which it fastens have been erected.

- (2) With the crane inside the building lines and beginning in the braced bay which is generally the second frame, erect the corner columns if the crane can reach across the width of the structure . Plumb the frame.
- (3) If there are intermediate columns, erect them at this time. If the crane cannot span across the structure, erect the intermediate columns from one side to the ridge line or centerline of the structure.
- (4) If there are intermediate columns, and the crane cannot reach the corner and the center, divide the building an integer value of paths which are approximately equal and which are within the reach of the crane selected.
- (5) Leave the endwall framing out, unless it cannot be erected later from outside the structure.
- (6) Rafters should be ground assembled and set in the largest single piece which the crane will handle, minimizing the number of connections which will be made in the air.
- (7) Rafters must span the columns which have been erected. If the rafter length is over 60 ft., verify that it is within the load range of the crane.
- (8) Crane swing from the pick point to the erection point should be limited to 90 degrees.
- (9) As each frame (rafter and column assembly) is set it should be connected to a previously erected frame by purlins.
- (10) Set purlins on the rafters in bundles
- (11) Spread the purlins and bolt to rafters
- (12) Set roof bundles on purlins.
- (13) Erect columns and rafters, moving back toward the crane, and moving the crane as necessary.



(14) Move back 80 to 100 ft. and then come across and start along the next travel path.

**APPENDIX F**

This appendix contains the computer output which was used in the crane cost comparisons referenced in Chapter 5. It also contains the output for the examples cited in Chapter 6.

## Run No. 1

## Building Data:

Building Area = 39600 sq.ft.  
10 X-dir cols @ 20 ft; 12 Y-dir cols @ 20 ft; Beam Elev = 20 ft.

## Crane Data:

Model RO Stinger  
Crane radius = 70 : Boom Length = 87  
Boom Pivot Height = 10.5 : Setback = 10

The Crane will require 12 setups to erect 338 members  
An average of 28.17 members can be erected from each setup point

## Run No. 2

## Building Data:

Building Area = 39600 sq.ft.  
10 X-dir cols @ 20 ft; 12 Y-dir cols @ 20 ft; Beam Elev = 20 ft.

## Crane Data:

Model P&H S20  
Crane radius = 85 : Boom Length = 103.4  
Boom Pivot Height = 9 : Setback = 12.5

The Crane will require 8 setups to erect 338 members  
An average of 42.25 members can be erected from each setup point

## Run No. 3

## Building Data:

Building Area = 39600 sq.ft.  
10 X-dir cols @ 20 ft; 12 Y-dir cols @ 20 ft; Beam Elev = 20 ft.

## Crane Data:

Model P&H Century 128  
Crane radius = 105 : Boom Length = 114.5  
Boom Pivot Height = 9.75 : Setback = 12

The Crane will require 6 setups to erect 338 members  
An average of 56.33 members can be erected from each setup point

Run No. 4

Building Data:

Building Area = 202800 sq.ft.  
14 X-dir cols @ 30 ft; 14 Y-dir cols @ 40 ft; Beam Elev = 30 ft.

Crane Data:

Model RO Stinger  
Crane radius = 70 : Boom Length = 87  
Boom Pivot Height = 10.5 : Setback = 10

The Crane will require 55 setups to erect 560 members  
An average of 10.18 members can be erected from each setup point

Run No. 5

Building Data:

Building Area = 202800 sq.ft.  
14 X-dir cols @ 30 ft; 14 Y-dir cols @ 40 ft; Beam Elev = 30 ft.

Crane Data:

Model P&H S20  
Crane radius = 85 : Boom Length = 103.4  
Boom Pivot Height = 9 : Setback = 12.5

The Crane will require 41 setups to erect 560 members  
An average of 13.66 members can be erected from each setup point

Run No. 6

Building Data:

Building Area = 202800 sq.ft.  
14 X-dir cols @ 30 ft; 14 Y-dir cols @ 40 ft; Beam Elev = 30 ft.

Crane Data:

Model Century 128  
Crane radius = 105 : Boom Length = 114.5  
Boom Pivot Height = 9.75 : Setback = 12

The Crane will require 21 setups to erect 560 members  
An average of 26.67 members can be erected from each setup point

## Run No. 7

## Building Data:

Building Area = 202800 sq.ft.

14 X-dir cols @ 30 ft; 14 Y-dir cols @ 40 ft; Beam Elev = 20 ft.

## Crane Data:

Model P&H Omega 50

Crane radius = 130 : Boom Length = 140

Boom Pivot Height = 9.9 : Setback = 12.5

The Crane will require 14 setups to erect 560 members

An average of 40 members can be erected from each setup point

## Run No. 8

## Building Data:

Building Area = 520000 sq.ft.

14 X-dir cols @ 40 ft; 21 Y-dir cols @ 50 ft; Beam Elev = 30 ft.

## Crane Data:

Model P&H S20

Crane radius = 85 : Boom Length = 103.4

Boom Pivot Height = 9 : Setback = 12.5

The Crane will require 104 setups to erect 847 members

An average of 8.14 members can be erected from each setup point

## Run No. 9

## Building Data:

Building Area = 520000 sq.ft.

14 X-dir cols @ 40 ft; 21 Y-dir cols @ 50 ft; Beam Elev = 30 ft.

## Crane Data:

Model P&H Century 128

Crane radius = 105 : Boom Length = 114.5

Boom Pivot Height = 9.75 : Setback = 10.5

The Crane will require 53 setups to erect 847 members

An average of 15.98 members can be erected from each setup point

## Run No. 11

TEST: Pass Combination = [1,3,3,3] bays

## Building Data:

Building Area = 105600 sq.ft.

11 X-dir cols @ 40 ft; 12 Y-dir cols @ 24 ft; Beam Elev = 20 ft.

## Crane Data:

Model RO Stinger

Crane radius = 75 : Boom Length = 85

Boom Pivot Height = 9.75 : Setback = 7

The Crane will require 22 setups to erect 373 members

An average of 16.95 members can be erected from each setup point

## Run No. 12

TEST: Pass Combination = [2,2,3,3] bays

## Building Data:

Building Area = 105600 sq.ft.

11 X-dir cols @ 40 ft; 12 Y-dir cols @ 24 ft; Beam Elev = 20 ft.

## Crane Data:

Model RO Stinger

Crane radius = 75 : Boom Length = 85

Boom Pivot Height = 9.75 : Setback = 7

The Crane will require 24 setups to erect 373 members

An average of 15.54 members can be erected from each setup point

Run No. 13

TEST: Pass Combination = [4] bays

Building Data:

Building Area = 38400 sq.ft.  
5 X-dir cols @ 40 ft; 13 Y-dir cols @ 20 ft; Beam Elev = 18 ft.

Crane Data:

Model P&H S20  
Crane radius = 85 : Boom Length = 105  
Boom Pivot Height = 9.75 : Setback = 12

The Crane will require 13 setups to erect 177 members  
An average of 13.62 members can be erected from each setup point

Run No. 14

TEST: Pass Combination = [2,2] bays

Building Data:

Building Area = 38400 sq.ft.  
5 X-dir cols @ 40 ft; 13 Y-dir cols @ 20 ft; Beam Elev = 18 ft.

Crane Data:

Model P&H S20  
Crane radius = 85 : Boom Length = 105  
Boom Pivot Height = 9.75 : Setback = 12

The Crane will require 8 setups to erect 177 members  
An average of 22.13 members can be erected from each setup point