



# Revised Thesis Proposal

**Bryan Darrin – Structural Option**

Thesis Advisor – Dr. Linda Hanagan

Date of Submission – January 14<sup>th</sup>, 2011

## Table of Contents

Table of Contents.....	2
Executive Summary.....	3
Introduction.....	4
Structural System.....	6
Problem Statement.....	11
Proposed Solution.....	12
Solution Method .....	14
Breadth Studies.....	15
Breadth Study I - Architectural.....	15
Breadth Study II – Construction Management.....	15
Task and Tools.....	16

## EXECUTIVE SUMMARY

Millennium Hall is the newest residence hall on the Drexel University Campus located in Philadelphia, Pennsylvania. The 17 story building stands out from its surroundings with its unique shape, a slender tower appearing to spiral upwards. The majority of the building is clad with a combination of glass and aluminum. The tower is comprised of a cast in place concrete flat plate system.

With the absence of any sub grade levels, the Millennium Halls foundation consist of only spread footings for the ground floor load and fourteen caissons to support the tower's gravity load. Columns set directly on these caissons. A typical column of 22 inches by 60 inches extends the entire height of the tower. Each floor has a 12 inch thick slab and is cantilevered outward from the column line 15 feet. Lateral forces in the tower are resisted using a system of ordinary reinforced concrete shear walls and ordinary reinforced concrete moment frames.

After three separate studies outlined in the three technical reports, it is concluded that the Millennium Hall design is very efficient and has little room to improve. This proposal will therefore try to provide an alternate system that is equal or close to equal in the efficiency of the existing design.

A steel moment frame system will replace the existing concrete, and the curved column line will be moved to the exterior of the building, effectively removing the cantilevered floor slab. The cost and schedule will be analyzed along with strength and serviceability and will be compared to the existing structure to prove the alternate systems success.

## INTRODUCTION

Millennium Hall is the newest residence hall on the Drexel University Campus located in Philadelphia, Pennsylvania. Built among existing residence halls made from brick and stone, its dramatic glass façade makes the building stand out from the surroundings. The building's contrast also comes from its unique shape, a slender tower appearing to spiral upwards. This was accomplished by offsetting each floor about the building's central core by 10 inches, creating a bold statement for the university. Millennium Hall symbolizes Drexel's commitment towards the future and embraces their great history of engineering and architecture.

Required to house 482 students, the building's main design came from its main constraint, the 20,000 square foot site. Originally a lot containing 3 tennis courts, Millennium Hall had to rise upward, reaching 17 stories. The ground floor takes up most of the lot and contains the main lobby, elevator bank, reception area, a small lounge, offices and storage space. Attached to this base is the tower, where all of the student living facilities are located. Each floor includes 16 two person dorm rooms, individual shower and restrooms, shared kitchen and a study space. The 17<sup>th</sup> floor is a study lounge providing unobstructed views of the campus and the city skyline of Philadelphia. All of this is achieved in the tower's compact 5,000 square foot layout.



The majority of the building is clad with a combination of a glass and aluminum. These reflective surfaces catch the light and reflections off the neighboring buildings, quickly catching and drawing your eye towards it. The curtain wall allows maximum natural light to enter the dorm rooms and providing pleasing views for the students. Aluminum rain screen panels give the building a unique look and provide enough cover to the curtain wall to achieve an acceptable level of privacy to the rooms. These panels also work as solar shades, further reducing the building's cooling load.

The structural system for Millennium Hall uses two main types. A steel frame holding a slab on metal deck forms the ground floor and supports a green roof over the office and storage area. The tower is comprised of a cast in place concrete flat plate system. Two radial lines of concrete columns circle the central core and provide all of the strength for the tower. These columns extend the entirety of the building. Beams were then added between the columns to provide torsional strength for the slab. Each floor slab is then cantilevered outward 15 feet to the exterior of the building. Lateral forces are resisted by ordinary concrete shear walls in one direction and ordinary concrete moment frames in the other.

## STRUCTURAL SYSTEM

### Foundation Design

A geotechnical Report was prepared by Pennoni Associates, Inc. on March 12<sup>th</sup>, 2008. It concluded with the following:

- Spread footings and continuous wall footings shall be designed for a net allowable bearing pressure of 6 KSF.
- Drilled piers (caissons) shall be designed for a net allowable bearing pressure of 60 KSF.

With the absence of any sub grade levels, the Millennium Halls foundation consist of only spread footings for the ground floor load and fourteen caissons to support the tower's gravity load. (See Figure 1.1)

Below is a layout of the basic foundation elements for the tower. The drilled caissons are represented as red circles and the outline of the grade beams are shown in blue.

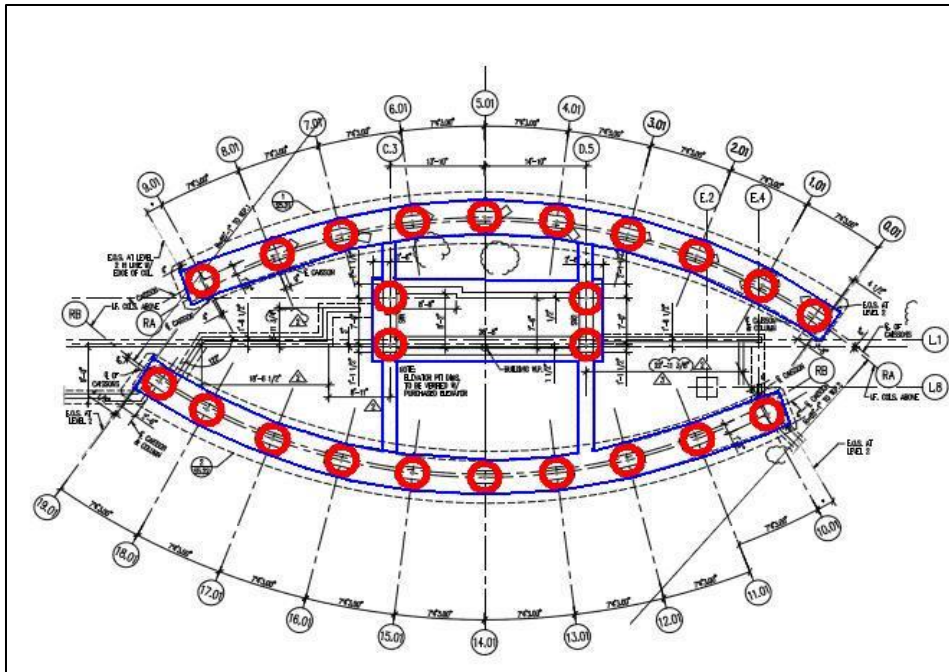

Figure 1.1

These caissons, spaced approximately 10 feet apart, are 5 feet in diameter, giving each one a bearing strength of 1200 Kips. (See Figure 1.2) Running along the line of these caissons is a 30 inch by 60 inch grade beam, reinforced with 4 - #8 on the top and bottom and #5 stirrups spaced at 12 inches. (See Figure 1.3)

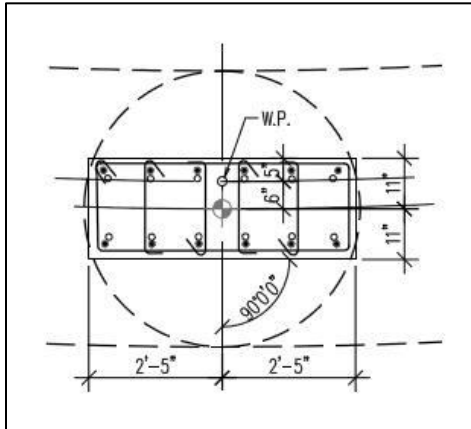

Figure 1.2

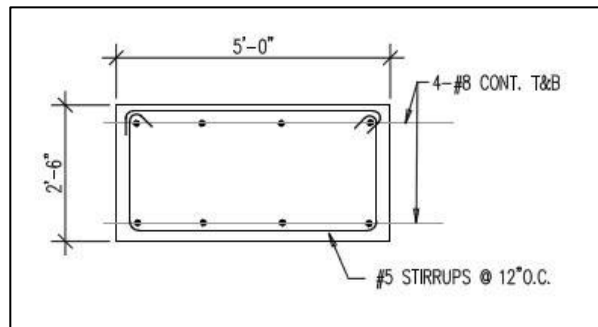

Figure 1.3

The towers twenty reinforced concrete columns sit directly on top of the perimeter caissons and are tied together with grade beams using #5 stirrups at 12 inches on center. This grade beam continues through the building as spread footings to provide strength for the first floors steel structure. The remaining four caissons located towards the center of the building at the elevator core are used to secure the reinforced concrete shear walls. These shear walls are connected to the grade beam and caisson in a way similar to the column connections. (See Figure 1.4)

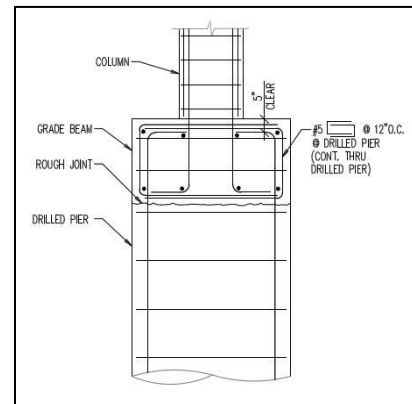

Figure 1.4

## Column Design

The millennium Hall's tower is supported by ten concrete columns which circle around the core. This typical beam is 22 inches by 60 inches and extends the entire height of the tower. Each column is directly supported by one of the foundations caissons.

## Floor Framing System

Each floor slab is cantilevered outward from the column line 15 feet. This 12 inch slab is reinforced in the east west direction with #4 bar spaced at 18 inches top and bottom. #6 bars spaced at 20 inches on the bottom and #7 bars at the top spaced 7.5 inches reinforce the north/south direction. A typical slab connection to both the column and beams between columns can be seen below. (See Figure 2.1/2.2)

The slab located between the column lines is 14 inches thick and is reinforced with #4 bar spaced at 15 inches top and bottom in the east/west direction and #4 bar at 18 inches on the bottom in the north/south direction.

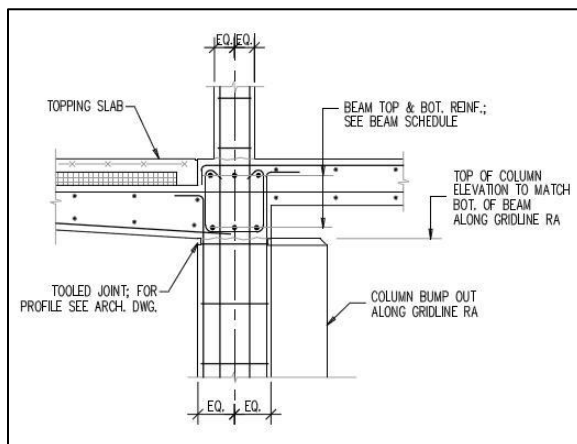

**Figure 2.1**

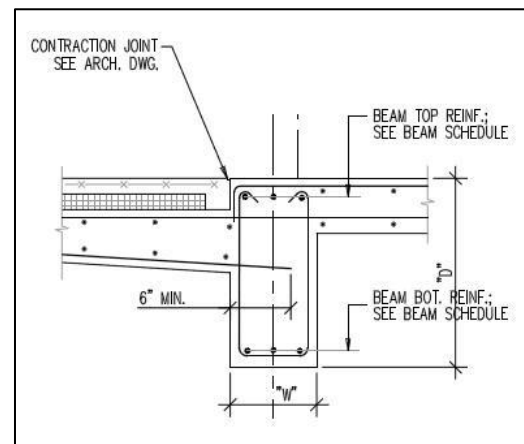
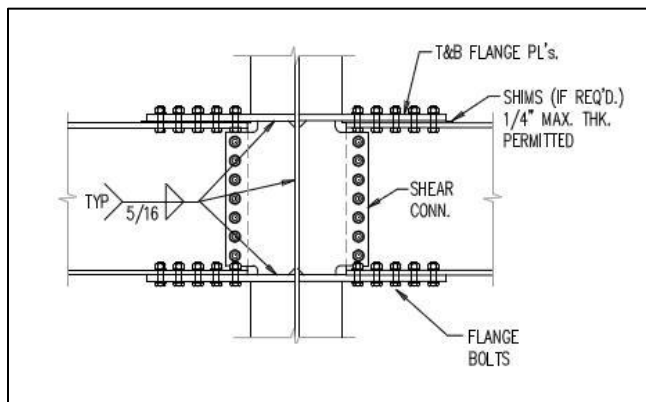

**Figure 2.2**



## Lateral System

Lateral forces in the tower are resisted using an interactive system with ordinary reinforced concrete shear walls and ordinary reinforced concrete moment frame. The shear walls are located at the center of the building in the elevator core, reinforced by splicing a series of #11 steel rebar. (See Figure 3.2) All shear walls from the ground floor to the fourth floor support a compressive strength of 7000 psi. From the fourth floor upward 5000 psi concrete is used. On the ground floor's steel frame, a steel moment connection is used. (See Figure 3.1)



**Figure 3.1**

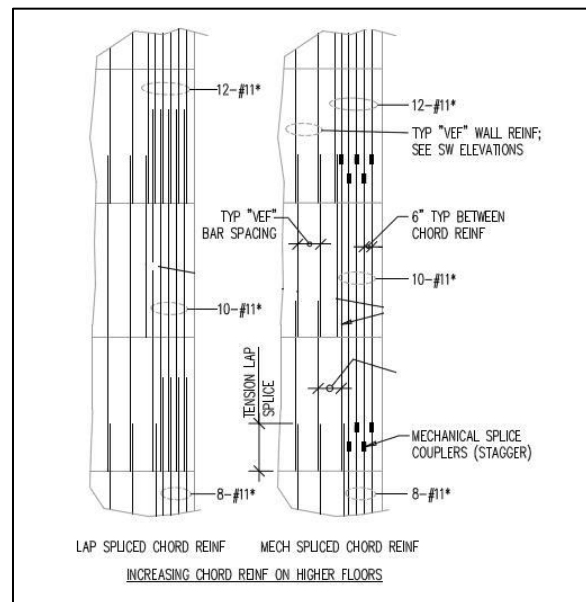

**Figure 3.2**

## Envelope Support

The building's curtain wall and aluminum rain screen panels are connected in two main ways to the building structure. On the first level the wall hangs from the slab on metal deck assembly that is supported by the ground levels steel frame. This is accomplished with 10 gauge metal plate that has been bent.

The plate, which runs continuously along the wall, is secured to the slab on metal deck using shear bolts and is reinforced with 4 foot #4 spaced at 12 inches and fastened to the curtain wall with screws placed at 12 inches. (See Figure 4.1) This bent plate runs continuously along the face of the slab.



The second type of connection is found on the tower where shear bolts embedded into the concrete slab support the curtain wall as well as the aluminum rain screen panels. These bolts connect directly to tabs specified by the curtain wall manufacturer. The slab edge is reinforced with #3 hoops spaced at a minimum of 3 inches that extend 2 feet into the slab. (See Figure 4.2)

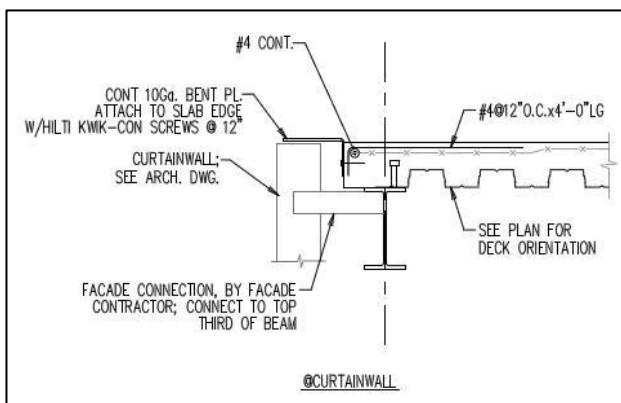

**Figure 4.1**

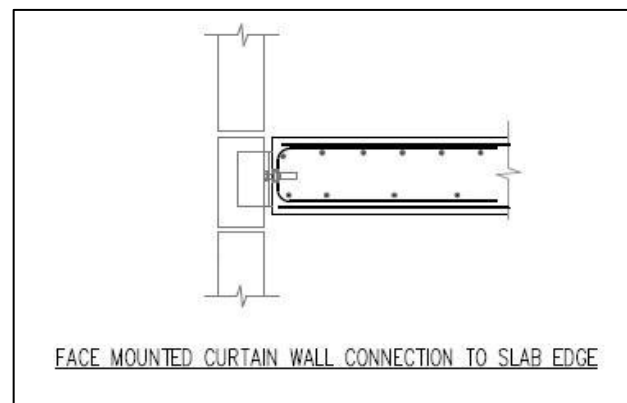

**Figure 4.2**

## PROBLEM STATEMENT

Three structural system studies have been completed for the Millennium Hall building. Separate analyses on the lateral forces, lateral resisting systems, and alternate gravity systems have shown the Millennium Hall design is very efficient. The flat plate floor slab works well with the unique floor plan and curved column line. It also provides adequate strength for the cantilevered section of floor while still maintaining a shallow floor system depth, keeping the overall building height to a minimum.

In Tech Report I, the design of the framing members, floor system, and lateral system all exceeded the design requirements for ASCE 07. In Tech Report II, the flat plate system proved to be the most efficient and effective of the four floor systems analyzed. Tech Report III proved that the lateral force resisting system of the reinforced concrete moment frames and reinforced concrete shear walls were sufficient to carry the controlling lateral loads. Because of this successful and efficient design, the final alternate system proposed may not be the best. This proposal will try to find a design that is almost as efficient to prove that there are always options to consider when designing a structure such as Millennium Hall residence building.

To determine if an alternate proposed design is successful, it will be compared to the existing structure through many aspects, including strength, serviceability, cost, scheduling and architectural success.

## PROPOSED SOLUTION

The proposed solution for the Millennium Hall building is to move the existing column lines to the exterior of the building. This will allow the building to be redesigned using a steel frame with composite steel deck. This will affect the buildings architectural design and the cost and schedule for the structural system.

### Structural Depth

The existing floor system experiences high moment forces due to the 15 foot cantilever that extends around the perimeter of the building. To try and reduce these loads while maintaining the same building floor plan, the column line will be moved to the exterior eliminating the cantilevered floor slab. This will increase the overall span by 15 feet but with the small footprint the building has, this increased span will be 35 feet, which can be safely designed with steel.

To help with this span, a concrete composite steel deck will be used, which after being analyzed in Tech II, will provide the strength required while keeping the floor system thickness to a minimum, which will be necessary with the 18 story building. The interior end of this floor system will be supported with a second added column line which will frame out the elevator core. Short girders between these will allow the long span girders to be attached while at the required 7 degree angle. (See Figure 5.1)

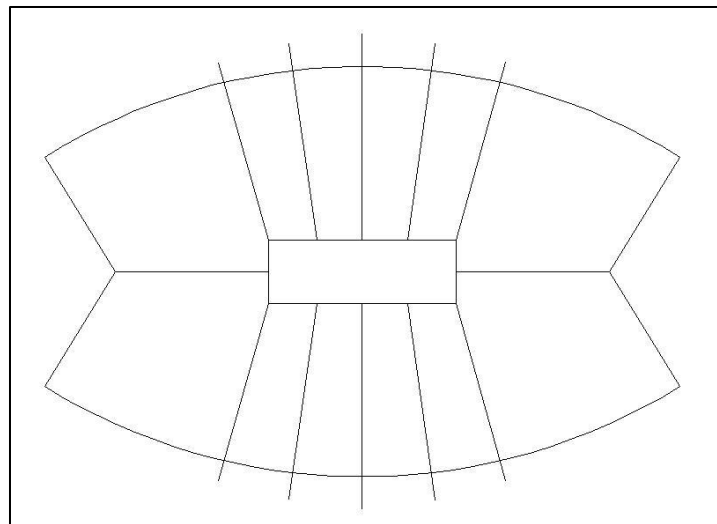

**Figure 5.1**

These short girders and exterior beams will be connected to the column using steel moment connection. Using limit states learned in AE 534, Steel Connections, the required forces will be checked to ensure the connection can be built. This will create the steel moment frame. The elevator core will still need to be used as shear walls in the North/West direction since the moment frame will provide most of its resistance in the East/West. Results from Tech Report III concluded that the steel moment frame would be sufficient in the North/West but the reduced stiffness in the other direction will require this reinforced concrete shear wall. Since both steel and concrete will be used to resist lateral forces, the interaction of the two together will be evaluated for the most efficient use of both.

## SOLUTION METHOD

To analyze the new system, gravity loads will be defined according to ASCE 7-05 and applied to the overall structure. From these loads, the slab and girder sizes can be calculated. The gravity loading cases can then be determined and applied to the columns as story forces. These forces will be calculated down the building to appropriately size the columns.

The new total building weight can then be calculated and used to determine the new lateral forces due to seismic forces. The two lateral forces, wind and seismic, can then be applied to the building in both directions and calculated.

An ETABS model can be made to model the structure. Story forces can be applied and the required shear strength for the shear walls can be calculated. Individual forces in the steel members can be obtained to design the steel moment frame connections.

## BREADTH STUDIES

In addition to the structural depth study, two additional breadth topics are required in an area outside of the structural engineering requirements. The first study to be considered is an investigation of the existing façade and its interaction with the exterior column line. The second study will be an involved investigation of the schedule and cost of construction.

### Breadth Study I: Architectural Investigation

The exterior of the Millennium Hall building was meant to be a signature look for the Drexel Campus. It is important to consider how the look of the building will be affected when the structural system is changed. The existing building uses a curtain wall of glass and aluminum rain screen panels to achieve its unique look. This wall is attached and hung from the floor slab that is cantilevered to the exterior of the building. The spiraling effect also adds to the buildings appearance.

The proposed structural changes will require the buildings twenty columns to all be moved to the exterior of the building, while a few more columns will be added to the central core. This will allow for the main floor system's beams to be supported on both ends removing the cantilever. This column shift will directly affect the layout of the building, including the individual rooms on each level. The changed layout of the room will be analyzed to ensure the functionality of each room is maintained. The means of transportation throughout the building will also be considered, as this change may affect both hall ways and stairwells.

Besides the layout adjustment, this column change will change the exterior of the building aesthetically. To achieve the existing look, the glass and aluminum materials will remain the same. New ways of connecting this curtain wall will be analyzed since the connection will be made directly to the new exterior column instead of the cantilevered slab.

## Breadth Study II: Construction Management

Changing materials from concrete to primarily steel will change the cost and schedule of the structural system. Cost data for the proposed structure will be compiled along with an approximate building schedule and will be compared to the existing structures data. The cost due to this new schedule will also be considered and compared.



## TASK AND TOOLS

### 1. Structural Depth

#### a. Steel Framing

- i. Task 1 - Determine loads applied to steel members
- ii. Task 2 - Model gravity structure in ETABS
- iii. Task 3 - Spot checks with hand calculations

#### b. Lateral System

- i. Task 4 - Determine lateral loads
- ii. Task 5 - Design shear walls using ETABS
- iii. Task 6 - Confirm steel moment connection design by hand

### 2. Architectural Breadth

- i. Task 7 - Research existing architecture
- ii. Task 8 - Analyze column line impact
- iii. Task 9 - Design curtain wall connections

### 3. Construction Management Breadth

- i. Task 10 - Determine cost and schedule of existing system
- ii. Task 11 - Determine cost and schedule of proposed system
- iii. Task 12 - Compare both systems

### 4. Presentation

- i. Task 13 - Prepare presentation