

Thesis Proposal



Three PNC Plaza
Pittsburgh, PA

R. Bryan Peiffer

The Pennsylvania State University

Architectural Engineering

Structural Option

Faculty Adviser: Dr. Ali M. Memari

December 10th, 2010

TABLE OF CONTENTS

EXECUTIVE SUMMARY	2
INTRODUCTION	3
STRUCTURAL SYSTEMS.....	4
Foundation	4
Floor System.....	6
Columns	6
Lateral System.....	7
Roof System	8
PROBLEM STATEMENT	8
PROPOSED SOLUTION	8
SOLUTION METHOD	8
BREADTHS TOPICS	9
TASKS AND TOOLS.....	10
CONCLUSION	10
PROPOSED SCHEDULE	11

EXECUTIVE SUMMARY

The current gravity system utilized in Three PNC Plaza is a composite system with a typical bay size of 30'-0" x 42'-6". The composite slab is composed of 2" 18-gauge metal floor deck with 3-½" light weight concrete, netting a total thickness of 5-½". The composite deck transfers its load to fill beams that are placed at 10'-0" on center and primarily W21X44 beams with W24X62 girders. The lateral forces from the building are resisted by concrete shear walls located throughout the core of the building along with the steel moment frame surrounding them. This system overall is an excellent design for the building to accomplish what the owners and architects wanted for the building.

The proposed thesis for Three PNC Plaza will be to redesign the current building using concrete as the main material of construction. This will require a new design to the gravity system which may result in altering the current layout of the building. However, if a Two-Way Post Tensioned slab is found as an applicable solution the large spans could still be achieved. This design alternative is being proposed to gain a better understand and more experience in concrete design. The proposed design for Three PNC Plaza has the potential to lower the depth of the existing floor system resulting in a greater floor to floor height. Switching from a lightweight concrete composite system to concrete system will increase the building weight resulting in significant changes to gravity and lateral loads placed on the building. The lateral system for the building will have to be reexamined and changed to deal with the updated loads.

The breadths topics being proposed for this thesis will be a Construction Management breadth, and an Architectural Breadth. From a Construction Management prospective changing the structural system to concrete will have dramatic effect on the cost of the building and the construction schedule. Because of this a new schedule will be proposed along with a new cost estimate for the structural system. The second breadth topic will revolve around the architectural changes required to the building from the new concrete system. The current layout of the building will most likely have to be altered to work with the new concrete structure. These changes will be explored to see the impact they have on the current building layout.

INTRODUCTION

Three PNC Plaza is a 23 story, 780,000 square foot, mixed use high-rise building located in the heart of downtown Pittsburgh, Pennsylvania as seen in figure 2 highlighted in red. The erection of this building was a significant part to revitalizing the downtown area and marked the first new high-rise built in the city in the last 20 years.



Figure 1- Three PNC Occupancy Layout

The building is mixed-use and allows for several different tenants occupy the building as seen in figure 1. Fairmont Hotels and Resorts move into the building in March, 2010 with 185 rooms that are located on floors 14 through 23. Along with the Fairmont Hotels, 28 Residences condominium units will occupy floors 14 through 23 in the fall of 2010. The building has 10 floors of office space located from the 3rd through 13th floor. These office spaces are home to PNC Bank and the REED Smith Law Firm. The lower floors of the building house several different retail stores, restaurant, and wine bar.

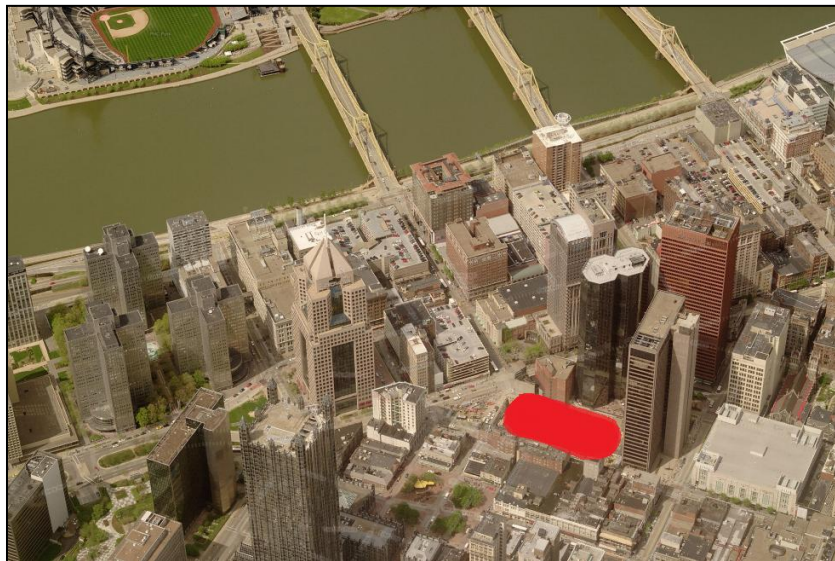

Figure 2- Three PNC Site Location

STRUCTURE OVERVIEW

Foundation System

Pittsburgh is known for alluvial deposits which mean shallow foundations were not possible and deep foundations were required for Three PNC Plaza. Also, the Pittsburgh area soil overburden is 60' to bedrock. This means that after the 30' of excavation for the buildings parking garage structure, 30' of soil would still remain until the bedrock would be

reached. Several different options for the foundation of the building were considered such as; auger cast pile, piles, H-piles, and caissons. Ultimately, the foundation system chosen for Three PNC Plaza were caissons bearing on bedrock to achieve maximum axial capacity. Four different size caissons were chosen for the foundation as seen in the Caisson Schedule in figure 3. The caissons were

CAISSONS $F_{BR.} = 30K/SQ. FT.$				
MARK	SIZE \varnothing	VERT. REINF. length=3 X DIA.	TIES	DOWELS
A.	48"	7-#10	#4@18" O.C.	4-#8 X 8'-0" DEVELOP INTO PEDESTAL
B.	54"	9-#10	#4@18" O.C.	
C.	42"	7-#9	#3@18" O.C.	
D.	60"	9-#11	#3@18" O.C.	

Figure 3- Caisson Schedule

designed for a typical column reaction of 3500 kips. Brayman Construction Corporation was in charge of the installation of the 121 caissons for the building. A typical caisson detail has been provided in figure 2. The caissons bearing value is 15 tons per square foot and were drilled to auger refusal or socketed into the bedrock. The layout for the caissons can be seen in figures 5 and 6 located on the next page.

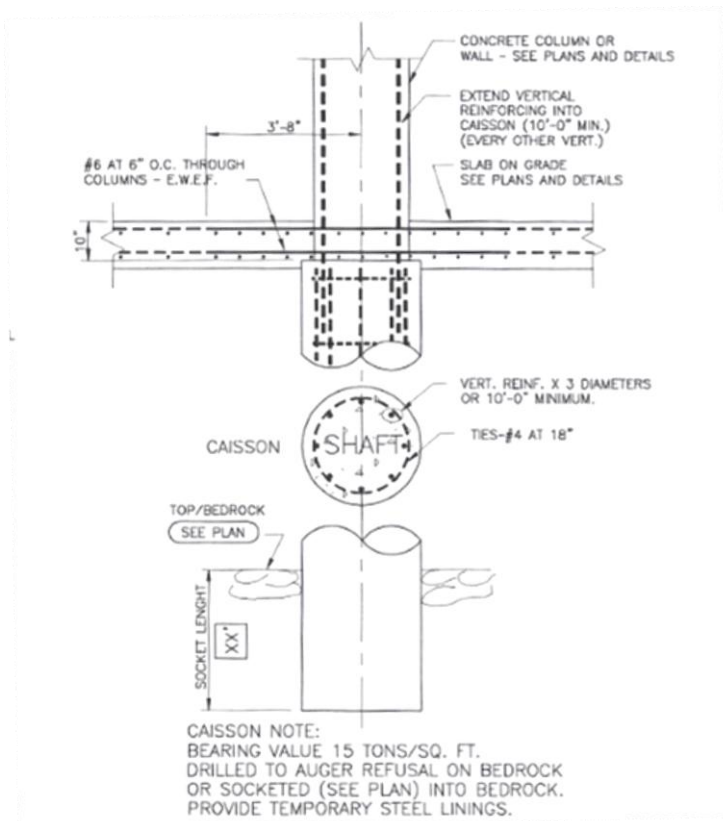
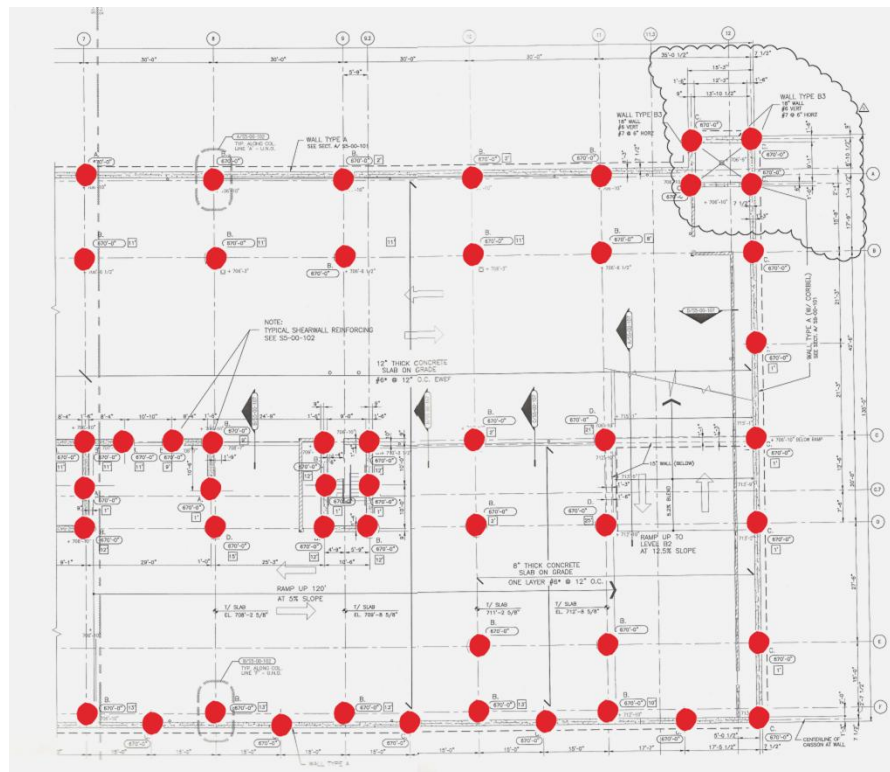
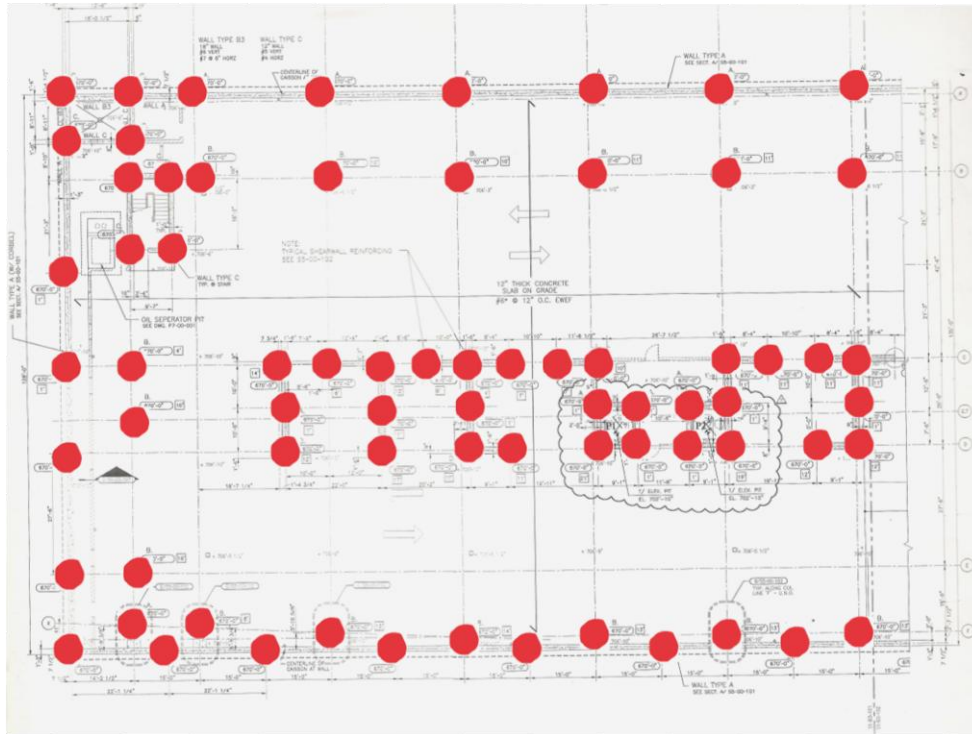
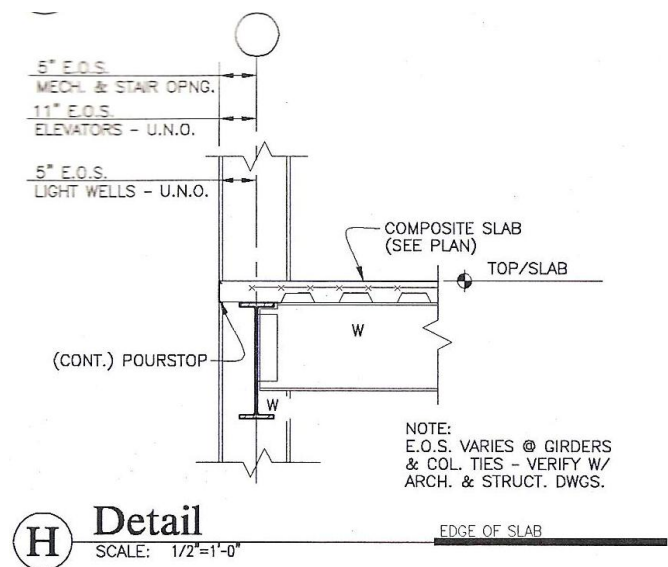

Figure 4- Caisson Detail



Floor System

Three PNC Plaza uses a composite steel and concrete floor system with a typical bay size of 30'-0" x 42'-6". The composite slab is composed of 2" 18-gauge metal floor deck with 3-1/2" light weight concrete, netting a total thickness of 5-1/2". The concrete is reinforced with one layer of 6x6-W2.1xW2.1 welded wire fabric. The composite deck transfers its load to fill beams that are placed at 10'-0" on center and primarily W21X44 beams with W24X62 girders. This floor design is used throughout the structure and different sized fill beams are used to deal with higher load areas.



Columns

Three PNC Plaza uses a variety of steel columns and concrete shear walls to support the gravity load of the building. The size of these columns can range in sizes from W14x68 all the way to a W14x740 in some cases. The core of the building is supported by concrete shear walls up until the 14th floor which they then switch over to steel columns. The remainder of the building is supported by steel columns from the ground floor that attach to concrete columns located in the parking garage. The steel columns attach to the concrete shear wall via reinforced corbels. The steel columns in the building are spliced together at a typical distance of 24'-0" as see in figure 8.

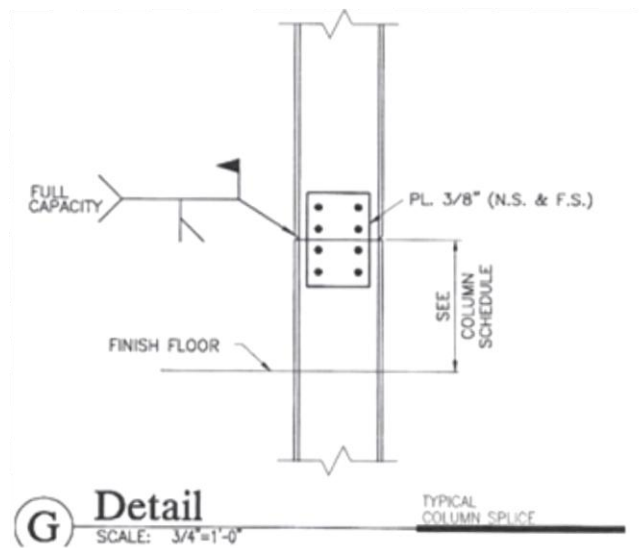

Figure 8- Splice Detail

Roof System

The main lateral resistant system used in Three PNC Plaza is a combination of several concrete shear walls. These shear walls are located throughout the core of the building and encase the stairwells and elevators as seen in figure 9 highlighted in red. The shear walls start at the lowest level of the parking garage structure and extend up until the 14th floor where they are met with steel columns. All of the shear walls used a concrete with a compressive strength of 5000 ksi. The reinforcement for the shear walls changed depending on the location and can be seen in the shear wall Reinforcement schedule located in Appendix D. A more detailed view of the shear walls at key locations of the wall can be in figures 10-13. Once the building rises above the 14th floor the steel structure assumes the responsibilities for the lateral loads. The main lateral resisting system located above the shear walls could not be determined from provided plans. Information has been requested to investigate this further.



Figure 9- Shear Wall Layout

Roof System

The roof structural system is very similar to the floor structural system used throughout the building. It utilizes the same composite deck and slab configuration along with same typical bay dimensions. However, the fill beams are spaced closer together, at a typical spacing of 7.5 feet. These fill beams can differ in size from a W21x44 to a W27x129.

PROBLEM STATEMENT

The existing structural system for Three PNC Plaza consists of concrete shear walls and a steel moment frame with a lightweight concrete composite decking system. It was found throughout technical reports 1 to 3 that the current system used in the building is most likely the optimal design for the building. Therefore, when exploring alternative systems to be used for the building, they may not result in the most effective system to be used for the building. However, it is being proposed to change the current system in the building to one that utilizes only concrete material. The change to a concrete material could reduce costs depending on which system is utilized and provided a smaller floor depth.

PROPOSED SOLUTION

Research from Technical Report #2 provided insight into what systems would be valid alternatives for the building. It resulted in the Two-Way Post-Tensioned slab being the front runner from a concrete system stand point due to its ability to span long distances. However, a further investigation into the system will be required to see if it is an adequate alternative. The Two-Way Flat Plate system would also be another system that could be used but would require additional columns added to reduce the 42.5' spans found in the building. With the new system in place the concrete shear walls will have to be redesigned and extend throughout the entire building to provided adequate lateral resistance. Due to the increased weight of the building loads will have to be reexamined for both gravity and lateral. The new system will then be compared to the current system to see the strengths and weaknesses or each.

SOLUTION METHOD

The first step for this process would be to further research the Two-Way Post-Tensioned system to make sure it is a valid solution for the building. Once, the main system is picked it will have to be designed for the current layout of the building. After the design is complete a 3D ETABS model will be constructed to determine the loads developed from the new system. Then the columns can be designed to meet the loads determined from the 3D model. Finally, once all of the gravity members are designed the lateral loads will be applied and to determine the design for the lateral system.

BREADTH TOPICS

Breadth 1

Since a new structural system for the building is being proposed the cost and schedule of the building will have to be altered. A structural estimate for the building will be performed for the new design along with a new construction schedule. These documents will then be compared to the original building cost and schedule.

*Original schedule has not been obtained. This will require me to reach out to my contact to see if they will provide me with one over the Holidays.

Breadth 2

The second breadth topic that will be studied is the architectural impact the new system will cause on the building. The new shear walls will be examined and see how they impact the current layout of the building. Also, if the Flat Plate system is used columns will have to be added to the building dramatically changing the current layout.

Tasks and Tools

Depth

1. Furth Research into Two-Way Post- Tension systems to make sure it is a valid system
 - a. This will be worked on over the Holliday break to not interfere with the schedule next semester
2. Design the concrete slab system to be used for the building
 - a. Design the optimal slab system using hand calculations, check with computer programs if applicable
3. Column Design
 - a. Find the new gravity loads and design columns
4. Evaluate Lateral System
 - a. Find new lateral loads to design the new shear wall system
5. Determine Effects on new system on foundation

Breadth 1

1. Obtain the needed information for the schedule and cost estimates
2. Estimate new cost of concrete system
3. Propose new schedule
4. Compare to existing building cost and schedule

Breadth 2

1. Review how new system changes current floor layouts
2. Check effects to the curtain wall from the new concrete system
3. Develop a modified or new Layout and Façade if needed

Conclusion

During the next semester the entire gravity system will be redesigned using concrete. These designs will be done through a variation of hand calculations and the use of computer modeling programs. Along with the gravity system the lateral system will have to be changed to deal with the new loads being placed on the structure. The breadth topics will cover the architectural impact of the new system along with the cost and scheduling changes.

Schedule

