

J.B. Byrd Alzheimer's Center & Research Institute

Tampa, Florida

January 12, 2012
Faculty Advisor: Dr. Ali Memari

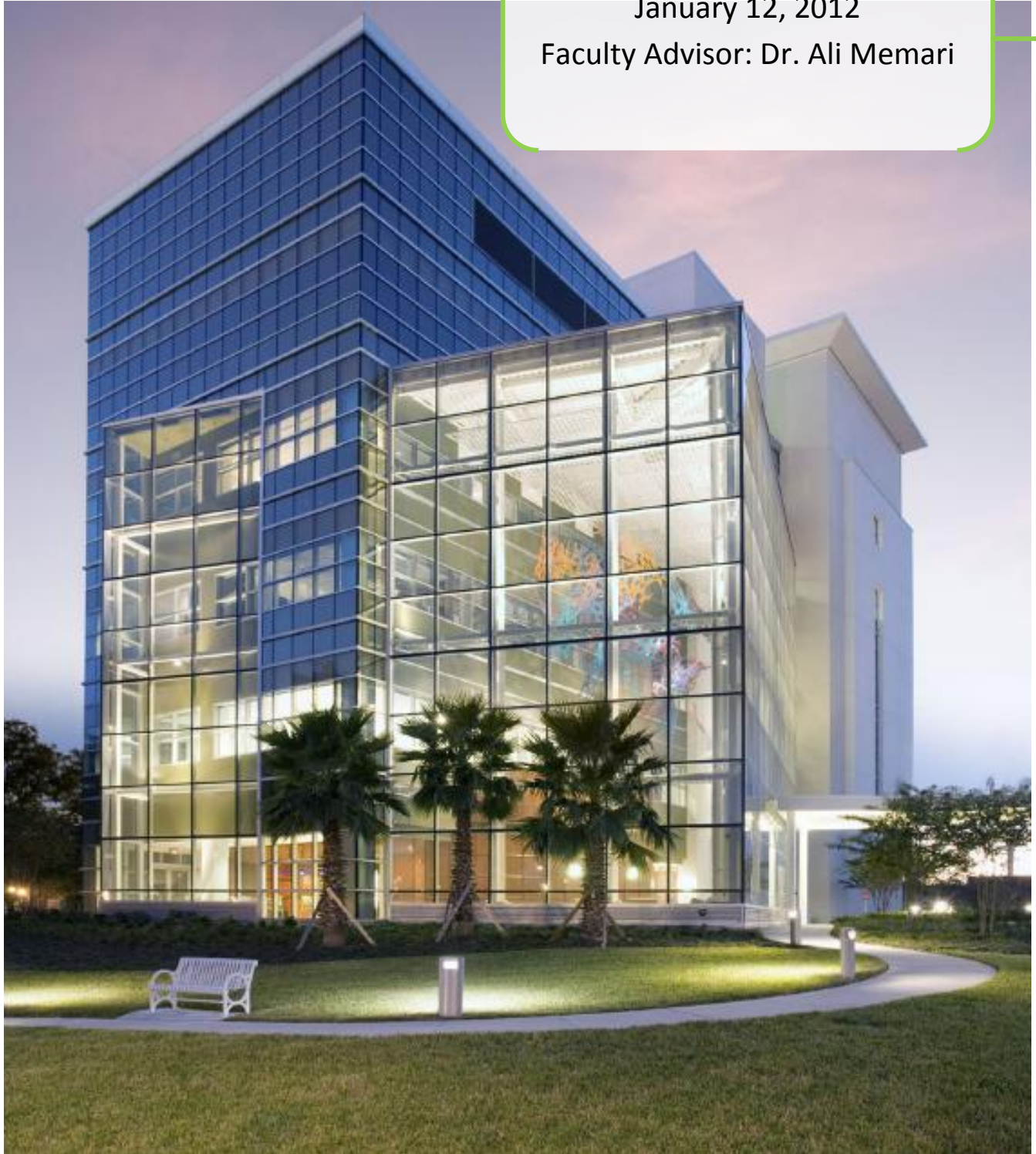

Table of Contents

Executive Summary.....	3
Building Introduction	4
Structural Overview	5
Foundations.....	5
Floor Systems	7
Framing System.....	9
Lateral System	9
Atrium Wall Framing / Floor vibration Criteria	9
Roof Systems	10
Problem Statement.....	11
Proposed Solution.....	11
Breadth Topics	12
Breadth 1: Construction Management: Cost and Scheduling.....	12
Breadth 2: Mechanical & Sustainability: Viability Study.....	13
MAE Material Incorporation	14
Method	15
Tasks and Tools	16
Schedule.....	18
Conclusion.....	19

Executive Summary

The main purpose of this proposal is to identify a challenge, propose a solution to the challenge, and outline the methods, tasks, tools, and schedule which will be used to solve the challenge for the J.B. Byrd Alzheimer's Center & Research Institute. This is a new, 108,000 square foot business, clinic and laboratory classroom building located in Tampa, Florida. The main gravity system comprises of precast joists and beam soffits with cast-in-place one way slab. The lateral system is a dual system consisting of 11 shear walls located around vertical shafts and of concrete moment frames scattered throughout the building.

As it is originally designed, the J.B Byrd Center has very few structural challenges. Therefore, a scenario has been created where the University of San Diego (USD), has requested the design of an identical building. It is of interest to the designer to incorporate performance-based design, and therefore the proposed solution will meet the ASCE 41-06 seismic drift and damage criteria. The proposed solution offers two comparable structural concrete frames: one which is designed as a traditional cast-in-place concrete dual moment frames and shear walls, and a second which is designed as a traditional cast-in-place concrete dual moment frames and shear walls augmented with base isolators to dampen the effects on the building. The same geotechnical report will be used for all design at the San Diego, CA site since no information was received on the (USD) campus.

The design will follow a logical progression. First, a cast-in-place gravity frame will be developed for the current location (Tampa, Florida) for comparison purposes. Then another will be designed in San Diego California to compare between the required lateral system for a seismic and non-seismic region. The later will be serving as the basis comparison for the two proposed solutions. Then, a base isolation frame will be designed in San Diego, CA location to serve as comparison for the previous solution. Finally, the base isolation system will be optimized to meet the performance of the first solution to deem not only how base isolators affect a building but what is more efficient in cost and scheduling.

In addition to this structural depth, two breadth studies will also be conducted. The first will be a construction management breadth which will consist of a schedule and a detailed cost analysis for the concrete structural systems which will be designed. This will assist in the comparison of the precast joists and soffit beam system. A sustainability breadth will also be undertaken which will assess the viability of adding solar photovoltaic glazing to the curtain wall facade. Practicality of the systems will be determined based on cost of the system, savings as a result of using the system, additional LEED points, a life cycle assessment, and a payback period.

The MAE coursework incorporated into the proposed designs, the methods through which these designs will be achieved, the tasks required to complete them, and the tools which will be used are also discussed in this proposal. Finally, a schedule is enclosed to ensure work will be completed by the deadline.

Building Introduction

The Johnnie B. Byrd, Sr. Alzheimer's Center & Research Institute or J.B Alzheimer's center is located in Tampa, Hillsborough, Florida in the University of South Florida's campus. It's located on the intersection of the orange lines on Fletcher Avenue and Magnolia Avenue (See Figure 1). Its occupant is the University of South Florida and it is a business occupancy used for offices and as a research facility. In fact, after its

construction the Florida Alzheimer's center and Research facility became one of the largest freestanding facilities of its type in the world specifically devoted to this illness. It is designed to primarily function as a research unit with labs, a hub for clinic trials, and a data collection center for all Alzheimer facilities throughout the state of Florida. It is built on a 2.6 acres site and the size of the building is 108,054 sq. ft., gross. It is 9 stories including a basement totally a height 106'10". The actual building cost was \$23,602,477. It has been LEED silver accredited after construction. From start to finish the construction dates were from February 7, 2006 to July 9, 2007 hence about a year and a half.

The Owner/Client of the project is Johnnie B. Byrd Alzheimer's Center & Research Institute. The General Contractor + CM were Turner Construction Company. Everything else (i.e. Architecture, Structural Engineering, Mechanical & Electrical & Plumbing Engineering, Civil Engineering, Landscape Architecture, Security & Telecom) were handled by HDR Architecture, Inc. This project was delivered to the owner by a design-bid-build method.

The façade of the building is mainly divided into two parts. The east side consist of curtain wall glazing and Aluminum panels. The west side consists of cement plaster with the same curtain wall like glazing and decorative grille with louver at the top. As for the roof the use of Thermoplastic Membrane roofing was chosen with $\frac{1}{4}$ " per foot slope with Aluminum parapet for architectural reasons.

Magnolia Ave.



Fletcher

Figure 1- Site Location on campus of USF

Structural Overview

Basic construction materials of the building include stone column piers and a spread footing foundation system with below grade footing. The structure is composed of precast joist webs and soffit beam bottoms with concrete shear walls. Exterior walls are constructed of cement plaster and lath on steel stud back up framing. The curtain wall system has a kynar aluminum finish and integrates several glazing types. Mechanical systems include packaged air handlers, on-site chillers, and gas fired boilers.

Initially, HDR Architecture Inc. structural department had designed this building as a composite system composed of steel beams, flanges, columns and a concrete slab on metal floor deck. They had their system pre-designed with specifics. However, all these ideas got tossed away when the Owner and the Contractor decided to use a more economical and efficient concrete system with precast joist webs and soffit beams. The latter exists mainly in Florida. Hence, the use of it will be fairly new to others, which add uniqueness to this building and thesis.

The J.B. Byrd Alzheimer's Center & Research Institute rests on spread footings for columns and continuous strip footings for walls as well as a mat slab foundation system. This was advised by Nodarse & Associates, Inc. because the site lies on a potential sinkhole activity. The lower 7 floors utilize a one way concrete slab with precast joist ribs and soffit beam framing system for floor framing with cast in-place columns. Part of level 7 and level 8 still utilize the same floor framing but with larger spacing as well as concentrated reinforcing bars around roof anchors. The lateral system consists of moment frames with concrete shear walls around the main openings.

The importance factors for all calculations were based on Occupancy category II. This was chosen because the J.B A.C. & R.I. falls under office building.

Foundations

Nodarse & Associates, Inc prepared a report of Preliminary Geotechnical Exploration for this project. The subsurface exploration consisted of a Ground Penetrating Radar (GPR) survey on the site and eight Standard Penetration Test (SPT) borings to depths of 50 to 75 feet below existing site grades.

The borings encountered a relatively uniform subsurface profile consisting of the following respectively with depths: clean sands, medium dense clayey sands, very soft to stiff clays, and weathered to very hard limestone formation. There are indicators in the borings that correlate with the increased risk for sinkhole occurrence. These indicators consist of very soft soils or possibly voids. They estimated that sinkhole could range at the ground level from 10 to 25 feet across. A deep foundation system was not recommended due to the possibility of damage to other adjacent structures from pile-driving vibrations. Also, a cast-in-place deep foundations such as auger cast piles or drilled shafts are not recommended because the presence of joints, fissures, soft zones, and voids within the limestone formation and overburden soils will result in excessive overages of concrete and the need for permanent steel casing. In addition, The University of South Florida expressed concerns about this method as there is the potential of water contamination.

Hence, Nodarse & Associates, Inc recommended, based on their findings the use of a vibro-flotation/stone columns to improve soil conditions so that the building can be supported on a shallow foundation system such as footings and mat slabs (see figure 3 for shallow foundations used). The vibrating probe is intended to pre-collapse potential sinkholes (a total settlement of 1 inch or less) to reduce the possibility of future development. After the dry bottom, stone columns (42" +/- diameter) were installed to a depth of 25 feet. The stone columns were recommended to be crushed stone aggregate a similar gradation to FDOT No. 57 stone. Footings were then designed on a maximum allowable bearing pressure of 6,000psf. The allowable soil bearing capacity is 10,000 psf after soil improvement. Minimum footing widths for columns and wall footings of 36 and 24 inches respectively were used. Footings bear at least 36 inches below finished floor elevations to provide adequate confinement of bearing soils.

The ground water on this project site appears to be below a basement depth of 10 feet below existing grade, making a basement acceptable. Retaining Walls were also designed using a maximum allowable bearing pressure of 2,000 psi.

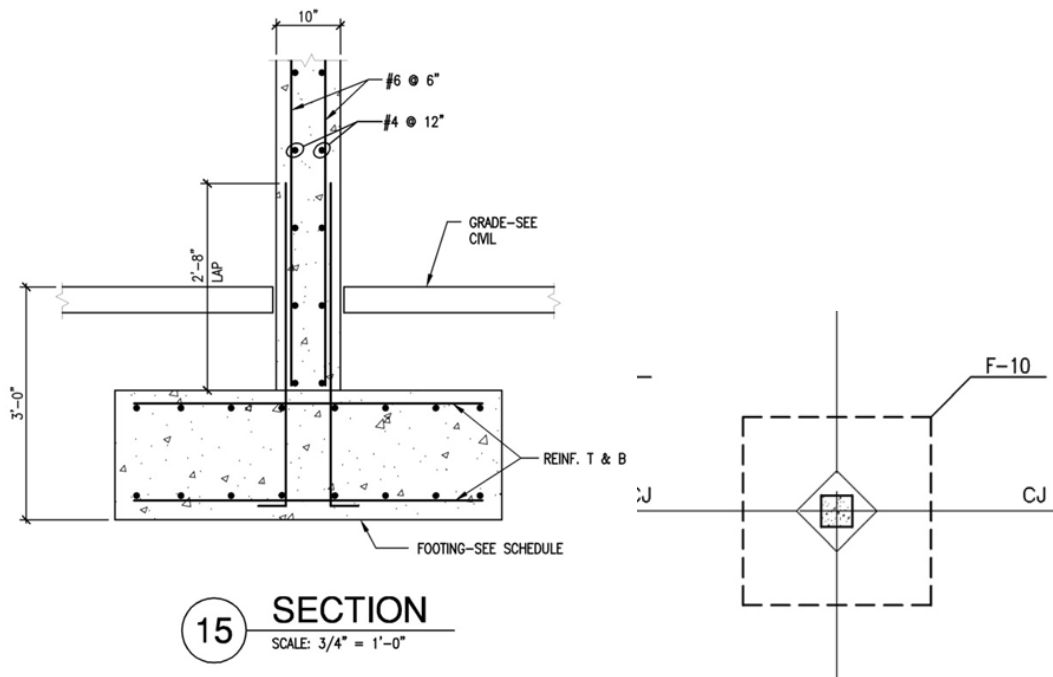

Figure 2- Foundation section and plan showing footing-column connection and size

Floor Systems

Even though this building is very architectural and seems like an irregular shape building with a complicated structure it can be divided into 4 simple sections. The sections also correspond to the different uses of the building. Figure 4 shows a typical floor plan with the different bay sizes highlighted with different colors.

All the elevated floors of the J.B AC&RI are a hybrid system consisting of a precast joist ribs and soffit beam framing system with cast-in-place to unite the system. In fact, there are 5 main joists that have respectively the following depths: 8", 12', 16", 20", and 28". The entire precast joists and beam soffits are brought on site and lifted to the positions using scaffolding and then they are tied to the structure. Once the structure is erected, the formwork and the rebar reinforcing (if needed) are done then further a 5" concrete slab is casted in place to unite the system (see figure 6). As stated before, 5 different joist depths were used adequately depending on the required spans and uses. For the approximately 40' span, a 20" or J4 was used spaced at 5'-8". That area, corresponding to the green rectangle in figure 4 is typically an office area. For the orange rectangle, where the research labs reside, a J3 or 16" spaced at 5-6" was used for a span of 31'. However in the same area, J4 or 20" spaced at 3'-6" and J5 or 28" at 3'-2" were used to accommodate the PET scans and MRI components respectively (see figure 5).

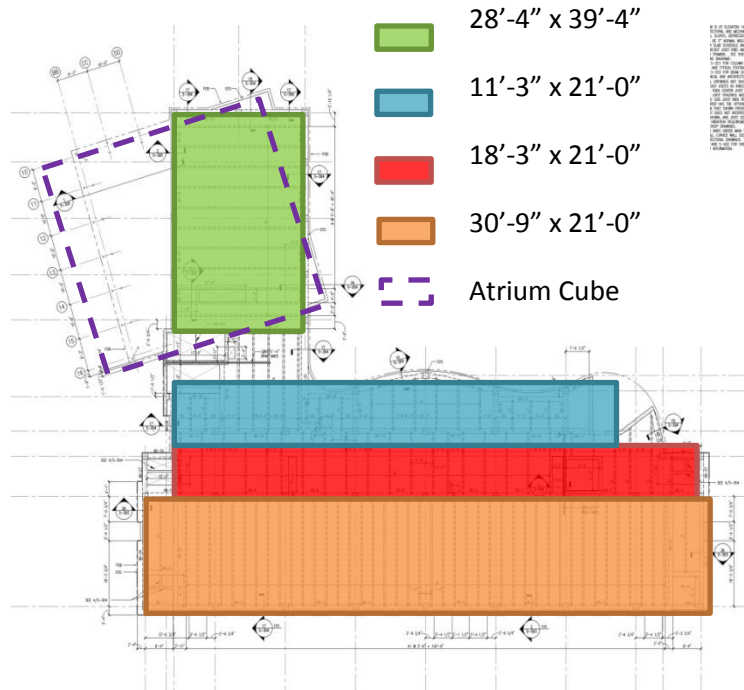

Figure 3- Floor plan showing different bay sizes

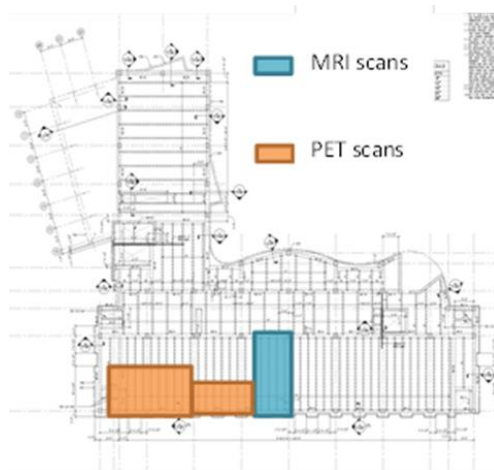

Figure 4- 2nd level floor plan showing MRI/PET scan location

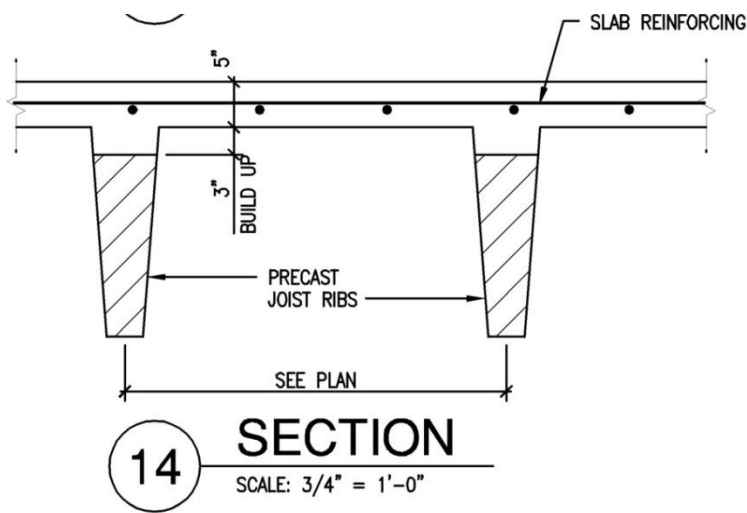
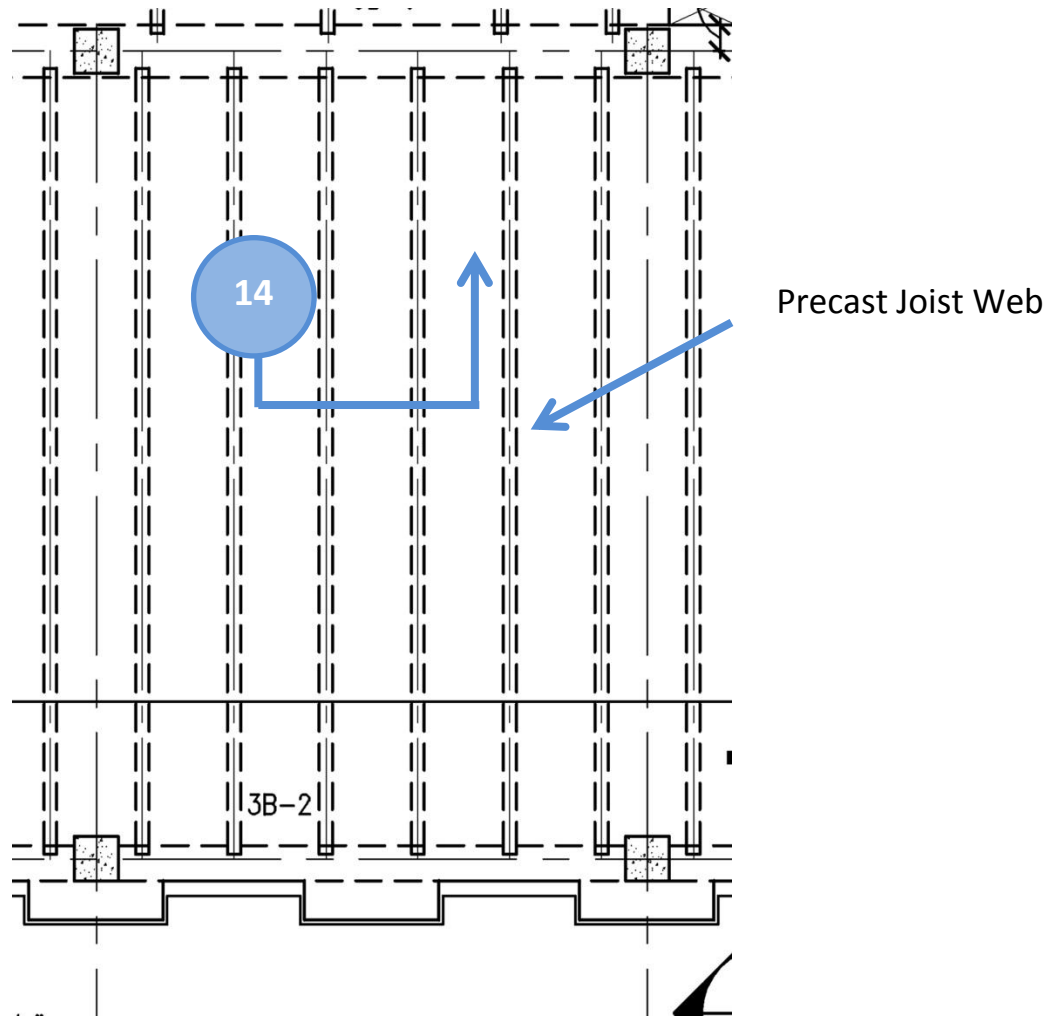

Figure 5- Plan and section of precast joists

Framing System

The columns in the lower 7 stories are all cast-in-place concrete. Most of the columns are square and have 4,000psi strength. However, the columns supporting the research labs where the heavy equipment exists and vibration criteria need to be attained a 6,000psi concrete columns were used at the basement and the first floor (see figure 7). All columns are about 20"x20" with reinforcing ranging from 4 to 8 bars except for a few exception that are 20"x30" with 16 bars.

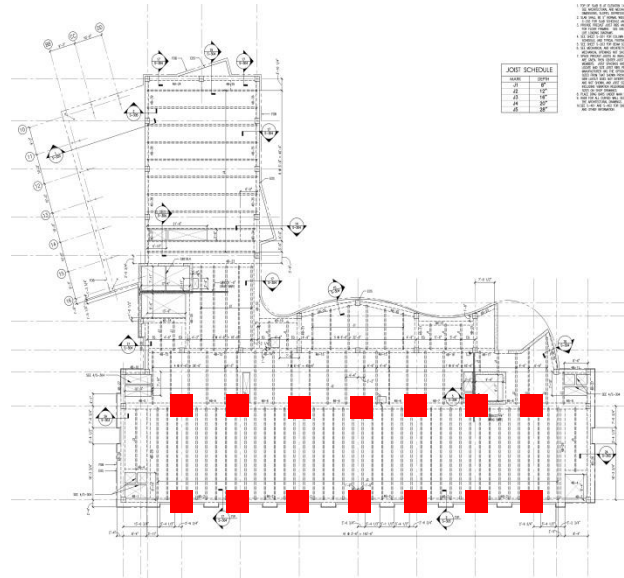

Figure 6- Floor plan showing the 6,000 psi column in basement and 1 floor

Lateral System

The lateral system is composed of concrete shear walls and moment frames. The shear walls are around the main vertical circulation at both ends of the building (see figure 8). They resist the N-S direction as well as E-W direction for best result and little torsion. All of these walls are cast-in-place and are 12" thick. All of them span from basement to the roof. They are anchored at the base by a mat slab foundation that is 3'-0" thick. An issue not investigated by this report is how much the moment frame resists the loading compared to the shear walls when loaded in both directions.

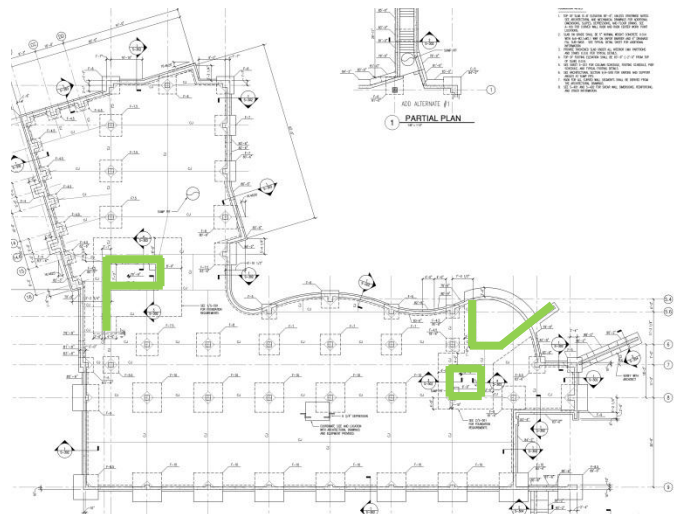

Figure 7- Floor plan showing shear walls

Atrium Wall Framing / Floor vibration Criteria

The atrium roof is approximately 60 feet above grade. Architectural trusses, approximately 36" deep are designed to support the exterior storefront glazing spanning this 60 feet. The trusses are designed to minimize deflections from hurricane force winds on this wall. The design wind speed for the area is 120mph which yields that the 50'- 60' range was designed at 31.3 PSF. Truss components are made from structural tubes (ASTM A500, Grade B of $F_y = 46\text{Ksi}$) and pipes (ASTM A53, Grade B $F_y = 35\text{Ksi}$) in this highly visible part of the building.

The vibration control design interfaces with the design of structural, mechanical, architectural, and electrical systems in such a way that those systems do not generate or propagate vibrations detrimental to research activities of the Florida Alzheimer's Center & Research. Vibration criteria have been developed based upon examination of vibration requirements of planned or hypothetical equipment. General labs make up the research facility, and the structure will be designed for vibration amplitude of 2000-4000 $\mu\text{in/s}$. This accommodates bench microscopes at up to 400x magnification. This last will play a significant role in choosing the members of the system as well as the systems themselves.

Roof Systems

There are two different roof levels: one on the seventh floor and the other on the mechanical level on top of that (See Figure 9). The figure shows a height from level 1 that starts at 100'0" but for simplicity only the true height is shown. This two roof structure consists of the same material and system as the floor system as they hold a great deal of load (mainly mechanical that include packaged air handlers, on-site chillers, and gas fired boilers). However, the slabs were heavily reinforced around the roof anchors. Level 7 has joist spacing of 5'8" in the green section and 3'6" under the red section. On the mechanical level a spacing of 5'-6" is used as loads are minimal. There is also the roof of the atrium cube that is not shown on this figure. That last is at height of 153'-9" and consists of trusses, angles, C shape and HSS bars. In addition to the atrium roof, a canopy at the entrance hangs at a height of 114'-6" and consists of W shape with a 1½" 18 Gage galvanized metal roof deck.



Figure 8- Showing the different roof levels on the building

Problem Statement

Since it is well designed, there is not much that could be done to the J.B Byrd Center that would lead to major improvements. The structural system is suitable in strength, economical and is equitable in comparison to typical alternatives. In fact, the only two realistic replacements would be cast-in-place concrete or a steel frame building as noted in Tech 2 but even then only minimal differences are produced. Thus, redesigning the building other than the systems noted previously would produce a non-feasible solution especially in its current location.

Furthermore, as the author is interested in seismic design a scenario has been created in which an identical Alzheimer's Center and Research Institute to the J.B Byrd. Center is being requested to be built in San Diego, California. To be more specific, the University of San Diego (USD) will be taken as the new campus of this building. This change in location will alter the wind and seismic forces imposing the design to be controlled by seismic instead of wind. The same geotechnical report will be used for unavailability of (USD) campus's geotechnical report and for being conservative as the current soil properties are poor.

Moreover, the scenario chosen is in contemporary with major seismic events that happened in 2011 all over the world. The earthquakes in Chile, New Zealand and Japan and most recently in Turkey, made engineers more ardent in averting catastrophes in the future. In fact, the use of typical materials and construction method will be used to design the structural system for the new building.

Therefore, a reasonable structural system must be designed to provide sufficient strength and serviceability to prevent the building from collapse after a major seismic event. The new design will be able to resist all dead, live, wind and seismic loads with little impact to architecture in order to satisfy the new owner. Nonetheless, the cost and schedule will increase.

Proposed Solution

Two concrete systems will be compared in this proposal. As this is a different construction type than the original design, the gravity system will be re-designed first. Then, the building's lateral system will be designed according to ASCE 7-05. Once all the system is designed, base isolators based above the foundations will be placed creating a different system. Thus, the following structural systems will be compared:

- A Cast-in-Place Dual System (Moment Frames and Shear Walls)
- A Cast-in-Place Dual System (Moment Frames and Shear Walls) with Base Isolators

The first solution will be a cast-in-place system chosen to fit typical construction in San Francisco. The concrete system will be designed to support the existing gravity loads. It will consist of typical sizes already used in the building using the same layout. An increase in member sizes may be needed if an alternative layout was determined to be used to fit the building's structural needs. However, the shear walls will stay intact so the architectural layout is not changed.

The second solution will be the same system as above but with base isolators above the foundations. Base isolators are a collection of structural elements which should substantially decouple a superstructure from its substructure resting on a shaking ground thus protecting the building structure's integrity. Base isolation is one of the most powerful tools to protect a building from a potentially devastating earthquake. In fact, the isolators allow the structure to respond much more slowly than it would without them, resulting in lower seismic demand on the structure. They will help on lowering deflections and cracks to both structural and non-structural components in the building. There are three main categories of base isolators: Rubber, Lead, and Steel. At this point of the proposal, the type of base isolator is undecided but mainly leaning on lead. To view such a type, please refer to the image below.

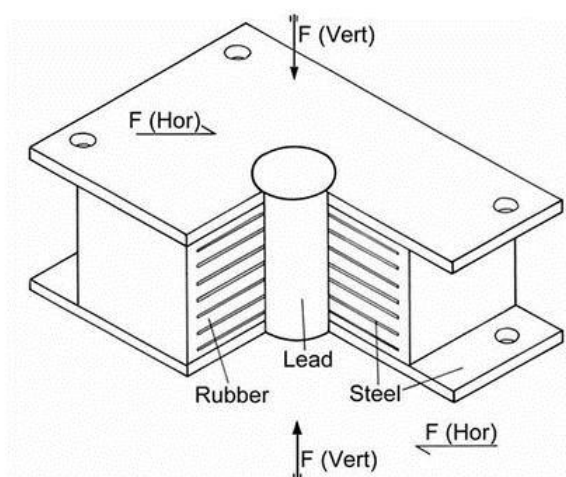

Figure 9 - Lead Rubber bearing base isolators taken from Robinson Seismic Limited

Lead might be chosen because of its plastic property. In fact, while it may deform with the movement of the earthquake, it will revert to its original shape, and it is capable of deforming many times without losing strength. During an earthquake, the kinetic energy of the earthquake is absorbed into heat energy as the lead is deformed.

Breadth Topics

Breadth 1: Construction Management: Cost and Scheduling.

The main purpose of the construction management breadth is to develop a cost and schedule for the original structure as well as both of the proposed cast-in-place structures for comparison purposes. Key comparisons will be: which system is more efficient in that area, how much additional cost results from designing a higher performance building, how much does seismic design impacts a building, what effects do base isolators have on construction and what system is more efficient from the ones proposed.

Furthermore, the comparison between the traditional cast-in-place system and the traditional cast-in-place system with a base isolation system is of particular interest. A common perception in the industry is that more technology increases efficiency. A direct cost and schedule comparison between the

traditional and high-tech systems of equal or greater performance will either support or disprove this belief. If time permits the structures will be designed to equal performance levels, the structure which is able to be constructed more quickly and at the least cost will be deemed the most efficient. However, if time did not permit, the study will be focused on how base isolators do affect a building's performance for the author's interest.

The schedule analysis must be performed first, as some items in the cost are dependent on construction duration. Schedules will be developed using faculty advice and the author's personal knowledge. Costs will include structural components, general conditions items, and any other changes that might be required as a result of the redesign. These will be determined using a detailed take-off of materials in typical bays and cost data from RS Means.

Breadth 2: Mechanical & Sustainability: Viability Study

Energy is becoming a crucial factor in the building industry since costs are rising due to its lack of availability. In fact, many firms and architects are looking for alternative energies to design the ultimate zero-energy building. One of those alternative energies is the sun. In addition, industry professionals are now familiar with the sustainability ranking system produced by the United States Green Building Council (USGBC) known as LEED (which stands for Leadership in Energy and Environmental Design). This system allocates a certain number of points to various technologies or design practices which are deemed to be sustainable. At certain point totals, the building can earn LEED ratings to indicate how sustainable it is.

However, what LEED doesn't consider is the cost of the green system and green energy. In fact, since technologies in those fields are just maturing sometimes going green is not the best option for the owner. For example, the study of photovoltaic glazing will be considered in this proposal aiming at increasing the building's energy performance. This was chosen since more than 60% of the J.B. Byrd Center is curtain wall glazing with different transparencies. Also, as the building is located in San Diego, it will see more than 146 sunny days and 117 partly cloudy days in which 30% are more sunny than cloudy. The figure below shows a 50% transparency photovoltaic glazing system.



Figure 10- Photovoltaic glazing system of 50% transparency from Atlantis Energy Systems

Furthermore, to deem this option as a sustainable and money saving solution a study of the product will be done on the following: production, transportation, installation, and maintenance, life cycle, payback period and demolition/recycling of the product under consideration. Payback period is the most important factor for the owner's decision. It determines how much a premium product costs to how much it saves in comparison to a standard product. This is achieved by expressing how long it will take for the savings due to the premium product to equal the additional cost of the product.

In addition, many factors will affect the payback period other than the photovoltaic system itself. If time permits, the additional costs accrued for structural, mechanical and schedule changes as well as monetary savings per year will be analyzed.

MAE Material Incorporation

Much of the calculation of the proposed redesign will draw upon material learned in MAE courses. Computer modeling techniques taught in AE 597A or Computer Modeling will be an integral tool in the completion of this redesign. Concepts such as insertion points, rigid diaphragm constraints, panel zone modeling, property modifiers, and modal analysis results determination were taught for ETABS and SAP 2000. These skills will be applied to ETABS and potentially SAP.

The design of the concrete moment frames and base isolators will rely heavily on material presented in AE 538 or Earthquake Design. The limitations and requirements for a special concrete moment frame and the procedures used to implement performance-based design will be of particular use. However, even though base isolation wasn't covered in depth, the design of such system will be done through faculty advice and the author's own research and knowledge.

Finally, to decide the feasibility of a photovoltaic glazing system, AE 542 or building enclosures will be used. The knowledge acquired in the MAE course will aid in the analysis and installment of such a glazing system. Also, the author will use a product developer that will later be determined through intensive research and faculty advice.

Method

The study will begin with a gravity system redesign of a cast-in-place concrete system in compliance with the ACI 318-08. This will incorporate the original superimposed dead load and live loads of the building. Typical bays in each wing at the 2nd, 7th, and Roof Levels will be designed by hand to minimize the increase in structural depth in comparison to the existing structure. These preliminary sizes will be input into ETABS Structural System, and a verification of gravity strength will be performed on all members. ETABS will be used to optimize the structure where possible.

After the initial preliminary design is accomplished, the new lateral loads will be determined using the Equivalent Lateral Force method for seismic loads and Main Wind Resisting System method for wind loads. The building is relocated to San Diego, CA. New seismic and wind loads will be calculated according to ASCE 7-05 to verify seismic loads are the controlling lateral case. The lateral loads will then be compared between the current location of building and the proposed location (USD campus).

Once the loads are determined the controlling load case will be established to design the lateral system. The later will defer from the existing system by the number of moment frames and their placement, shear wall lengths and thickness and finally reinforcement detailing. Since the building is an L-shaped building (torsional irregular), the layout will be established such that the moment frames are continuous throughout the wings in which the frames are located and there is sufficient length of frames in each wing to resist the applicable lateral forces.

Once the layout of the concrete moment frames has been optimized, a base isolation system will be chosen. In fact, an in depth calculation will be conducted to design the base isolators by specifying the right damping ratio, placement, connection to the superstructure and compressive strength. All design calculations will be performed for a representative frame by hand. ASCE 41-06 will dictate the requirements for the traditional moment frame, and the design of the base isolators. A finite element modeling program such as ETABS or SAP 2000 will be used to determine the building's response. This was chosen since these programs already have base isolators imbedded reducing any errors in attempting to model these elements.

Upon completion of the linear analysis, a comparison will be conducted between the two systems to define the main differences. The comparison should include deflections, inter-story drifts, period, forces in members, etc. Then, if time permits, another system will be done that optimizes the base isolation system to make it perform the same as the traditional cast-in-place system. Therefore, a true comparison between the two systems will be conducted to finally conclude which system is more efficient in cost, schedule and performance.

Finally, a sustainable/mechanical/energy optimization will be done to the façade glazing system. Information on the different photovoltaic systems that exist in California, as well as sunlight data applicable to the site and the building's assumed placement should be obtained. After all the information is obtained, a new system using the applicable standards will be designed to enhance the use of the curtain wall glazing façade.

Tasks and Tools

Depth: A Cast-in-Place Dual System vs. A Cast-in-Place Dual System with Base Isolators

Task 1: Design Cast-in-Place Gravity System

- Determine slab thickness based on loading in the original structural drawings
- Size beams/girders/columns in typical bays by hand calculations for required loading, serviceability concerns, and structural depth limitations according to ACI 318-08

Task 2: Choose Base Isolation System

- Recalculate seismic forces using the Equivalent Lateral Force method and wind loads using Main Wind Resisting System method according to ASCE 7-05. It should be verified that seismic controls assuming the building is based in San Diego, California
- Choose appropriate type of base isolators based on the forces and requirements needed
- Place the base isolators (different if assuming retro-fitting)

Task 3: Design Moment Frames and Shear Walls

- May be necessary to redesign bay sizes as there is a lot of open space which might not suit a seismic region such as San Diego, CA.
- Re-size beams and columns if needed according to bay sizes and re-design connections in order to resist the appropriate lateral forces
- Increase the number of moment connections since the current number may not be enough
- Create moment frame layout to minimize torsion, irregularities, and architectural impacts
- Re-design shear walls reinforcements appropriately as well as slab to wall connections
- Note: may need to re-size shear walls considering thickness, length and placement since the building is irregularly torsional

Task 4: Modeling Process and Verification of Work

- Model Building using ETABS to design remaining frames and optimize as required.
- Verify damage and deflection criteria are met as given by ASCE 7-05

Task 5: Design Base Isolators

- Become familiar with provisions for the design of structures incorporating base isolators, as given in ASCE 7-05 and select design method
- Calculate seismic loads as required for the selected design
- Design the base isolators (size, exact placement, detailing of the connection to the building etc.) as required for ASCE 41-06
- Model the new base isolators in ETABS (if possible) to verify the adequacy of the system chosen and design
- Verify damage and deflection criteria are met as given by ASCE 7-05

Task 6: Comparison of Systems

- Compare how the two systems reacted to the calculated loads from the Equivalent Lateral Force method. The comparison should include deflections, inter-story drifts, period, forces in members, etc.
- Re-size down or decrease the amount of reinforcement in beams/columns/walls and connections if necessary in the base isolated system to match the drifts in the non-base isolated system. This is done to see how much the difference will be affected at the micro-level implying cost and schedule. (Note this last step will be done only if time permits)

Breadth 1: Construction Management: Cost and Schedule Analysis*Task 1: Material Take off*

- Use typical bays to determine material quantities required such as concrete, steel reinforcement and base isolators

Task 2: Schedule Analysis

- Research typical productivity rates, likely via RS means in San Diego, California
- Research base isolation installment method and time in San Diego, California
- Produce schedule for structural activities for each system using a scheduling program such as Microsoft Project or Excel

Task 3: Cost Analysis

- Research typical cost units, likely via RS means in San Diego, California
- Research the cost of a base isolator unit in San Diego, California
- Produce cost estimate for each structural system and any additional architectural components required using Microsoft Excel

Breadth 2: Mechanical/Sustainability: Viability Study*Task 1: Research Photovoltaic Glazing System*

- Obtain information on the different photovoltaic systems that exist in California
- Choose a system type that best fit the building without altering much the current glazing

Task 2: Solar Photovoltaic Glazing System Design and Assessment

- Obtain sunlight data applicable to the site and the building's assumed placement
- Search online or contact vendor to determine cost/energy savings of a typical system
- Identify standards governing system design using faculty advice
- Design the system using the applicable standards
- Determine the increase or decrease of costs associated with structure/MEP/schedule
- Perform life cycle assessment meeting the requirements in Ecological Footprint Standards 2009 published by Global Footprint Network
- Determine payback period

Schedule

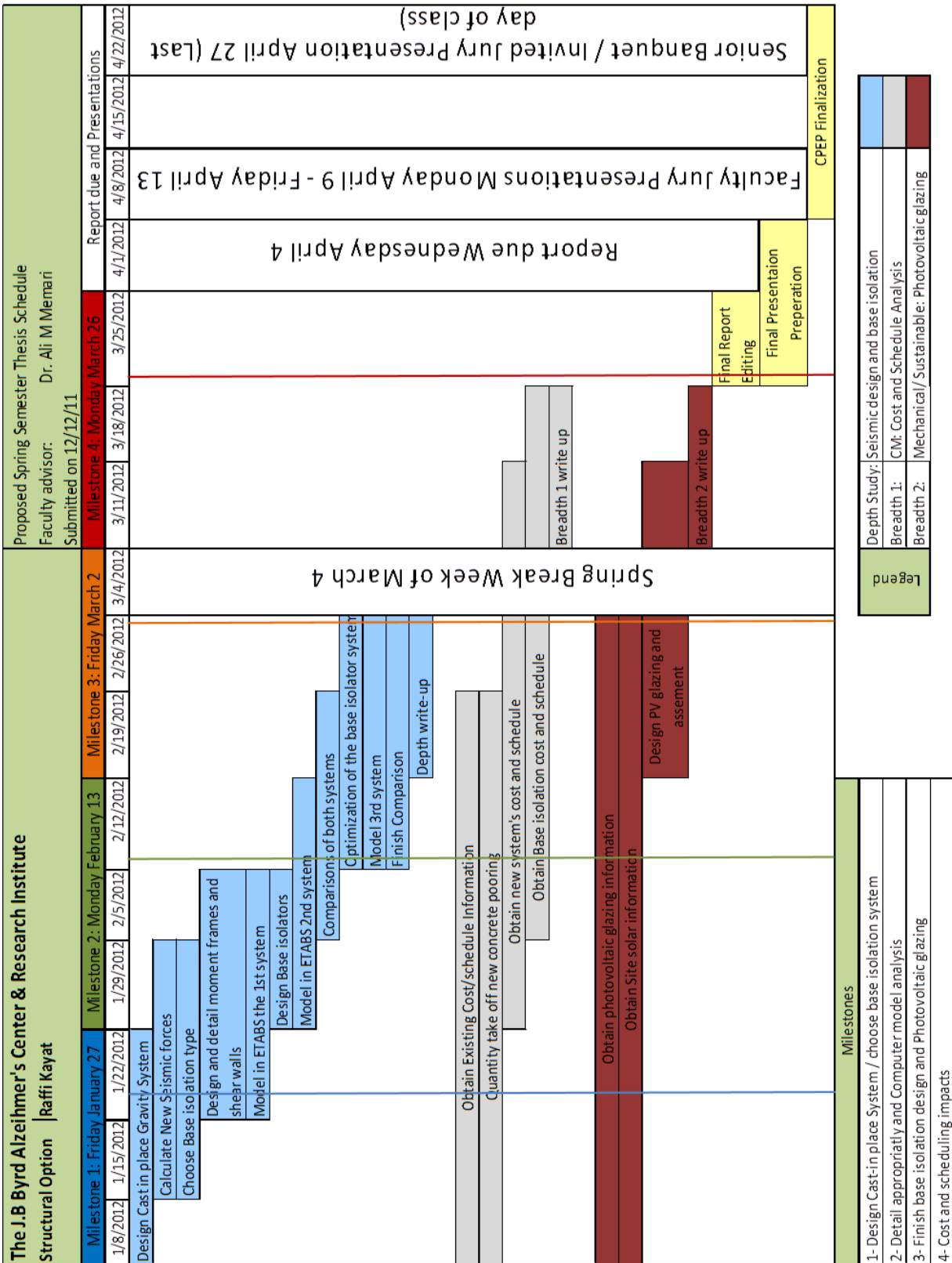

Figure 11 - Proposed Schedule using Microsoft Excel

Conclusion

The proposed redesign of the J.B. Byrd Alzheimer's Center & Research Institute focuses on building performance and efficiency while creating a viable solution for the building's structure in cast-in-place concrete. It is expected that changing construction method from primarily precast joists and beam soffits to cast-in-place will cause a change in cost and schedule. Also, the fact that the building is being relocated to San Diego, California, seismic forces will control the building design. Following the design of a cast-in-place gravity system, two lateral systems will be considered: A Cast-in-Place Dual System (Moment Frames and Shear Walls) and the same Cast-in-Place Dual System (Moment Frames and Shear Walls) with Base Isolators. An optimized cast-in-place system with base isolation of equal performance to the first system will be done if time permits as a third system. This later is done for comparison reasons to yield which system is better.

A construction management breadth focusing on creating a schedule and detailed estimate for the structural systems will facilitate comparison of the structural systems. Of particular interest are: which system (precast joists and soffit beams or cast-in-place concrete) is more efficient. Also of interest is which system (cast-in-place concrete or cast-in-place concrete with base isolators) is more efficient. In addition, the proposal will also focus on how much additional cost is accrued in moving the concrete frame from a non-seismic region to a high seismic region, how base isolators affect a building's response, how much cost results from designing for a base isolated system, and which system is more efficient.

Lastly, a sustainability viability study will be conducted for the addition of solar photovoltaic glazing to the curtain wall facade upon moving the building to California. This is possible because of the sunlight abundance and lack of winter season in San Diego, California. Since the technology is feasible in Tampa, Florida, if the result of the system is deemed to be practical it will give the owner a sustainable option now and in the future. This is of course assuming the costs and Sun-days in both Florida and California are relatively the same. To achieve a complete picture of sustainability, the system will be assessed based on cost, savings as a result of using the system, additional LEED points gained, a life cycle assessment, and the payback period of the system.