



Technical Report 2: Electrical Systems Criteria and Existing Conditions

Princeton Theological Seminary Library

Princeton, NJ

Stephanie Deckard

Lighting | Electrical

Faculty Advisor | Dr. Kevin Houser

10/12/2012

Executive Summary

This report identifies the electrical design criteria based on the building type, details the actual electrical design, evaluates the existing performance of the building based on this information and makes suggestions on how to improve the performance of the building. Numerical data being calculated includes normal, emergency power and optional back-up power loads. Other evaluation criterion includes equipment choices, voltage, services and rate schedule choices, building services and special/communication systems.

Based on the design criteria and priority assessment, the existing electrical distribution design fits the functions of the building really well. There are some improvement suggestions that could be implemented to save energy and/or increase control over the building systems and safety. Increasing integration by connecting the fire alarms with the telephone, intercom or CATV through data connections would increase the occupant awareness in case of an emergency, vastly increasing safety. Costs saving solutions include both energy saving techniques as well as suggestions on equipment changes. To decrease the energy usage of the building, demand reduction and demand shifting could be implemented. Combining equipment such as the smaller transformers providing service to the electrical rooms on each floor as well as combining the electrical rooms on each floor into one room versus many small rooms would allow for that floor area to be used for a different purpose.

Table of Contents

Executive Summary	2
Part 1 Electrical System Criteria and Scope of Work	4
I. Preliminary Electrical Load Calculation.....	4
II. Power Company and Preliminary Rate Schedule	4
III. Preliminary Building Utilization Voltage	5
IV. Emergency Power Requirements	5
V. Special Occupancy Requirements.....	7
VI. Special Equipment	7
VII. Priority Assessment	7
VIII. Optional Back-up Power.....	8
IX. Special/Communications Systems	9
X. Other Building Services	9
XI. Major Equipment	10
Part 2 Electrical System as Currently Designed.....	11
I. Actual Connected Building Load.....	11
II. Power Company and Rate Schedule	12
III. Building Utilization Voltage.....	13
IV. Emergency Power System Loads.....	14
V. Special Occupancy Requirements.....	14
VI. Special Equipment	15
VII. General Equipment	15
VIII. Optional Back-up Loads	16
IX. Special/Communications Systems	17
X. Other Building Services	17
XI. Electrical and Communications Systems Spaces.....	18
XII. Energy Cost Savings and Energy Reduction Techniques	18
XIII. Single Line Diagram	19
Part 3 Evaluation of Criteria vs. Current Design	20
I. Building Loads.....	20
II. Power Company Rate Schedule.....	20
III. Building Utilization Voltage.....	21
IV. Emergency Power System	21
V. General Equipment	21
VI. Optional Back-up Power and UPS Systems	22
VII. Cost Reduction Techniques	22
VIII. Systems Integration.....	22
IX. Energy Cost Savings and Energy Reduction Techniques	23

Part 1 | Electrical System Criteria and Scope of Work

The following section describes in detail the design criteria for this type of building and identifies potential building systems and electrical requirements.

I. Preliminary Electrical Load Calculation

Information taken from www.eia.gov was used to calculate the average electrical load of the building. Libraries are included in the category of office building which has a site electricity average of 198 billion kWh or 18.9 kWh/sqft. This value is broken down into the following categories:

Lighting = 8.32 kWh/sqft

Office Equipment = 4.54 kWh/sqft

Ventilation = 1.51 kWh/sqft

Cooling = 2.65 kWh/sqft

Space Heating = 0.57 kWh/sqft

Other = 1.51 kWh/sqft

These correspond to approximately:

Lighting ~ 2.5 W/sqft

Receptacle and other ~ 1 W/sqft

Mechanical ~ 4.1 W/sqft

Special Equipment ~ 6 W/sqft

II. Power Company and Preliminary Rate Schedule

PSE&G (Public Service Enterprise Group) is the power company that supplies power to the Princeton, NJ area. PSE&G serves almost three quarters of New Jersey's population and provides both electric and gas service. The Princeton Theological Seminary Library falls under the rate schedule category General Lighting and Power Service (GLP). The primary service voltage chosen is 2,400/4,160 (4kV) volts, three phase, four wire, WYE. This information was taken from the following website:

http://www.pseg.com/family/pseandg/tariffs/electric/pdf/electric_tariff.pdf

III. Preliminary Building Utilization Voltage

The Building Utilization voltage will be 480/277V with the voltages shown below serving each of the following loads:

Lighting = 277V

Receptacle = 120V

Mechanical = 480V 3P with small step down transformers where needed

Special Equipment

Elevators @ 480V

Audio Signal Processing, Amplification, and Reproduction Equipment @ 120V

Information Technology Equipment @ 120V

Solar Photovoltaic (PV) systems @ 120V

IV. Emergency Power Requirements

Considered as occupancy type Assembly A-3, the following are emergency power requirements based on the International Building Code. The estimated loads for the emergency power use an average of 1 footcandle in areas that require lighting during a power failure for safety and egress purposes. All other requirements mentioned in relation to this building are listed below. Emergency power will be provided through a diesel generator at 480/277V. A preliminary load calculation based on the criteria below can be broken down into the following categories:

Lighting = 0.12 W/sqft

Exit signs, egress

Mechanical = 0.7 W/sqft

Smoke control, horizontal sliding doors

Special Equipment = 2 W/sqft

Elevators, intercom, platform lifts

Total = 2.82 W/sqft

Emergency power shall be provided for voice communication systems with an approved emergency power source. (907.2.1.2)

Standby power shall be provided for smoke control systems with two sources of power. Primary power is fed from the normal building power and secondary power from an approved standby source. (909.11)

Emergency power shall be provided for exist signs from storage batteries, unit equipment or an on-site generator. (1011.5.3)

Emergency power shall be provided for means of egress illumination in the following areas (1006.3):

- Aisles and unenclosed egress stairways in rooms and spaces that require two or more means of egress

- Corridors, exit enclosures and exit passageways

- Exterior egress components at other than the level of exit discharge until exit discharge is accomplished

- Interior exit discharge elements

- Exterior landings for exit discharge doorways

Standby power shall be provided for elevators that are part of an accessible means of egress and shall be in accordance with the following (1007.4):

- Standby power shall be manually transferable to all elevators in each bank

- Where two or more elevators are controlled by a common operating system, all elevators shall automatically transfer to standby power within 60 seconds after failure of normal power where the standby power source is of sufficient capacity to operate all elevators at the same time.

- Where the standby power source is not of sufficient capacity to operate all elevators at the same time, all elevators shall transfer to standby power in sequence, return to the designated landing and disconnect from the standby power source. After all elevators have been returned to the designated level, at least one elevator shall remain operable from the standby power source.

- The elevator machine room ventilation or air conditioning shall be connected to the standby power source

Standby power shall be provided for platform lifts that are part of an accessible means of egress (1007.5)

Standby power shall be provided for horizontal sliding doors (1008.1.3.3)

- The doors shall be power operated and shall be capable of being operated manually in the event of a power failure

- The door assembly shall have an integrated standby power supply

- The door assembly power supply shall be electrically supervised

V. Special Occupancy Requirements

As listed in Chapter 5 of the National Electric Code Book 2011, the following special occupancy requirements apply to the Princeton Theological Seminary Library.

Section 518 | Assembly Occupancies

VI. Special Equipment

As listed in Chapter 6 of the National Electric Code Book 2011, the following special equipment could potentially be included in the Princeton Theological Seminary Library.

Section 620 | Elevators

Section 640 | Audio Signal Processing, Amplification, and Reproduction Equipment

Section 645 | Information Technology Equipment

Section 690 | Solar Photovoltaic (PV) systems

VII. Priority Assessment

A priority assessment was conducted to determine which of the following characteristics are of high, medium or low importance. This ranking was based on the building type and uses as well the assumed loads and long term building owner.

High

Long term ownership cost is very important because the Princeton Theological Seminary School will own and occupy the building. This library will most likely be used for a long time based on the information known about the library building that used to occupy this plot. The Speer Building that was erected in 1957 was only recently demolished in 2010 to build this addition.

Power quality is also very important because the building contains data and server rooms that would be heavily affected by unwanted harmonics.

Medium

Initial cost is of medium importance because any energy saving techniques would benefit the owner in the long run but being a school, they do not have an endless amount of money to spend.

Each space in the building has a very specific purpose so flexibility is not a large concern. It still much be considered though because as technology improves, new computers will be installed as well as new video conferencing equipment in the Assembly Room.

Reliability is important in this building because of the large number of computers being used.

Low

Redundancy is a low priority because it could not be utilized in the majority of the spaces due to the fact that there are many different types and sizes of spaces throughout the building.

VIII. Optional Back-up Power

The following loads should be on back-up power by either a generator, for long term power that will have an initial power outage or a UPS for short term power with no blackout time.

Generator

Lighting in Mechanical and Electrical Rooms

HVAC in Mechanical and Electrical Rooms

Total = 1 W/sqft

UPS

Server Room

Computer Rooms

Total = 2 W/sqft

IX. Special/Communications Systems

The following special and communications systems are a preliminary selection of what could be implemented into the Princeton Theological Seminary Library. Additional information is provided from the International Building Code on information regarding the implementation of fire alarms.

Telephone/data

CATV

Fire alarm

A manual fire alarm system shall be installed in Group A occupancies having an occupant load of 300 or more. Manual fire alarm boxes are not required where the building is equipped throughout with an automatic sprinkler system and the alarm notification appliances will activate upon sprinkler water flow. (907.2.1)

Emergency voice/alarm communications systems shall be provided with an approved emergency power source. (907.2.1.2)

Intercom

Access Control – card access after hours

Security – video surveillance

X. Other Building Services

The following building services are a preliminary selection of what could be implemented into the Princeton Theological Seminary Library.

Telephone

Data

CATV

XI. Major Equipment

Typical major equipment used in this type of occupancy includes electrical equipment, large data center equipment and mechanical equipment. More specifically, rooms dedicated to transformers, switchgear, distribution panels as well as cooling towers and any major data equipment.

Part 2 | Electrical System as Currently Designed

This section provides information on the actual building loads, equipment and building systems.

I. Actual Connected Building Load

The actual connected building load is broken down into categories of lighting, receptacle, mechanical, special equipment and the total load as listed below.

Existing Loads				
	Lighting	Receptacle	Mechanical	Special Equipment
Substations A & E		***NO INFORMATION AVAILABLE		
Substations C & D		***NO INFORMATION AVAILABLE		
Erdman Hall Switchboard		***NO INFORMATION AVAILABLE		
PP-L			347.358	
PP-4	0.15	0.36	319.671	
EDP-ES				
ELP-ES-1	10.15			
EAP-ES-1		1.75	13.75	2.4
ELP-ES-3	6.54			
EAP-ES-3		1.5	1.2	
EDP-OS				
EAP-OS-L		29.67		
EPP-OS-L				
HWP-B1		17.451		
HWP-B2		17.451		
PH-1		***NO INFORMATION AVAILABLE		
CRU-1-1 (AH)		87.255		
CRU-1-1 (CU)		12.1326		
EF-B-2		1.3296		
HEAT TRACE IN COOLING TOWER		***NO INFORMATION AVAILABLE		
EPP-OS-4				
EF-R-1		11.634		
EF-R-2		11.634		
FCU-4-1		2.8254		
FZP-N1		1.3296		
FZP-E1		1.3296		
FZP-E2		0.9141		
FZP-W1		0.9141		
FZP-W2		1.3296		
AHU-N2		17.451		
CU-N2A		3.9888		
CU-N2B		3.9888		
SPRINKLER AIR COMPRESSOR		2.493		
EAP-OS-4		11.91		

EAP-IT				88.1
MDP-LUCE				
EXISTING LOADS		***NO INFORMATION AVAILABLE		
RP-LA		21.24		
RP-1B		10.82		
RP-2A		33.94		0.72
RP-3A		14.28		
EMR0021			54.015	
DP-L				
LP-L	23.79			
LP-1	26.48			
LP-2	13.13			
LP-3	16.26			
LP-4	6.12			
AP-L-1 (& AP-L-2)		38.88	4.63	3.38
AP-1-1 (& AP-1-2)	1.61	92.18	15.91	5.1
AP-2-1 (& AP-2-2)	1.32	44.8	7.01	3.1
AP-3-1 (& AP-3-2)	2.54	70.9	4.97	4.7
AP-IT				85.36
LP-SITE	8.12			
DP-PV		***NO INFORMATION AVAILABLE		
CH-1			283	
CH-2			283	
FIRE PUMPS				
JOCKEY PUMP			3.9888	
FIRE PUMP			63.987	
TOTALS IN CATEGORIES	116.21	567.68	1402.49	192.86
TOTAL (KVA)	2279.24			

II. Power Company and Rate Schedule

PSE&G is the power company for the Princeton Theological Seminary Library. The primary service voltage chosen is 13,200/7,620V, 3P, 4W. Information about the rate schedule was requested from the building owner.

III. Building Utilization Voltage

The electrical service provided to the building at 13,200/7,620V is fed into the main service switchgear, owned by the building owner, that branches out to two transformers. Transformer XFMR T-SG-L-3 steps down the voltage to 4,160/2,400V and serves the existing substations that provide power to the Luce Building. Transformer XFMR T-SG-L-2 steps down the voltage to 480/277V and serves Switchboard SG-L-2. This switchboard branches off to individual loads, distribution panels, switchboards and power panels that supply service to both existing and new loads.

Lighting = 120V and 277V

Receptacle = 120V

Mechanical:

AHUs @ 480V

VAVs @ 277V

Chillers @ 480V

Unit Heaters @ 120V

Exhaust Fans @ 480V and 120V

Fan Coil Units @ 480V and 120V

Freezer Protection Pumps @ 480V

Glycol Fill Tank @ 120V

Chilled Water and Heat Pumps @ 480V

Return Fan @ 480V

Duplex Septic Pump @ 208V

Transfer Fans @ 120V

Special Equipment

Elevators @ 480V

Audio Signal Processing, Amplification, and Reproduction Equipment @ 120V

Information Technology Equipment @ 120V

Solar Photovoltaic (PV) systems @ 120V

IV. Emergency Power System Loads

The emergency power is supplied by a generator at 400KW/500KVA, 3P, 4W, 60HZ, 480/277V. The generator is an outdoor, diesel driven unit in a sound attenuated nonwalk-in enclosure. Power from this generator is supplied to a distribution panel that has branches for the existing fire pumps and distribution panel in the Luce Building, an emergency distribution panel, an optional backup distribution panel and Panel EAP-IT that provides back-up power to the server room in the Luce Building.

Emergency Power Loads				
	Lighting	Receptacle	Mechanical	Special Equipment
FIRE PUMPS				
JOCKEY PUMP			3.9888	
FIRE PUMP			63.987	
EDP-LUCE				
EM		***NO INFORMATION AVAILABLE		
EM2		***NO INFORMATION AVAILABLE		
EXISTING AIR COMPRESSOR		***NO INFORMATION AVAILABLE		
EF-6		***NO INFORMATION AVAILABLE		
DDC		***NO INFORMATION AVAILABLE		
EXISTING ELEVATOR			66.48	
CP-7		***NO INFORMATION AVAILABLE		
EDP-ES				
ELP-ES-1	10.15			
EAP-ES-1		1.75	13.75	2.4
ELP-ES-3	6.54			
EAP-ES-3		1.5	1.2	
TOTALS IN CATEGORIES	16.69	3.25	149.41	2.40
TOTAL (KVA)	171.75			

V. Special Occupancy Requirements

There were no special occupancy requirements in the building drawings or specifications.

VI. Special Equipment

Information on the special equipment was found on the building drawings in the floor plans and appliance schedules.

Section 620 | Elevators

Section 640 | Audio Signal Processing, Amplification, and Reproduction Equipment

Intercom, Cameras

Section 645 | Information Technology Equipment

Equipment Racks in the Server Room, Computers

Section 690 | Solar Photovoltaic (PV) systems

VII. General Equipment

The general equipment located in the drawings and specifications is documented here in detail, to get an idea of the systems used in the design of the Princeton Theological Seminary Library. The main service transformer, rated at 15KV, 600A, is located in the basement of the new addition and is owned by PSE&G. The main service from this transformer is provided through a 600A, 13,700/7,620V, 3P, 4W, single ended, indoor switchgear. There are two transformers that branch from the main service switchgear. T-SG-L-3 is rated at 20,000KVA, 3P, 60HZ, 4,160/2,400V and XFMR T-SG-L-2 is rated at 1,500/1,725KVA, 3P, 60HZ, 480/277V. Both are dry-type, ventilated, NEMA 250, type 2 transformers. The panelboards for the building are both MCB and MLO with copper equipment and isolated ground buses. The bus rating is dependent on the circuit breaker size as specified below:

Circuit breaker frame sizes <125A = bolt-in

Circuit breaker frame sizes >125A = bolt-in, plug-in where individual positive-locking device requires mechanical release for removal

The conductors are all copper wire protected by both metallic and nonmetallic conduit. The types used follow typical practices. This includes EMT for branch circuits, LFMC and LFNC for connections to motors, FMC for office equipment. For special applications such as conduit run through ductbanks and concrete, rigid nonmetallic conduit was used. Feeders are copper, #10 AWG wires with RNC conduit. The receptacles used are industrial grade, decorator series with the following wall plate materials chosen by the architect:

Plate-Securing Screws: Metal

Material for Finished Spaces: Smooth, nylon.
 Material for Unfinished Spaces: Smooth, nylon.
 Material for Damp Locations: aluminum

Variable frequency motor speed controllers (VFD) are used for speed control of three-phase, square-cage induction motors. There is not a UPS used in this project.

VIII. Optional Back-up Loads

The optional back-up loads are combined with the emergency power under one generator. The main distribution panel, EDP-OS, serving the option loads is rated at 400A, 480/277V and serves individual loads and two power panels. Server room panel loads for the Luce Building are also included in the optional power system. The power branches out from the main emergency distribution panel with a transformer that changes the voltage to 208/120V.

Optional Back-up Power Loads				
	Lighting	Receptacle	Mechanical	Special Equipment
EDP-OS				
EAP-OS-L		29.67		
EPP-OS-L				
HWP-B1		17.451		
HWP-B2		17.451		
PH-1		***NO INFORMATION AVAILABLE		
CRU-1-1 (AH)		87.255		
CRU-1-1 (CU)		12.1326		
EF-B-2		1.3296		
HEAT TRACE IN COOLING TOWER		***NO INFORMATION AVAILABLE		
EPP-OS-4				
EF-R-1		11.634		
EF-R-2		11.634		
FCU-4-1		2.8254		
FZP-N1		1.3296		
FZP-E1		1.3296		
FZP-E2		0.9141		
FZP-W1		0.9141		
FZP-W2		1.3296		
AHU-N2		17.451		
CU-N2A		3.9888		
CU-N2B		3.9888		
SPRINKLER AIR COMPRESSOR		2.493		
EAP-OS-4		11.91		
EAP-IT				88.1
TOTALS IN CATEGORIES	0.00	237.03	0.00	88.10
TOTAL (KVA)	325.13			

IX. Special/Communications Systems

The following special/communications systems are implemented into the design of the Princeton Theological Seminary library. System integration examples used in the building are also identified below.

Telephone/data

Occupancy sensors and daylight sensors that control dimming of fixtures and shade operation are connected to a GRAFIK Eye that uses a data connection.

Fire Alarm

CATV

Intercom

Security – Video Surveillance

X. Other Building Services

The following building services are implemented into the Princeton Theological Seminary Library.

Telephone

Data

CATV

XI. Electrical and Communications Systems Spaces

Dedicated electrical and communications systems spaces account for 2% of the total square footage of the building. Included below is a list of these dedicated spaces along with their individual square footage.

Dedicated Electrical Rooms

Luce Building - Main Emergency Electrical Room 0123 = 266sqft

Luce Building - Electrical Room 0105 = 113sqft

New Addition - Electrical Room 0071 = 90sqft

New Addition - Main Electrical Room 0047 = 917sqft

Luce Building - Electrical Room 1105 = 113sqft

New Addition - Electrical Room 1071 = 90sqft

New Addition - Electrical Room 2071 = 90sqft

New Addition - Electrical Room 3071 = 90sqft

Dedicated Data Rooms

New Addition - Data Room 0072 = 96sqft

New Addition - Server Room 1110 = 581sqft

New Addition - Data Room 1072 = 96sqft

New Addition - Data Room 2072 = 96sqft

New Addition - Data Room 3072 = 96sqft

XII. Energy Cost Savings and Energy Reduction Techniques

The energy savings technique used in the design of the Princeton Theological Seminary Library utilizes PV arrays located on the roof of the new addition. The layout of these panels is shown in the figure below. The implementation of this energy saving technique also contributes to the LEED Silver certification of the building.

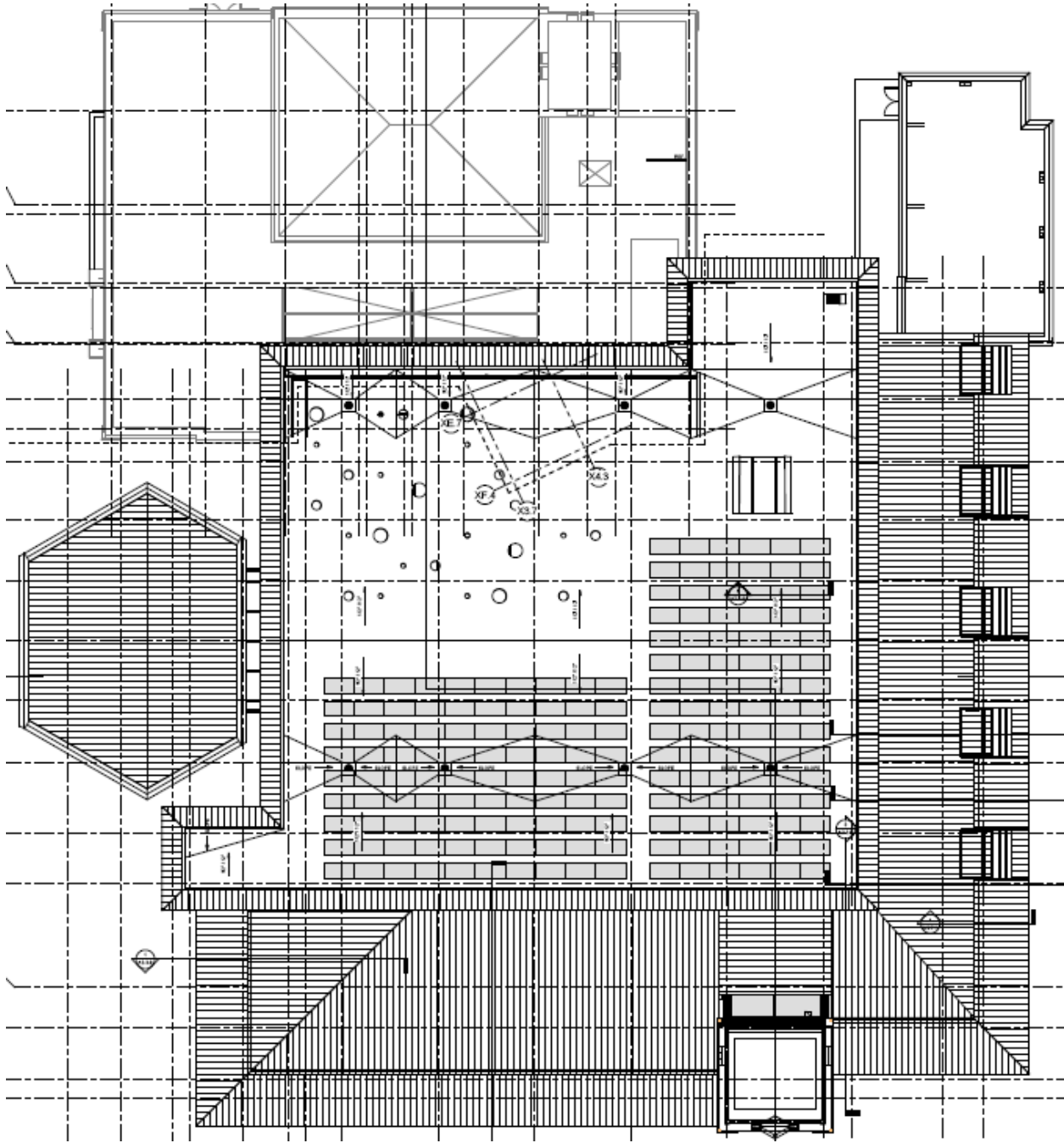

Figure 1 | PV Array Roof Layout

XIII. Single Line Diagram

The complete normal, emergency and optional back-up power single line diagrams are shown below on the following pages.

Copyright © 2008 by EWM/COLLE

DRAWING NOTES:

- ELECTRICAL CONTRACTOR SHALL FIELD VERIFY ALL EXISTING FEEDER CONDUIT SIZES PRIOR TO COMMENCEMENT OF WORK. IF THERE ARE ANY DISCREPANCIES BETWEEN THE DRAWINGS AND ACTUAL FIELD CONDITIONS NOTIFY ENGINEER TO OBTAIN PROPER COURSE OF ACTION BEFORE PROCEEDING WITH INSTALLATION.
- PROVIDE CONTROL WIRING IN CONDUIT TO FIRE ALARM CONTROL RELAY IN ELEVATOR MACHINE ROOM.
- ACTUAL FUSE SIZE SHALL BE CONFIRMED UPON REVIEW OF ELEVATOR SHOP DRAWINGS.
- PROVIDE TWO HOUR UL CLASSIFIED FIRE RESISTIVE POWER TYPE MI CABLE OR W/ALK RHWY F4-100. INSTALL PER MANUFACTURER'S INSTRUCTIONS FOR A LISTED TWO HOUR FIRE RATED SYSTEM PER NEC AND IC.
- PROVIDE BREAKER WITH PADLOCK IN LOCKABLE ENCLOSURE WITH 300A LOCK BREAKER IN THE CLOSED POSITION, 300A TO READ "FIRE PUMP DISCONNECT".
- PROVIDED UNDER SITE UTILITIES PACKAGE.
- UTILITY METER, CTS, AND PT'S FURNISHED BY PSE&G. INSTALLED BY ELECTRICAL CONTRACTOR PER PSE&G SPECIFICATIONS. ELECTRICAL CONTRACTOR IS REQUIRED TO SCHEDULE ON-SITE MEETING WITH PSE&G REPRESENTATIVE, AND SCHEDULE APPROPRIATE TO PICK UP FURNISHED EQUIPMENT PRIOR TO COMMENCEMENT OF WORK.
- PROVIDE SPILT BUS COMPARTMENT BY FRAME ISOLATE. PROVIDE IN-LINE NORMALLY CLOSED CONTACTOR FOR CONTROLLING HALF OF SPILT BUS PANEL(S) AS INDICATED IN PANEL BOARD SCHEDULES IN SPECIFICATION SECTION 20000. PROVIDE CONTACTOR RATING AS REQUIRED, AND ASSOCIATED COIL RATED FOR 24V TO BE CONTROLLED BY BUILDING AUTOMATION SYSTEM. ALL 24V WIRING BY DIVISION 25. COORDINATE WITH OWNER AND DIVISION 25.

GENERAL NOTES

- FOR SYMBOLS AND ABBREVIATIONS REFER TO DRAWINGS EQ-1.
- FOR ACTUAL PHYSICAL LOCATION OF ELECTRICAL EQUIPMENT RESERVING WORK UNDER THIS PROJECT REFER TO PLANS AND DETAILS AS LISTED IN THE DRAWING INDEX.
- UNLESS OTHERWISE NOTED, ALL ELECTRICAL EQUIPMENT AND WIRING SHOWN IN A DASH, SOLID LINE ARE NEW WORK UNLESS OTHERWISE NOTED.
- JUNCTION AND PULL BOXES ARE NOT NECESSARILY SHOWN ON THE DRAWING AND SHALL BE PROVIDED WHERE NECESSARY AND BE IN ACCORDANCE WITH THE NATIONAL ELECTRICAL CODE AND INSTALLED WHERE REQUIRED.
- ALL SHORT CIRCUIT INTERRUPTING RATINGS SHOWN, WHETHER AIC OR AWA, ARE CALCULATED BASED ON SYMMETRICAL VALUES AT THE LINE TERMINALS OF THE EQUIPMENT. THE WITHSTAND SHORT CIRCUIT CURRENT RATINGS OF PROTECTIVE DEVICES, TRANSFER SWITCHES, AND BUS BRACINGS SHALL BE EQUAL TO OR GREATER THAN THE VALUES INDICATED.
- UNLESS OTHERWISE NOTED, ALL CIRCUIT BREAKERS, MOTOR CIRCUIT PROTECTORS (MCP) AND SWITCHES ARE THREE (3) POLE.
- UNLESS OTHERWISE NOTED, ALL ELECTRICAL EQUIPMENT AND WIRING SHOWN IN A LIGHT, SOLID LINE ARE EXISTING TO REMAIN.
- UNLESS OTHERWISE NOTED, ALL ELECTRICAL EQUIPMENT AND WIRING SHOWN IN A LIGHT, DASHED LINE ARE FUTURE WORK.

KEY PLAN

PROJECT MANAGER
PATRICK BRUNNER
Engineering Leader
ROBERT GHISU
Project Designer
MICHAEL GLINDER

REVISIONS

NO.	BY	DESCRIPTION	DATE

PRINCETON THEOLOGICAL SEMINARY LIBRARY PRINCETON, NEW JERSEY CONSTRUCTION DOCUMENTS

DRAWN BY: **MG** DATE: **SEPTEMBER 21, 2010**

PROJECT NO: **20080548** SCALE: **NONE**

DRAWING NAME: **SINGLE LINE DIAGRAM - SERVICE SWITCHGEAR SG-1-1 AND SUBSTATIONS SG-1-2 AND SG-1-3 - NEW WORK**

FLOOR/SECTION: **PHASE** DRAWING NO.:

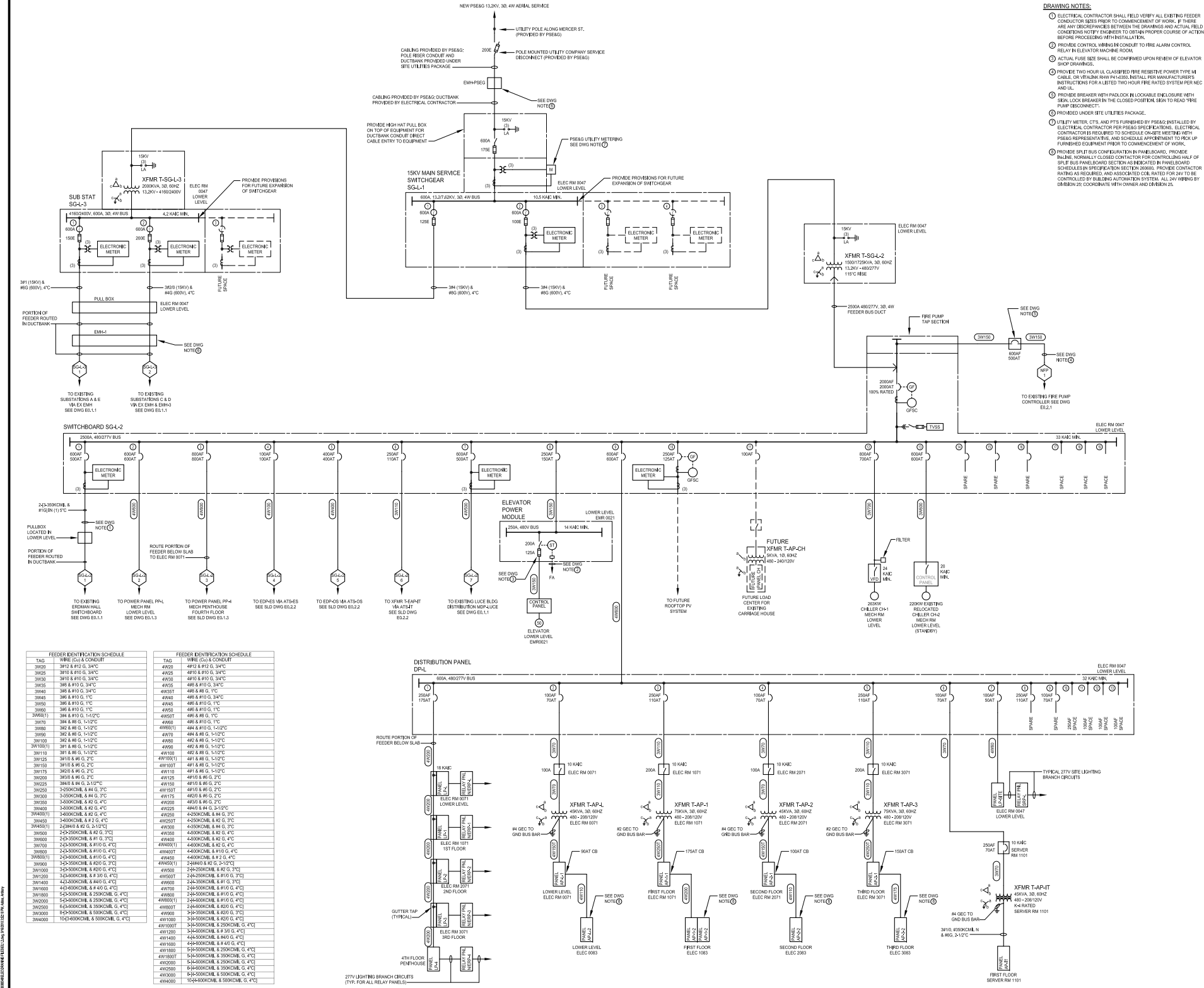

FEEDER IDENTIFICATION SCHEDULE	FEEDER IDENTIFICATION SCHEDULE
TAG	WIRE (G) & CONDUIT
3W29	3#12 & #12 G, 3/4"
3W30	3#10 & #10 G, 3/4"
3W31	3#10 & #10 G, 3/4"
3W32	3#8 & #10 G, 3/4"
3W33	3#8 & #10 G, 3/4"
3W34	3#8 & #10 G, 3/4"
3W35	3#8 & #10 G, 3/4"
3W36	3#8 & #10 G, 3/4"
3W37	3#8 & #10 G, 3/4"
3W38	3#8 & #10 G, 3/4"
3W39	3#8 & #10 G, 3/4"
3W40	3#8 & #10 G, 3/4"
3W41	3#8 & #10 G, 3/4"
3W42	3#8 & #10 G, 3/4"
3W43	3#8 & #10 G, 3/4"
3W44	3#8 & #10 G, 3/4"
3W45	3#8 & #10 G, 3/4"
3W46	3#8 & #10 G, 3/4"
3W47	3#8 & #10 G, 3/4"
3W48	3#8 & #10 G, 3/4"
3W49	3#8 & #10 G, 3/4"
3W50	3#8 & #10 G, 3/4"
3W51	3#8 & #10 G, 3/4"
3W52	3#8 & #10 G, 3/4"
3W53	3#8 & #10 G, 3/4"
3W54	3#8 & #10 G, 3/4"
3W55	3#8 & #10 G, 3/4"
3W56	3#8 & #10 G, 3/4"
3W57	3#8 & #10 G, 3/4"
3W58	3#8 & #10 G, 3/4"
3W59	3#8 & #10 G, 3/4"
3W60	3#8 & #10 G, 3/4"
3W61	3#8 & #10 G, 3/4"
3W62	3#8 & #10 G, 3/4"
3W63	3#8 & #10 G, 3/4"
3W64	3#8 & #10 G, 3/4"
3W65	3#8 & #10 G, 3/4"
3W66	3#8 & #10 G, 3/4"
3W67	3#8 & #10 G, 3/4"
3W68	3#8 & #10 G, 3/4"
3W69	3#8 & #10 G, 3/4"
3W70	3#8 & #10 G, 3/4"
3W71	3#8 & #10 G, 3/4"
3W72	3#8 & #10 G, 3/4"
3W73	3#8 & #10 G, 3/4"
3W74	3#8 & #10 G, 3/4"
3W75	3#8 & #10 G, 3/4"
3W76	3#8 & #10 G, 3/4"
3W77	3#8 & #10 G, 3/4"
3W78	3#8 & #10 G, 3/4"
3W79	3#8 & #10 G, 3/4"
3W80	3#8 & #10 G, 3/4"
3W81	3#8 & #10 G, 3/4"
3W82	3#8 & #10 G, 3/4"
3W83	3#8 & #10 G, 3/4"
3W84	3#8 & #10 G, 3/4"
3W85	3#8 & #10 G, 3/4"
3W86	3#8 & #10 G, 3/4"
3W87	3#8 & #10 G, 3/4"
3W88	3#8 & #10 G, 3/4"
3W89	3#8 & #10 G, 3/4"
3W90	3#8 & #10 G, 3/4"
3W91	3#8 & #10 G, 3/4"
3W92	3#8 & #10 G, 3/4"
3W93	3#8 & #10 G, 3/4"
3W94	3#8 & #10 G, 3/4"
3W95	3#8 & #10 G, 3/4"
3W96	3#8 & #10 G, 3/4"
3W97	3#8 & #10 G, 3/4"
3W98	3#8 & #10 G, 3/4"
3W99	3#8 & #10 G, 3/4"
3W00	3#8 & #10 G, 3/4"
3W01	3#8 & #10 G, 3/4"
3W02	3#8 & #10 G, 3/4"
3W03	3#8 & #10 G, 3/4"
3W04	3#8 & #10 G, 3/4"
3W05	3#8 & #10 G, 3/4"
3W06	3#8 & #10 G, 3/4"
3W07	3#8 & #10 G, 3/4"
3W08	3#8 & #10 G, 3/4"
3W09	3#8 & #10 G, 3/4"
3W10	3#8 & #10 G, 3/4"
3W11	3#8 & #10 G, 3/4"
3W12	3#8 & #10 G, 3/4"
3W13	3#8 & #10 G, 3/4"
3W14	3#8 & #10 G, 3/4"
3W15	3#8 & #10 G, 3/4"
3W16	3#8 & #10 G, 3/4"
3W17	3#8 & #10 G, 3/4"
3W18	3#8 & #10 G, 3/4"
3W19	3#8 & #10 G, 3/4"
3W20	3#8 & #10 G, 3/4"
3W21	3#8 & #10 G, 3/4"
3W22	3#8 & #10 G, 3/4"
3W23	3#8 & #10 G, 3/4"
3W24	3#8 & #10 G, 3/4"
3W25	3#8 & #10 G, 3/4"
3W26	3#8 & #10 G, 3/4"
3W27	3#8 & #10 G, 3/4"
3W28	3#8 & #10 G, 3/4"
3W29	3#8 & #10 G, 3/4"
3W30	3#8 & #10 G, 3/4"
3W31	3#8 & #10 G, 3/4"
3W32	3#8 & #10 G, 3/4"
3W33	3#8 & #10 G, 3/4"
3W34	3#8 & #10 G, 3/4"
3W35	3#8 & #10 G, 3/4"
3W36	3#8 & #10 G, 3/4"
3W37	3#8 & #10 G, 3/4"
3W38	3#8 & #10 G, 3/4"
3W39	3#8 & #10 G, 3/4"
3W40	3#8 & #10 G, 3/4"
3W41	3#8 & #10 G, 3/4"
3W42	3#8 & #10 G, 3/4"
3W43	3#8 & #10 G, 3/4"
3W44	3#8 & #10 G, 3/4"
3W45	3#8 & #10 G, 3/4"
3W46	3#8 & #10 G, 3/4"
3W47	3#8 & #10 G, 3/4"
3W48	3#8 & #10 G, 3/4"
3W49	3#8 & #10 G, 3/4"
3W50	3#8 & #10 G, 3/4"
3W51	3#8 & #10 G, 3/4"
3W52	3#8 & #10 G, 3/4"
3W53	3#8 & #10 G, 3/4"
3W54	3#8 & #10 G, 3/4"
3W55	3#8 & #10 G, 3/4"
3W56	3#8 & #10 G, 3/4"
3W57	3#8 & #10 G, 3/4"
3W58	3#8 & #10 G, 3/4"
3W59	3#8 & #10 G, 3/4"
3W60	3#8 & #10 G, 3/4"
3W61	3#8 & #10 G, 3/4"
3W62	3#8 & #10 G, 3/4"
3W63	3#8 & #10 G, 3/4"
3W64	3#8 & #10 G, 3/4"
3W65	3#8 & #10 G, 3/4"
3W66	3#8 & #10 G, 3/4"
3W67	3#8 & #10 G, 3/4"
3W68	3#8 & #10 G, 3/4"
3W69	3#8 & #10 G, 3/4"
3W70	3#8 & #10 G, 3/4"
3W71	3#8 & #10 G, 3/4"
3W72	3#8 & #10 G, 3/4"
3W73	3#8 & #10 G, 3/4"
3W74	3#8 & #10 G, 3/4"
3W75	3#8 & #10 G, 3/4"
3W76	3#8 & #10 G, 3/4"
3W77	3#8 & #10 G, 3/4"
3W78	3#8 & #10 G, 3/4"
3W79	3#8 & #10 G, 3/4"
3W80	3#8 & #10 G, 3/4"
3W81	3#8 & #10 G, 3/4"
3W82	3#8 & #10 G, 3/4"
3W83	3#8 & #10 G, 3/4"
3W84	3#8 & #10 G, 3/4"
3W85	3#8 & #10 G, 3/4"
3W86	3#8 & #10 G, 3/4"
3W87	3#8 & #10 G, 3/4"
3W88	3#8 & #10 G, 3/4"
3W89	3#8 & #10 G, 3/4"
3W90	3#8 & #10 G, 3/4"
3W91	3#8 & #10 G, 3/4"
3W92	3#8 & #10 G, 3/4"
3W93	3#8 & #10 G, 3/4"
3W94	3#8 & #10 G, 3/4"
3W95	3#8 & #10 G, 3/4"
3W96	3#8 & #10 G, 3/4"
3W97	3#8 & #10 G, 3/4"
3W98	3#8 & #10 G, 3/4"
3W99	3#8 & #10 G, 3/4"
3W00	3#8 & #10 G, 3/4"

SEE ELEVATOR SHOP DRAWINGS FOR ELEVATOR POWER MODULES AND WIRING.

DRAWING NOTES:

- REROUTE EXISTING GENERATOR START SIGNAL CONTROL WIRING TO EXISTING TEMPORARY GENERATOR CONTROL PANEL DURING CONSTRUCTION. UPON INSTALLATION OF NEW OUTDOOR GENERATOR, REROUTE EXISTING FIRE PUMP CONTROLLER GENERATOR START SIGNAL CONTROL WIRING TO NEW GENERATOR CONTROL PANEL, AS REQUIRED TO RESTORE ORIGINAL OPERATION.
- PROVIDE FIRE PUMP START SIGNAL FROM EXISTING FIRE PUMP CONTROLLER TO BUILDING AUTOMATION SYSTEM (BAS) AS REQUIRED TO INHIBIT EMERGENCY MECHANICAL LOADS (SHEDDERS) THROUGH STARTING OF FIRE PUMP. START OF FIRE PUMP SHALL BE DELAYED TO COORDINATE WITH THE SHUT DOWN OF MECHANICAL UNITS WHILE STILL COMPLYING WITH CODE. COORDINATE ALL INSTALLATION REQUIREMENTS WITH COMMISSION 03.20 AND 28.

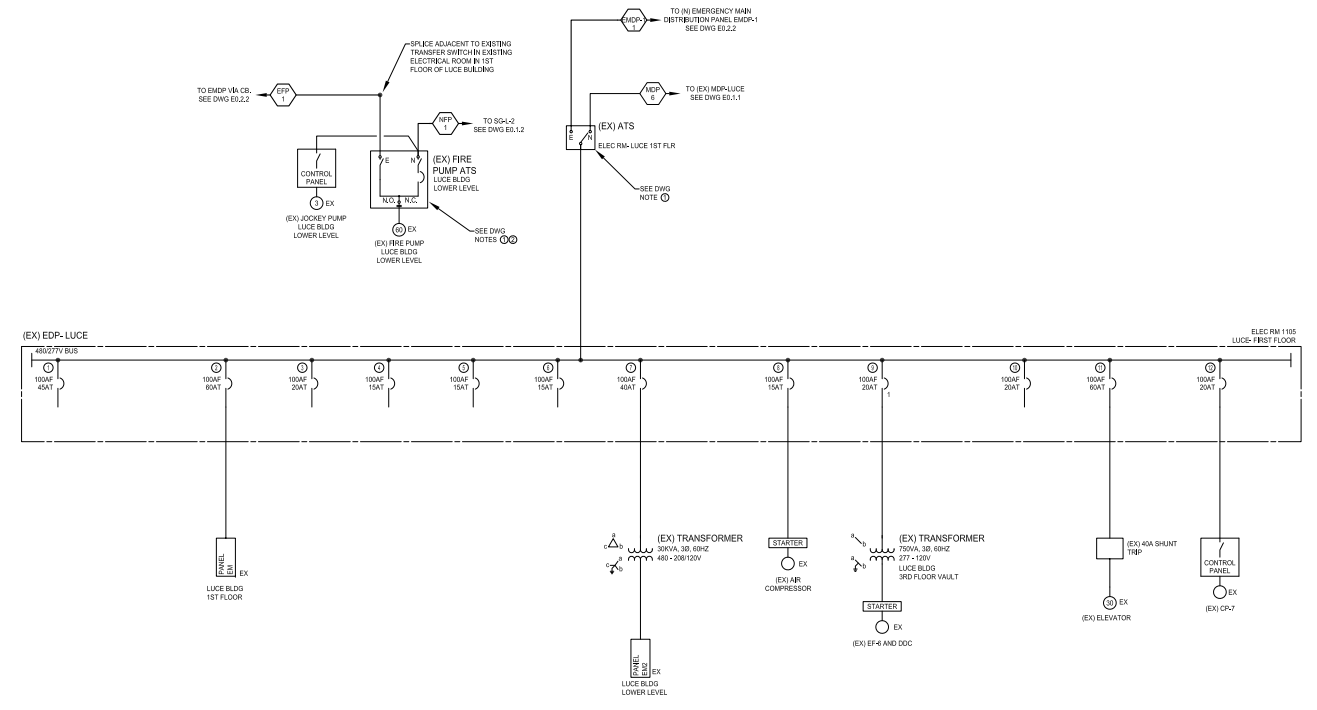

GENERAL NOTES

- FOR SYMBOLS AND ABBREVIATIONS REFER TO DRAWING EQ-1.
- FOR ACTUAL PHYSICAL LOCATION OF ELECTRICAL EQUIPMENT RESERVING WORK UNDER THIS PROJECT REFER TO PLANS AND DETAILS AS LISTED IN THE DRAWING INDEX.
- UNLESS OTHERWISE NOTED, ALL ELECTRICAL EQUIPMENT AND WIRING SHOWN IN A DARK, SOLID LINE ARE NEW WORK UNDER THIS PROJECT.
- JUNCTION AND PULL BOXES ARE NOT NECESSARILY SHOWN ON THIS DRAWING AND SHALL BE PROVIDED WHERE NECESSARY AND SIZED IN ACCORDANCE WITH THE NATIONAL ELECTRICAL CODE AND INSTALLED WHERE REQUIRED.
- ALL SHORT CIRCUIT INTERRUPTING RATINGS SHOWN, WHETHER IAC OR IWA E, ARE CALCULATED RMS SYMMETRICAL VALUES AT THE LINE TERMINALS OF THE EQUIPMENT. THE WITHSTAND SHORT CIRCUIT CURRENT RATINGS OF PROTECTIVE DEVICES, TRANSFER SWITCHES AND BUS BRACINGS SHALL BE EQUAL TO OR GREATER THAN THE VALUES NOTED.
- UNLESS OTHERWISE NOTED, ALL CIRCUIT BREAKERS, MOTOR CIRCUIT PROTECTORS (MCP) AND/OR SWITCHES ARE THREE (3) POLE.
- UNLESS OTHERWISE NOTED, ALL ELECTRICAL EQUIPMENT AND WIRING SHOWN IN A LIGHT, SOLID LINE IS EXISTING TO REMAIN.

KEY PLAN



PROJECT MANAGER
 PATRICK BRUNNER
 Engineering Leader
 ROBERT GHISU
 Project Designer
 MICHAEL GABLER

REVISIONS

NO.	BY	DESCRIPTION	DATE

PRINCETON THEOLOGICAL SEMINARY LIBRARY PRINCETON, NEW JERSEY CONSTRUCTION DOCUMENTS

DRAWN BY: MG DATE: SEPTEMBER 21, 2010
 PROJECT NO.: 20080548 SCALE: NONE
 DRAWING NAME: SINGLE LINE DIAGRAM - EMERGENCY - LUCE
 EXISTING CONDITIONS AND NEW WORK
 FLOOR/SECTION: PHASE: DRAWING NO.:

E0.2.1

FEEDER IDENTIFICATION SCHEDULE		FEEDER IDENTIFICATION SCHEDULE	
TAG	WIRE (C) & CONDUIT	TAG	WIRE (C) & CONDUIT
3W20	3#12 & #12 G, 3/4"	4W20	4#12 & #12 G, 3/4"
3W25	3#10 & #10 G, 3/4"	4W25	4#10 & #10 G, 3/4"
3W30	3#10 & #10 G, 3/4"	4W30	4#10 & #10 G, 3/4"
3W35	3#8 & #10 G, 3/4"	4W35	4#8 & #10 G, 3/4"
3W40	3#8 & #10 G, 3/4"	4W37	4#8 & #10 G, 1"
3W45	3#8 & #10 G, 1"	4W40	4#8 & #10 G, 3/4"
3W50	3#8 & #10 G, 1"	4W45	4#8 & #10 G, 1"
3W55	3#8 & #10 G, 1"	4W50	4#8 & #10 G, 1"
3W60	3#8 & #10 G, 1 1/2"	4W57	4#8 & #10 G, 1"
3W70	3#4 & #8 G, 1 1/2"	4W80	4#8 & #10 G, 1"
3W80	3#2 & #8 G, 1 1/2"	4W81	4#8 & #10 G, 1 1/2"
3W90	3#2 & #8 G, 1 1/2"	4W90	4#2 & #8 G, 1 1/2"
3W100	3#2 & #8 G, 1 1/2"	4W82	4#2 & #8 G, 1 1/2"
3W100(1)	3#1 & #8 G, 1 1/2"	4W99	4#2 & #8 G, 1 1/2"
3W110	3#1 & #8 G, 1 1/2"	4W100	4#2 & #8 G, 1 1/2"
3W125	3#10 & #8 G, 2"	4W100(1)	4#1 & #8 G, 1 1/2"
3W150	3#10 & #8 G, 2"	4W107	4#1 & #8 G, 1 1/2"
3W175	3#20 & #8 G, 2"	4W110	4#1 & #8 G, 1 1/2"
3W200	3#20 & #8 G, 2"	4W125	4#10 & #8 G, 2"
3W225	3#40 & #4 G, 2 1/2"	4W150	4#10 & #8 G, 2"
3W250	4-250RCML & #4 G, 3"	4W157	4#10 & #8 G, 2"
3W300	4-300RCML & #4 G, 3"	4W175	4#20 & #8 G, 2"
3W350	4-350RCML & #2 G, 4"	4W200	4#10 & #8 G, 2"
3W400	4-400RCML & #2 G, 4"	4W225	4#400 & #8 G, 2 1/2"
3W450(1)	4-500RCML & #2 G, 4"	4W250	4-250RCML & #4 G, 3"
3W450	4-500RCML & #2 G, 4"	4W257	4-250RCML & #2 G, 3"
3W500(1)	4-500RCML & #4 G, 3"	4W300	4-250RCML & #4 G, 3"
3W500	4-500RCML & #2 G, 4"	4W350	4-500RCML & #2 G, 4"
3W600	4-600RCML & #4 G, 3"	4W400	4-600RCML & #2 G, 4"
3W700	4-700RCML & #4 G, 4"	4W400(1)	4-600RCML & #4 G, 4"
3W800	4-800RCML & #10 G, 4"	4W407	4-600RCML & #10 G, 4"
3W900(1)	4-900RCML & #10 G, 4"	4W450	4-900RCML & #7 G, 4"
3W950	4-950RCML & #2 G, 3"	4W450(1)	4-900RCML & #2 G, 2 1/2"
3W1000	4-950RCML & #10 G, 4"	4W500	4-950RCML & #2 G, 3"
3W1200	4-1200RCML & #1 1/2 G, 4"	4W507	4-950RCML & #1 1/2 G, 3"
3W1400	4-1400RCML & #40 G, 4"	4W600	4-1400RCML & #1 G, 3"
3W1600	4-1600RCML & #40 G, 4"	4W600(1)	4-1400RCML & #1 G, 3"
3W1800	4-1800RCML & #20RCML G, 4"	4W800	4-1800RCML & #10 G, 4"
3W2000	4-2000RCML & #20RCML G, 4"	4W800(1)	4-1800RCML & #10 G, 4"
3W2500	4-2500RCML & #20RCML G, 4"	4W907	4-2500RCML & #20 G, 3"
3W3000	4-3000RCML & #20RCML G, 4"	4W900	4-2500RCML & #20 G, 3"
3W4000	10-4000RCML & #20RCML G, 4"	4W1000	4-4000RCML & #20 G, 4"
		4W1000(1)	4-4000RCML & #20RCML G, 4"
		4W1200	4-4000RCML & #30 G, 4"
		4W1600	4-4000RCML & #30 G, 4"
		4W1800	4-4000RCML & #30 G, 4"
		4W1900	4-4000RCML & #250RCML G, 4"
		4W2000	4-4000RCML & #250RCML G, 4"
		4W2500	4-4000RCML & #250RCML G, 4"
		4W3000	4-4000RCML & #250RCML G, 4"
		4W3000	4-4000RCML & #250RCML G, 4"
		4W4000	10-4000RCML & #20RCML G, 4"

15:00/2010/09/21 11:00 AM

DRAWING NOTES:

- PROVIDE GROUND FAULT SENSING COIL FOR INDICATION ONLY. PROVIDE INSTRUCTIONS ON COURSE OF ACTION TO BE TAKEN IN THE EVENT OF AN INDICATED FAULT.
- PROVIDE DEVICES AND CONTROL WIRING REQUIRED FROM EXISTING FIRE PUMP CONTROLLER TO NEW EMERGENCY GENERATOR EG-1 FOR GENERATOR START SIGNAL. PROVIDE CONTROL WIRING IN DESIGNATED CONDUIT WITH ELECTRICAL DUCTWORK AS INDICATED.
- PROVIDE ELECTRONIC TRIP BREAKER WITH THE FRAME TYPE, TRIP RATING, AND ADJUSTABLE SETTINGS SHOWN. CIRCUIT BREAKERS SHALL BE BY SQUARE D OR APPROVED EQUAL.
- PROVIDE TYPE HD THERMAL MAGNETIC MAIN CIRCUIT BREAKER IN PANELBOARD. CIRCUIT BREAKERS SHALL BE BY SQUARE D OR APPROVED EQUAL.

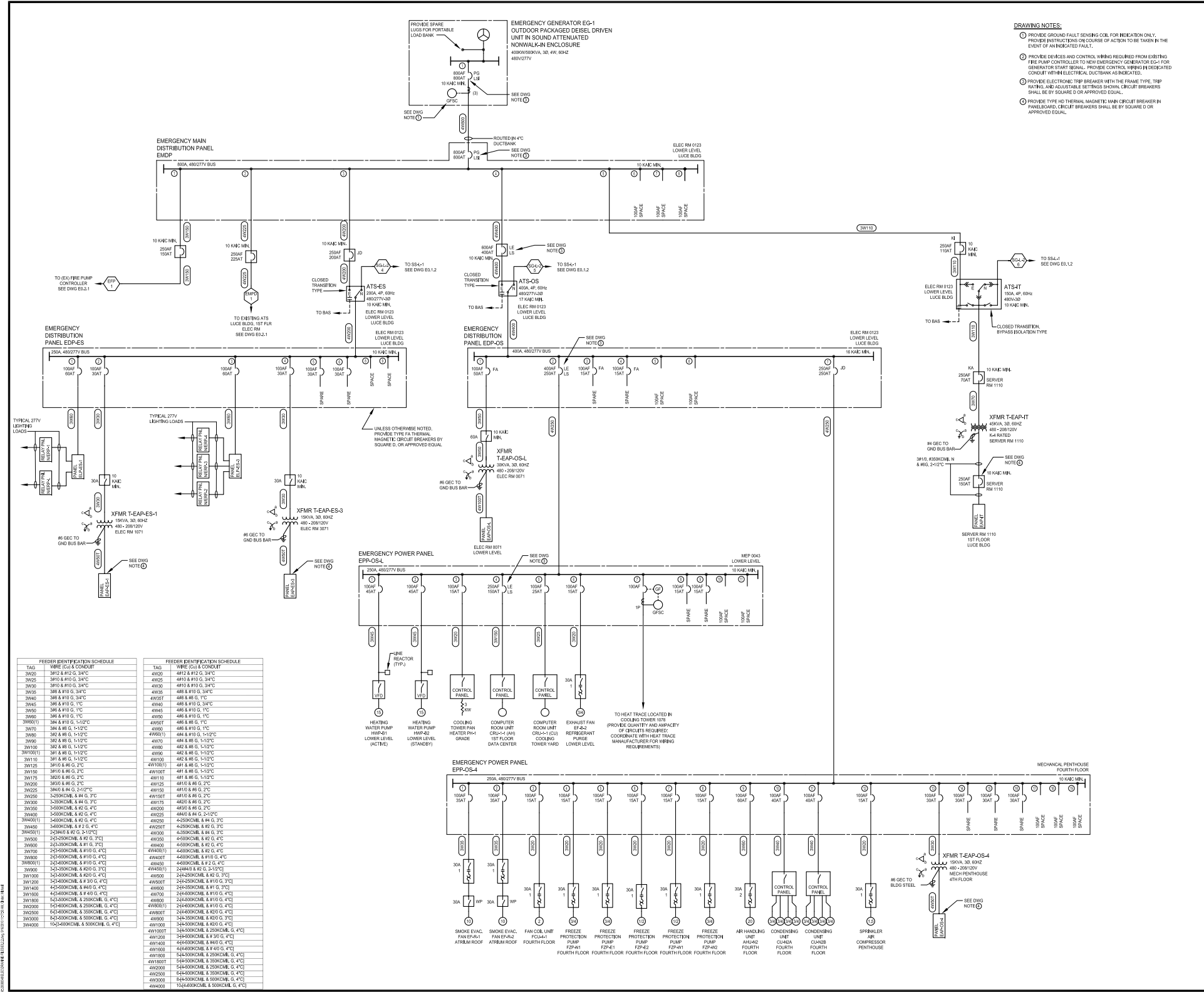

FEEDER IDENTIFICATION SCHEDULE	
TAG	WIRE COIL & CONDUIT
3W20	3#12 & #12 G, 3/4" C
3W25	3#10 & #10 G, 3/4" C
3W30	3#10 & #10 G, 3/4" C
3W35	3#8 & #10 G, 3/4" C
3W40	3#8 & #10 G, 3/4" C
3W45	3#8 & #10 G, 1" C
3W50	3#8 & #10 G, 1" C
3W55	3#8 & #10 G, 1" C
3W60	3#8 & #10 G, 1" C
3W65(1)	3#8 & #10 G, 1 1/2" C
3W70	3#8 & #10 G, 1 1/2" C
3W75	3#2 & #8 G, 1 1/2" C
3W80	3#2 & #8 G, 1 1/2" C
3W100	3#2 & #8 G, 1 1/2" C
3W100(1)	3#1 & #8 G, 1 1/2" C
3W110	3#1 & #8 G, 1 1/2" C
3W125	3#10 & #8 G, 2" C
3W150	3#10 & #8 G, 2" C
3W175	3#20 & #8 G, 2" C
3W200	3#50 & #8 G, 2" C
3W225	3#40 & #8 G, 2 1/2" C
3W250	3 1/2" 350KCMIL & #4 G, 3" C
3W300	3 1/2" 350KCMIL & #4 G, 3" C
3W350	3 1/2" 350KCMIL & #2 G, 4" C
3W400	3 1/2" 350KCMIL & #2 G, 4" C
3W450(1)	3 1/2" 350KCMIL & #2 G, 4" C
3W450	3 1/2" 350KCMIL & #2 G, 4" C
3W500(1)	2 1/2" 350KCMIL & #2 G, 2 1/2" C
3W500	2 1/2" 350KCMIL & #2 G, 3" C
3W600	2 1/2" 350KCMIL & #2 G, 3" C
3W700	2 1/2" 350KCMIL & #10 G, 4" C
3W800	2 1/2" 350KCMIL & #10 G, 4" C
3W850(1)	2 1/2" 350KCMIL & #10 G, 4" C
3W850	2 1/2" 350KCMIL & #10 G, 4" C
3W900	3 1/2" 350KCMIL & #20 G, 3" C
3W950	3 1/2" 350KCMIL & #20 G, 3" C
3W1000	3 1/2" 350KCMIL & #20 G, 3" C
3W1200	3 1/2" 350KCMIL & #30 G, 4" C
3W1400	4 1/2" 350KCMIL & #40 G, 4" C
3W1500	4 1/2" 350KCMIL & #40 G, 4" C
3W1800	5 1/2" 350KCMIL & #50 G, 4" C
3W2000	5 1/2" 350KCMIL & #50 G, 4" C
3W2500	6 1/2" 350KCMIL & #50 G, 4" C
3W3000	6 1/2" 350KCMIL & #50 G, 4" C
3W3500	6 1/2" 350KCMIL & #50 G, 4" C
3W4000	6 1/2" 350KCMIL & #50 G, 4" C
3W4500	6 1/2" 350KCMIL & #50 G, 4" C
3W5000	6 1/2" 350KCMIL & #50 G, 4" C
3W6000	6 1/2" 350KCMIL & #50 G, 4" C
3W6500	6 1/2" 350KCMIL & #50 G, 4" C
3W7000	6 1/2" 350KCMIL & #50 G, 4" C
3W7500	6 1/2" 350KCMIL & #50 G, 4" C
3W8000	6 1/2" 350KCMIL & #50 G, 4" C
3W8500	6 1/2" 350KCMIL & #50 G, 4" C
3W9000	6 1/2" 350KCMIL & #50 G, 4" C
3W9500	6 1/2" 350KCMIL & #50 G, 4" C
3W10000	6 1/2" 350KCMIL & #50 G, 4" C

FEEDER IDENTIFICATION SCHEDULE	
TAG	WIRE COIL & CONDUIT
4W20	4#12 & #12 G, 3/4" C
4W25	4#10 & #10 G, 3/4" C
4W30	4#10 & #10 G, 3/4" C
4W35	4#8 & #10 G, 3/4" C
4W40	4#8 & #10 G, 3/4" C
4W45	4#8 & #10 G, 1" C
4W50	4#8 & #10 G, 1" C
4W55	4#8 & #10 G, 1" C
4W60	4#8 & #10 G, 1" C
4W65	4#8 & #10 G, 1" C
4W70	4#8 & #10 G, 1 1/2" C
4W75	4#8 & #10 G, 1 1/2" C
4W80	4#8 & #10 G, 1 1/2" C
4W85	4#8 & #10 G, 1 1/2" C
4W90	4#8 & #10 G, 1 1/2" C
4W95	4#8 & #10 G, 1 1/2" C
4W100	4#2 & #8 G, 1 1/2" C
4W100(1)	4#1 & #8 G, 1 1/2" C
4W100T	4#1 & #8 G, 1 1/2" C
4W110	4#1 & #8 G, 1 1/2" C
4W125	4#10 & #8 G, 2" C
4W150	4#10 & #8 G, 2" C
4W175	4#20 & #8 G, 2" C
4W200	4#20 & #8 G, 2" C
4W225	4#20 & #8 G, 2 1/2" C
4W250	4 1/2" 400KCMIL & #4 G, 3" C
4W300	4 1/2" 400KCMIL & #4 G, 3" C
4W350	4 1/2" 400KCMIL & #2 G, 4" C
4W400	4 1/2" 400KCMIL & #2 G, 4" C
4W450(1)	2 1/2" 400KCMIL & #2 G, 2 1/2" C
4W450	2 1/2" 400KCMIL & #2 G, 3" C
4W500	2 1/2" 400KCMIL & #2 G, 3" C
4W600	2 1/2" 400KCMIL & #10 G, 4" C
4W700	2 1/2" 400KCMIL & #10 G, 4" C
4W750	2 1/2" 400KCMIL & #10 G, 4" C
4W800	2 1/2" 400KCMIL & #10 G, 4" C
4W850(1)	2 1/2" 400KCMIL & #10 G, 4" C
4W850	2 1/2" 400KCMIL & #10 G, 4" C
4W900	3 1/2" 400KCMIL & #20 G, 3" C
4W950	3 1/2" 400KCMIL & #20 G, 3" C
4W1000	3 1/2" 400KCMIL & #20 G, 3" C
4W1200	3 1/2" 400KCMIL & #30 G, 4" C
4W1400	4 1/2" 400KCMIL & #40 G, 4" C
4W1500	4 1/2" 400KCMIL & #40 G, 4" C
4W1800	5 1/2" 400KCMIL & #50 G, 4" C
4W2000	5 1/2" 400KCMIL & #50 G, 4" C
4W2500	6 1/2" 400KCMIL & #50 G, 4" C
4W3000	6 1/2" 400KCMIL & #50 G, 4" C
4W3500	6 1/2" 400KCMIL & #50 G, 4" C
4W4000	6 1/2" 400KCMIL & #50 G, 4" C
4W4500	6 1/2" 400KCMIL & #50 G, 4" C
4W5000	6 1/2" 400KCMIL & #50 G, 4" C
4W5500	6 1/2" 400KCMIL & #50 G, 4" C
4W6000	6 1/2" 400KCMIL & #50 G, 4" C
4W6500	6 1/2" 400KCMIL & #50 G, 4" C
4W7000	6 1/2" 400KCMIL & #50 G, 4" C
4W7500	6 1/2" 400KCMIL & #50 G, 4" C
4W8000	6 1/2" 400KCMIL & #50 G, 4" C
4W8500	6 1/2" 400KCMIL & #50 G, 4" C
4W9000	6 1/2" 400KCMIL & #50 G, 4" C
4W9500	6 1/2" 400KCMIL & #50 G, 4" C
4W10000	6 1/2" 400KCMIL & #50 G, 4" C

GENERAL NOTES:

- FOR SYMBOLS AND ABBREVIATIONS REFER TO DRAWING EG-1.
- FOR ACTUAL PHYSICAL LOCATION OF ELECTRICAL EQUIPMENT RESERVE WORK UNDER THIS PROJECT REFER TO PLANS AND DETAILS AS LISTED IN THE DRAWING INDEX.
- UNLESS OTHERWISE NOTED, ALL ELECTRICAL EQUIPMENT AND WIRING SHOWN IN A DARK, SOLID LINE ARE NEW WORK UNDER THIS PROJECT.
- JUNCTION AND PULL BOXES ARE NOT NECESSARILY SHOWN ON THE DRAWING AND SHALL BE PROVIDED WHERE NECESSARY AND BE IN ACCORDANCE WITH THE NATIONAL ELECTRICAL CODE AND INSTALLED WHERE REQUIRED.
- ALL SHORT CIRCUIT INTERRUPTING RATINGS SHOWN, WHETHER AC OR WA, ARE CALCULATED RATED SYMMETRICAL VALUES AT THE TERMINALS OF THE EQUIPMENT. THE WITHSTAND SHORT CIRCUIT CURRENT RATINGS OF PROTECTIVE DEVICES, TRANSFER SWITCHES, AND BUS BRACINGS SHALL BE EQUAL TO OR GREATER THAN THE VALUES INDICATED.
- UNLESS OTHERWISE NOTED, ALL CIRCUIT BREAKERS, MOTOR CIRCUIT PROTECTORS (MCP) AND SWITCHES ARE THREE (3) POLE.
- OVERCURRENT PROTECTION DEVICE TYPES, MODELS AND MANUFACTURERS INDICATED ON THE SINGLE LINE DIAGRAMS ARE INTENDED TO BE PART OF A SELECTIVELY COORDINATED SYSTEM IN ACCORDANCE WITH THE NATIONAL ELECTRICAL CODE (NEC) AND SPECIFICATION SECTION 26 07 00. THE SYSTEM SHOWN IS DESIGNED TO BE SELECTIVELY COORDINATED WITH THE BASIS OF DESIGN MANUFACTURER, SQUARE D COMPANY. ALL APPROVED EQUAL MANUFACTURERS SHALL MEET THESE REQUIREMENTS. A COORDINATION STUDY, IN ACCORDANCE WITH SPECIFICATION 26 07 00 IS REQUIRED TO DEMONSTRATE SELECTIVE COORDINATION. PRIOR TO APPROVAL AND RELEASE OF EQUIPMENT FOR FABRICATION.

KEY PLAN



PROJECT MANAGER
PATRICK BRUNNER
Engineering Leader
ROBERT GHISU
Project Designer
MICHAEL GLUNDER

REVISIONS

NO.	BY	DESCRIPTION	DATE

PRINCETON THEOLOGICAL SEMINARY LIBRARY
PRINCETON, NEW JERSEY
CONSTRUCTION DOCUMENTS

DRAWN BY: MG DATE: SEPTEMBER 21, 2010
PROJECT NO.: 20080648 SCALE: NONE
SINGLE LINE DIAGRAM - EMERGENCY - LIBRARY NEW WORK
FLOOR/SECTION: PHASE: DRAWING NO.: E0.2.2

Part 3 | Evaluation of Criteria vs. Current Design

This section compares the criteria above with the current electrical design of the building. Conclusions are drawn based on this information and suggestions made on how to improve the building's performance.

I. Building Loads

A comparison was conducted based on the estimated loads for this building type versus the actual connected loads. The actual load is approximately 4 W/sqft higher than the estimated load. This could be due to a few factors. The estimated information is based on an office building because there was not any data on libraries. Also, this library has a large server room and a large data load which is not typical.

Estimated

Lighting ~ 2.5 W/sqft

Receptacle and other ~ 1 W/sqft

Mechanical ~ 4.1 W/sqft

Special Equipment ~ 6 W/sqft

Total ~ 12.7 W/sqft

Actual

Total = 2279KVA ~ 16.7 W/sqft

II. Power Company Rate Schedule

Information concerning the actual rate schedule was requested from the building owner so an evaluation cannot be made. The chosen service voltage of 13,200/7,620V is suffice to serve the loads of the Princeton Theological Seminary Library.

III. Building Utilization Voltage

The building utilization voltage at 480/277V is a good choice based on the voltage of the existing loads. Changes could be made to the organization of the electrical power distribution that would provide some cost savings. Examples of such changes could include combining transformers that step down voltage from 480/277V to 208/120V for the panels in the electrical rooms. Another potential change would be to combine all the electrical and data rooms on each floor. Combining all this equipment into one big room versus lots of small ones would impact both the mechanical and structural loads. More air supply would be needed and floor support below these rooms would need to be reevaluated.

IV. Emergency Power System

The fuel and power source chosen for the emergency power system are sufficient for the loads and types of loads. Everything required by code in the building is on the necessary emergency power but the organization of the emergency power system is confusing. The loads are combined with the optional back-up loads and some of the emergency required equipment is on the optional back-up distribution panel.

V. General Equipment

Based on the comparison between the design criteria and the actual equipment used in the building, overall the equipment chosen serves the building well and makes sense. When comparing the priority assessment to the actual design some design choices stood out as agreeing with the importance mentioned above while others have room for improvement. In regards to flexibility and future expansion, by choosing to use double wide panelboards this allowed for an ample amount of open circuits. Initial cost was taken into consideration by reusing a lot of the existing panelboards, distribution panels and mechanical equipment in the Luce Building. Some equipment was also relocated and reused from the Speer Building into the new addition. Long term ownership cost was lowered with the implementation of solar panels to lower the energy cost. This also led to the decisions to tap into existing utilities and the steam loop that serves the campus.

The biggest suggestion for improvement would be to implement a UPS that will serve the loads in the server room and the computer loads. This will largely increase the reliability of the system and avoid losing vital information.

VI. Optional Back-up Power and UPS Systems

As mentioned above in the section giving suggestions on the emergency power system, the organization of the emergency power system and the optional back-up power should be reorganized and grouped based on which group the load falls into. The existing optional back-up power system supports some loads that do not necessarily need to be on back-up power such as the two condensing units. There are also loads that could benefit from being fed from a UPS which is a more reliable power source. The server room as well as the other panels serving computer loads would avoid losing information during a power outage if connected to a UPS instead of a generator.

VII. Cost Reduction Techniques

Combining equipment would save on initial cost and depending on the load it serves, improve the efficiency. This could apply to either the mechanical or electrical equipment but in order to evaluate whether this would reduce the cost of ownership, the existing and new equipment would have to compare initial and maintained cost based on the loads in the building.

VIII. Systems Integration

The fire alarm system could be integrated with telephone, intercom and/or CATV to send out an automated message alerting the occupants of an emergency situation. There would be a relatively small additional cost associated with this but the improvement in safety would most likely outweigh the cost. A BAS system used through the data connection would save energy by providing additional control of the mechanical and electronic systems. There would be an additional initial cost to implement the monitors and the software but the cost of this could be reasoned with a representation of the payback period of this equipment. Both of these integration techniques would increase the special equipment load in the building and might be added to the emergency or optional back-up power loads, potentially increasing the size of the generator or UPS.

IX. Energy Cost Savings and Energy Reduction Techniques

With the existing PV array, the environment is being utilized to save energy but additional energy savings techniques could be considered. Demand reduction and demand shifting would reduce energy consumption by turning off unused lights or equipment and producing cold water at off peak hours.