

Water for the World

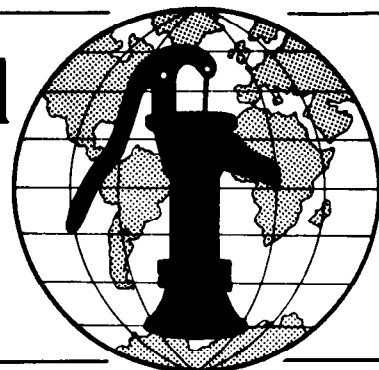

Designing an Elevated Storage Tank Technical Note No. RWS. 5.D.3

Elevated storage tanks are used to deliver water either through large distribution systems or through standpipes located at or near the source or at other communal watering points. Elevated storage tanks are used where ground storage tanks cannot be built due to lack of sufficient natural elevation and where standpipes are served from a well with a windmill or other powered pumps. Elevated tanks can serve either a large community or a small group of families. Elevated tanks do not have as large a capacity as ground storage due to the need for a tower structure to support the tank.

This technical note discusses the design of elevated storage tanks and offers suggestions for choosing the appropriate tank design and construction materials. Read the technical note carefully and adapt the suggestions to local conditions to ensure that the storage meets users' needs.

The design process should result in the following three items which should be given to the construction supervisor.

1. A map of the area showing the location of the storage tank in relation to the water source and the community. Include important landmarks, elevations, if known, and distances on the map. Figure 1 gives an example of the type of map which should be provided.

2. A list of all labor, materials and tools needed. The list will help make sure that adequate quantities of materials are available to prevent construction delays. See Table 1 for a sample materials list for an elevated ferrocement storage tank.

Useful Definition

HEAD - Difference in water level between the inflow and outflow ends of a water system.

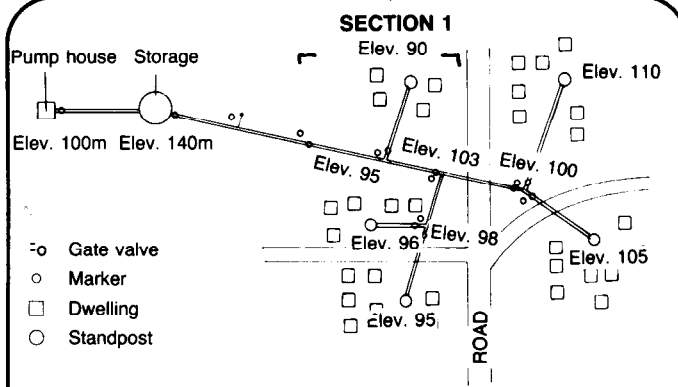

Figure 1. Design Map of Storage and Distribution System

Table 1. Sample Materials List for Elevated Ferrocement Storage Tanks

Item	Description	Quantity	Estimated Cost
Labor	1 Foreman 6-10 Workers	_____	_____
Supplies	Cement Weld mesh 0.15m, 5mm diameter, 4m x 2m sheets Woven mesh 0.2m openings, 30m long, 1m high Sand Gravel Timber and plywood for roof Bricks Lime Pipe, PVC or steel for inlet and outlet Wire screening Valves Nails Pipe glue	_____ _____ _____ _____ _____ _____ _____ _____ _____ _____ _____ _____ _____ _____ _____ _____	_____ _____ _____ _____ _____ _____ _____ _____ _____ _____ _____ _____ _____ _____ _____ _____
Tools	Shovels Pliers Wire cutters Wrenches, adjustable and open Mortar box Hoops Hack saw Hammer Screwdriver Measuring tape Plumb bob	_____ _____ _____ _____ _____ _____ _____ _____ _____ _____ _____ _____ _____	_____ _____ _____ _____ _____ _____ _____ _____ _____ _____ _____ _____ _____

Total Estimated Cost = _____

3. A plan of the storage reservoir with dimensions shown as in Figure 2. The plan shows a side, front and top view.

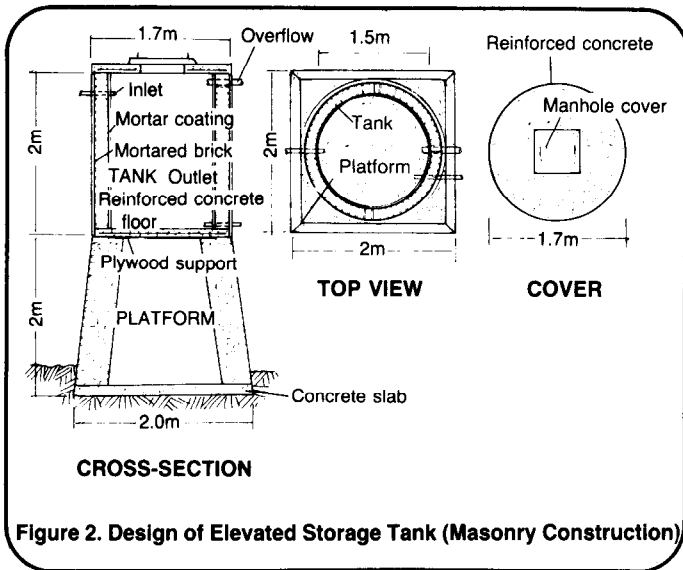

Figure 2. Design of Elevated Storage Tank (Masonry Construction)

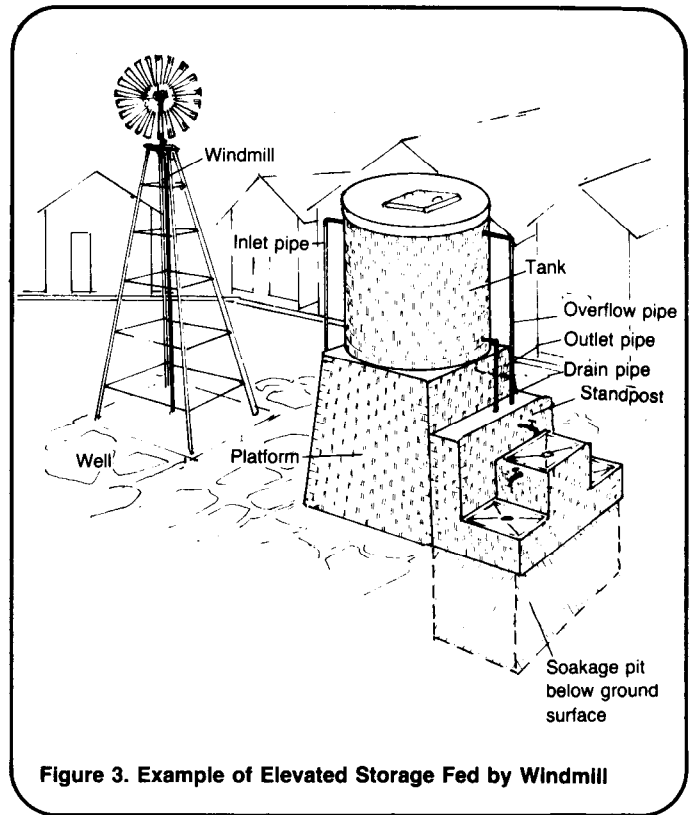

Figure 3. Example of Elevated Storage Fed by Windmill

Choice of Storage Tank

The choice of the best type of elevated tank to use depends on the type of system being installed, the materials available for construction and the availability of skilled labor. Elevated storage tanks are useful for providing water to standpipes as shown in Figure 3 and to large distribution systems are shown in Figure 4.

Elevated tanks which serve standpipes generally have small capacities and are supported by small towers. The towers are usually made from brick or masonry and have a height of 1-3m. Steel and wood can be used although steel is expensive and wood is less durable than other materials. The base of the tower should be at least 1.2 times wider than the top. Since not much head is needed to serve standpipes, the height of the tower does not have to be great. Shorter towers require less material which reduces cost. Determine the size of the tower desired and the design which uses the fewest bricks. Figure 5 shows one design. Approximately 50 bricks are needed for each m² of construction. If possible, use wide bricks to form a wall 100-150mm thick. A design using four walls that come together at a

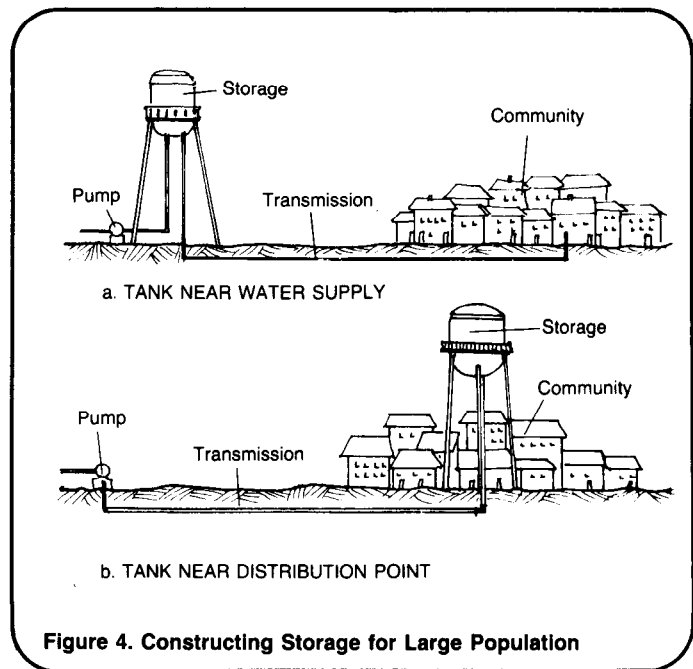

Figure 4. Constructing Storage for Large Population

center point is useful and effective. The base should be well designed and constructed to ensure adequate strength to support the water tank. Before designing an elevated tank, consult an engineer or someone with experience in designing water tank bases.

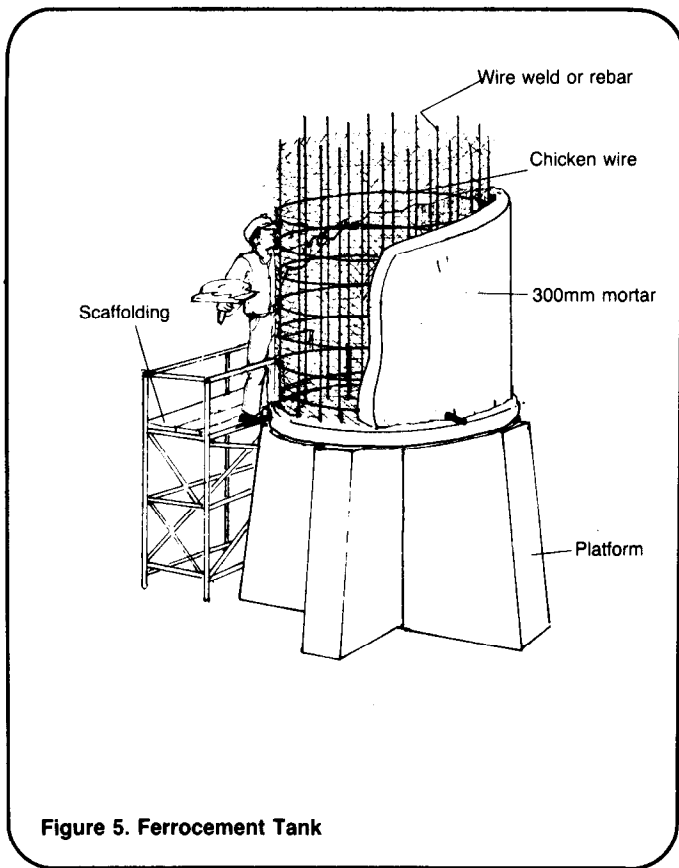

Figure 5. Ferrocement Tank

To choose the type of tank, first determine the capacity needed. The capacity can be found by multiplying the number of users by the per capita consumption per day. When water is distributed from a standpipe, an average estimate of water use is 15 liters per capita per day, lpcd, as shown in Table 2. If animals will be watered from the public supply, their rate of consumption should be included as shown in Table 3.

Table 2. Estimated Water Consumption

Type of Water Supply	Average Water Consumption (Liters/Capita/Day)	Range (Liters/Capita/Day)
Community water point (i.e., well, spring, public standpipe)		
At distance 1000m	7	5-10
At distance 500-1000m	10	8-12
Village well (250m)	12	10-15
Standpipe (250m)	15	10-20
Yard connection or single tap	40	20-60
House connection (multiple taps)	70	50-120 (or more)

Table 3. Population Growth Factors

Design Period Years	Yearly Growth Rate (%)					
	1.5	2	2.5	3	3.5	4
7						
10	1.1	1.15	1.19	1.23	1.27	1.32
15	1.16	1.22	1.28	1.34	1.41	1.48
20	1.25	1.35	1.45	1.56	1.68	1.80
25	1.35	1.49	1.64	1.81	1.99	2.19

For example, if several standpipes with one reservoir serve a small community of 200 people and no animals and water consumption is 15 lpcd, the total daily consumption is 3000 liters. Assume a peak demand of 20 percent of total daily demand for storage purposes and design the storage tank for 3000 liters + 20 percent x 3000 liters or 3000 liters + 1.2 x 3000 liters = 3600 liters. The tank should have a minimum capacity of 3600 liters. Assuming some growth in population and an increase in demand, the total capacity should be at least 4000 and possibly even 5000 liters. Table 3 provides population growth factors for different design periods.

Where the population is spread out, more than one elevated tank with standpipes in several locations can be constructed. The capacities of these tanks can be smaller. This type of elevated tank can receive water from a well via a windmill, a simple gravity flow system if the terrain permits, or a hydraulic ram. If pumps powered by electricity or petrol are used, larger storage tanks are recommended.

One of the cheapest and easiest materials to use for a small capacity tank is steel. Pressed steel plates can be bolted together on top of a tower with little or no skilled labor. Tank size will be influenced by the amount of water that needs to be stored and the size of pressed steel sheets available. A tank using pressed sheets 1.6m x 1.6m x 1.6m will provide a storage capacity of just over 4000 liters.

If steel tanks are impossible to obtain or are very costly, a storage tank can be constructed using brick masonry or ferrocement. Elevated ferrocement tanks are best when they are small diameter circular tanks with relatively small capacities. A circular ferrocement tank similar to the cistern described in "Designing a Household Cistern," RWS.5.D.1, can be constructed on a raised tower. A small, 4-6m³, capacity ferrocement tank can be built on the tank tower without using formwork. An initial circle of bricks forming the outside diameter of the tank should be placed so that the floor diameter is 1.5-2m. A weld and chicken wire mesh cylinder 3m high should be assembled as shown in Figure 5. The tank itself should be only 2m high; the extra wire mesh is used for roofing. Table 1 is a sample list of materials for this kind of tank.

Once the mesh is assembled, mortar mixed in a proportion of 1 part cement to 3 parts sand is applied in a coat 300mm thick. Inlet, outlet and overflow pipes should be installed. The inlet should enter the top of the tank while the screened outlet should be at the bottom.

Brick masonry tanks can be constructed upon the tower itself. Special care should be taken to ensure that the tank is water-tight by coating the inside with a layer of mortar. Construction follows the basic steps for masonry tanks. For small water storage tanks, a circular tank design as shown in Figure 5 is recommended. The mortar between the bricks or rocks should be mixed in the ratio of 1 part cement to 4 parts sand. If sand is not of good quality, then a ratio of 1:3 may be used. To strengthen the mix, lime can be added to the cement in a proportion of 1 part lime to 5 parts cement. Lime is especially useful when mortar is being mixed for brick-laying. The mortar used to line the inside walls of the tank does not require lime. Two coats of mortar each 150mm thick should be applied to the inside of the tank. To give the tank and tower a good finish a 200mm layer of mortar should be applied to the outside of the tank and tower if resources permit.

An inlet pipe should be attached to the tank so that it enters near the top. See Figure 2. A screened outlet leads from the bottom of the tank to the standpipe connections. The screen strains out sediment that collect on the tank bottom. An overflow should be installed near the very top of the tank.

Large Capacity Tanks

Large capacity elevated tanks for more populated communities are generally made of steel or reinforced concrete. Figure 4 shows a typical reinforced tank while Figure 6 is a steel tank. Steel tanks raised on steel platforms are generally paid for by national water authorities or governments. They are very expensive and generally must be imported. The choice to use this type of tank depends on whether they are manufactured in the country or can be acquired at an appropriate price.

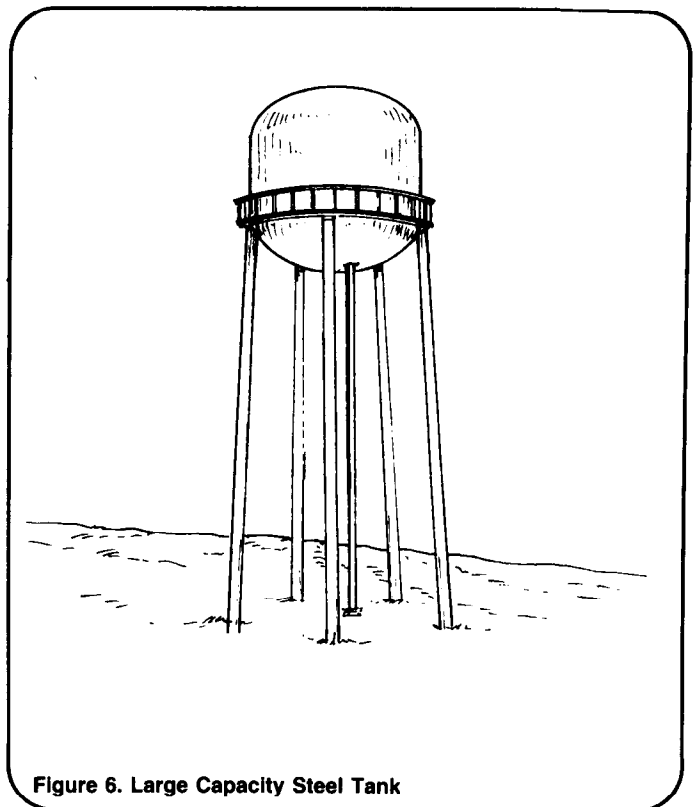

Figure 6. Large Capacity Steel Tank

Reinforced concrete tanks are more commonly used than steel tanks. Their construction requires cement and other materials which may be available nationally or else must be imported. If a tank of standard design is manufactured, the forms used in building the first tank can be reused in constructing later tanks and will result in lower construction costs. Furthermore, local employment opportunities will be created and the local economy will be helped by increased incomes. An elevated reinforced concrete tank should not be constructed without an engineer. Tanks must be well designed to work efficiently and a great deal of expertise is needed in construction. An engineer should be at the construction site to supervise all construction and no work should be done without expert advice.

The decision to use an elevated tank is a result of the need to provide sufficient head in the system. The water level in the tank must be higher than the highest tap in the system so that tap has enough discharge pressure. To provide 14m of pressure in the system, the water in storage should be more than 14m above the height of the highest tap. Consult an engineer when determining minimum and maximum heights for the storage reservoir.

Capacity. The capacity of the storage tank is important to the efficient operation of a water supply system. It should be large enough to store sufficient water to meet both average and peak daily demands. When designing a storage tank, keep in mind that demand for water varies during the year. In the hotter months, people use more water than in cooler months and on certain religious or cultural occasions water use may increase.

The first step in determining storage capacity is calculating the demand for water in the community. Follow the steps below in estimating demand.

1. Determine the population of the community. Use census data or initiate a survey to obtain population figures. Check past records to determine the rate of population growth over the

years. If funds permit, the storage tank should be designed to last for twenty years. Therefore, use the estimated population for twenty years in the future to determine demand for water. Use the growth factors in Table 3 when estimating future population.

For example, the present population of a community is approximately 1300 and it has been growing at a rate of 3 percent per year. To determine the population in twenty years, multiply 1300 by the population growth factor 1.81 found in the row marked 20 and the 3 percent column in Table 3.

$$\text{Population} = 1300 \times 1.81$$

Population = 2350 or approximately 2400.

The reservoir should be designed for a population of 2400 people.

2. Once the population is known, the demand for water can be calculated. Demand can be estimated by considering the type of distribution system used. Table 2 shows estimated water consumption rates for different types of distribution arrangements. Another important factor affecting demand is the use of water for purposes other than household drinking and cleaning. If the community has hotels and restaurants or if animals will be watered from the public system, consumption figures would reflect these uses. Table 4 shows estimated water use for various institutions and for animals. Use these figures when designing the capacity of the reservoir.

The total daily demand for water can be calculated using Worksheet A. The calculations are done for a population of 2400 people in a town that has a small hospital with twenty beds, one hotel for 75 people and two schools. A large chicken farm with 5000 chickens also uses water from the public system. It is estimated that 40 percent of the population will be served by multiple taps, 35 percent by single taps in the yard and 20 percent by standpipe. Five percent will have no service.

Table 4. Water Use Requirements

Category	Typical Water Use (Liters/Day)
Schools	15-30 per pupil
Hospital	
(with laundry)	200-300 per bed
(without laundry)	120-220 per bed
Clinics	15-30 per patient
Hotels	80-120 per guest
Restaurants	60-90 per seat
Office	25-40 per person
Bus Station	15-20 per user
Livestock*	
Cattle	25-35 per head
Horses and Mules	20-25 per head
Sheep	15-25 per head
Pigs	10-15 per head
Poultry*	
Chickens	0.15-0.25 per head

*If at all possible, use of water from a public supply for livestock and poultry should be avoided.

3. Once the total daily demand is determined, peak demand should be considered. Peak demand is the highest rate of demand during the day. Usually peak demand occurs during the morning when people get up to begin the day and in the early evening after work is completed. Peak demand is estimated by adding 20-40 percent to average daily demand. Multiply average daily demand by 1.2 or 1.4. For example,

$$\text{Average day} = 120000 \text{ liters/day}$$

$$\text{Peak day} = 1.2 \times 120000 = 144000 \text{ liters/day.}$$

A general rule to follow is that the capacity of the storage tank should be 20-40 percent of the peak day water demand. With a peak daily demand of 144000 liters, the capacity of the tank should be at least 30m³; 144000 liters x .2 = 30000 liters. At the 40 percent value, the tank would be 58m³; 144000 liters x .4 = 58000 liters. In this case, a reservoir of between 40-50m³ would be needed to meet peak demand.

Structure Design. Large capacity reinforced concrete tanks should be designed by engineers to ensure that the structure is sound. A typical tank is elevated on a tower made of reinforced concrete with a tank built as a continuation of the supporting structure. Large quantities of material are

Worksheet A. Calculating Water Demand

Population 2400	
1. Multiple taps in homes of 40% of population 40% x 2400 x 70 lpcd	67200
2. Single tap in yards of 35% of population 35% x 2400 x 40 lpcd	33600
3. Standpipe for 20% of population 20% x 2400 x 15 lpcd	7200
4. Two schools with 500 students 1000 x 20 lpcd	2000
5. Chickens (5000) 5000 x 0.2 lpcd	1000
6. Hospital with 20 beds without laundry 20 x 160 lpcd	3200
7. Hotel 75 guests 75 x 75 lpcd	5625
Total	119825

required for building the tank. The community should be sure that all materials can be obtained before deciding to construct such a tank.

The below ground base, the legs of the tower and cross pieces should all be reinforced using at least 8mm diameter reinforcing rods. A larger diameter rod may be preferable if it is available at a cost that is not too high.

The inlet and outlet pipes should be connected as described for smaller tanks. The outlet pipe should be screened to prevent sediment from entering the distribution system. A tight-fitting cover should be placed at the top of the tank so the tank can be entered for cleaning. A ladder on the outside of the tank gives access to the manhole. A small ladder or rings should be placed on the inside of the tank so people can enter safely.

Summary

There is little chance that a community can build a large capacity elevated storage tank without outside technical and financial assistance. Such tanks are recommended for use only when these resources are easily available to the community. Smaller elevated tanks, as described in the earlier section of this paper, can be built with local supplies and labor with minimal outside assistance. The choice of storage tank design should be made only after careful consideration of the needs of the community and the resources available.