

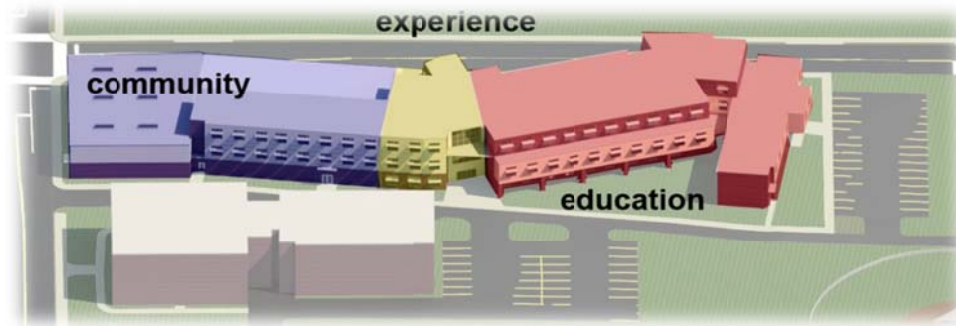

Submission Category: Mechanical Systems
Date: 14 December 2012

Content



The requirements of a typical elementary school, in conjunction with the socioeconomic conditions of the Reading school district necessitated unique design decisions and innovative solution. To achieve this, a set of categories was created to define the purpose of each space in the school. It was determined that the three major functions of the building included **Experience, Community, & Education** spaces. The function of these three unique spaces dictated the integrated design of the various building systems. This too, became the manner of dividing the building in terms of system types and discipline coordination. As such, these will be the key areas of discussion and integration in the following content.

▼ <u>Executive Summary</u>	2
○ Introduction	2
○ Mechanical Design Goals	3
▼ <u>Narrative Description of Systems/Solutions</u>	4
○ Building Envelope	4
○ Heat Recovery	4
○ Dehumidification/Humidification	6
○ Heating, Ventilation, Air Conditioning	6
▼ <u>Rationale for System Selection/ Solutions</u>	9
○ HVAC & Heat Recovery	9
○ Equipment Configuration	9
○ Specific Space Considerations	12
▪ Experience	12
▪ Community	12
▪ Education	13
○ Cost	13
▪ Upfront Cost	13
▪ Total Equipment Cost	14
▼ <u>Concluding Summarization</u>	15
▼ <u>Appendix</u>	16

Executive Summary:

1.1 Introduction

In designing a mechanical system for the Reading Elementary School many socioeconomic, constructability, and feasibility factors were taken into consideration. Our preliminary calculations presented us with a 70,000 cfm and 190 ton load requirement for the building. The design too needed to take into consideration the requirements of the other disciplines: Structural, Lighting/Electrical, & Construction. As such, it was determined that an Ethylene-Glycol recovery system be implemented to design the most cost effective system in terms of upfront and lifecycle costs while integrating well with other discipline requirements.

The recovery system manufactured by Konvekta was used in the determining the efficiency and cost analysis of this system as it was found to be the most efficient form of recovery at 65% recovery with the addition of the pool and 60% without the pool. This allows for drastic energy savings in short and long run cost analysis. There will be an increase in mechanical upfront cost of about 20-30%. However, this increase will be offset by a 3-5 year payback period due to the system efficiency. The system too will be a 100% outdoor air system to allow for maximized ventilation rates and an overall improved internal environment. This will earn the LEED Credit for 30% increase in the ASHRAE baseline ventilation requirements.

As the primary conditioning season for the school is during the heating season, it was determined to utilize a system that would recover as much of the thermal exhaust energy as possible and reintroduce it as preconditioning for increased energy savings. It was also crucial to implement a mechanical system that did not impact construction time and had quantifiable savings in terms of initial costs. The largest design challenge was undoubtedly the pool as it is being specified as an alternate phase to the owner. This required a system with flexibility so that the pool could be added at a later date in addition to being able to recover as much latent and sensible heat as possible for reimplementation to this zone.

The Ethylene-glycol recovery system was thus chosen as it is much more efficient in terms of energy recovery than a typical recovery system. It is a packaged system that does not impact construction schedule and allows for a flexible layout. The distinct configuration of the Konvekta module provides a truly unique and optimized system in terms of heat recovery. The system is also capable of adding zones; as the pool phase may be incorporated into the existing system at a later date. The system too incorporates a dehumidification loop to recover latent heat in addition to vast sensible recovery capabilities mentioned above.

Overall, the Ethylene-Glycol system is a unique system for achieving our heat recovery requirements and proves to be a very effective and efficient solution to the challenges presented by the Reading Elementary School. The product has a guaranteed success rate of implementation by Konvekta as well; which proves to the owner that the investment in this technology will be beneficial over the building's lifecycle. Overall, the system does a great job of fulfilling all of the owner requirements for the building in addition to the requirements specified by the other design disciplines and the overall Nexus team goals. Thus this design will provide the optimum efficiency, value, and return on investment to the owner and the reading school district while providing a building that facilitates the education of its students.

1.2 Mechanical Design Goals:

In calculating the socioeconomic barriers presented by the Reading School District it was determined that the mechanical system be both cost effective and efficient in terms of upfront and lifecycle costs. These aspects are derived from the overall team nexus goals. The biggest challenge for selecting and designing a mechanical system became finding a balance between initial cost and lifecycle return. As a team, Nexus developed three main goals to use achieve these design criteria:

reduce, recover, reuse



Reduce: A reduction of loads will allow for the downsizing of equipment; ultimately resulting in lower upfront cost and less energy consumption. For this to happen there must first be a reduction in energy leaving the building. Several static design considerations will be implemented to impede the loss of these energies. It too was determined that a key aspect of the design was selecting an application that would maximize system and overall constructability to decrease costs via a reduction of schedule. Lastly, a reduction in maintenance and operation costs will too be crucial in optimizing lifecycle sustainability.

Recover: This refers to the capturing of energy that cannot be reduced in our system design and prevent it from being lost or wasted to the surrounding environment. The building contains specific zones with very different conditioning considerations; two of which being the pool and kitchen. It is crucial that the mechanical system design develops a way to capture that heat from dissipating from these high heat spaces. This holds true for not only the conditioning aspects of the mechanical system but also for the plumbing design as well. Through the recovery of gray water it is possible to reduce the costs associated with the rate of water consumption in the building.

Reuse: This obviously plays directly into the aforementioned goal of recovery. By recovering the excess energy being lost and reimplimenting it into the system will greatly impact the building's lifecycle cost. This can be achieved through different types of heat recovery devices that use methods of absorbing and rejecting heat to precondition outdoor air. As such, several opportunities to reintroduce recovered energy will be investigated in order to allow for the most cost effective system. Additionally opportunities to reintroduce recovered resources into the building systems will also be investigated such as gray water reuse.

As an integrated design team, Nexus feels that these three goals are crucial to the success of our design in terms of meeting the owner's needs. The implementation of a thoroughly designed and sustainable system will add a tremendous value to the building. It is our goal to not only meet but surpass these goals in our final design. Through these objectives, the mechanical system design will save money for the community both in the upfront costs of construction in addition to the lifecycle energy consumption of the building. This will thus play a significant role in the overall packaged product of our building. As Team Nexus, the design of the Reading Elementary School will fully integrate these sustainable mechanical objectives with those of the other disciplines and building.

2. Narrative Description of Systems/Solutions

2.1 Building Envelope

The first step in the mechanical design process was to create a mass model and analyze the site conditions to generate a basic energy model (as shown in Figure 1). This was done using Project Vasari, and allowed us to develop static mechanical designs to optimize the envelope of our building with considerations to specific to our site layout.

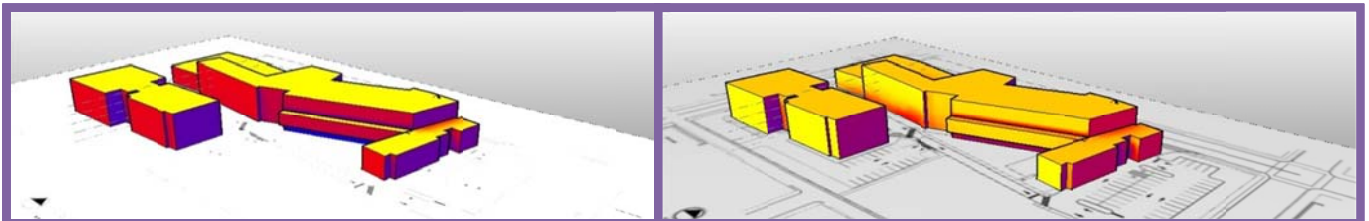

Figure 1: Vasari Model showing solar radiation on building envelope in summer (left) & Winter (right)

Using these modeling outputs in cohesion with the ASHRAE 2010 design criteria, it was determined that an ICF (Insulated Concrete Form) exterior wall construction be implemented to provide an R value of 24. This too surpasses the ASHRAE minimum R-Value for Climate zone 5 by almost 20%. Special considerations were also taken into the glazing design for the building. The design goals of the Lighting/Electrical engineer required that the building utilize as much natural daylighting as possible. In working with the lighting designer a standardized window system was developed with a U-value of 0.28. It too should be noted that this glazing configuration comprises less than 30% of the entire exterior surface area which is well under the ASHRAE 2010 maximum design criteria of 40%. The ICF façade system too provides a tighter seal than most façade systems which will help to reduce the infiltration of thermal conditioning to the environment.

2.2 Heat Recovery:

As stated in the aforementioned mechanical goals, recovering lost energy is considered one of the most important design criteria. Therefore and Ethylene Glycol runaround system was selected to be the best system to handle our building needs. The system specified by our design is one made by Konvekta and started being used in applications in the United States for the past 5 years. The system works in the manner of a traditional runaround system by capturing thermal energy from the exhaust air and reintroducing it to precondition incoming outdoor air (As shown in figure 2).

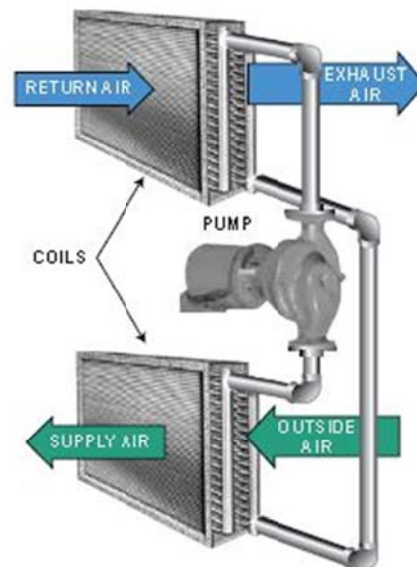

Figure 2: Traditional Runaround System
<http://www.dac-hvac.com/blog/page/3/>

There are three components of the Konvekta run-around system that make it more 20-30 % more efficient than a typical run-around recovery system. This allows Konvekta's system to recover 60 – 90% of energy that escapes the building in exhaust. This differs greatly from the 40-60% of energy recovered via a traditional runaround system. These three differentiating components are as follows:



Figure 3: Konvekta Counter flow Coil
www.dac-hvac.com/blog/

1) Konvekta's Coil Array:

- Traditional systems use water with some form of an anti-freezing agent as the medium in which they transfer the thermal energy. These additives diminish the water's heat transfer capabilities to around 40-50%. Utilizing the ethylene glycol solution is better than these typical solutions by about 20%.
- In addition Konvekta's coil array is 10% more efficient than a typical flat plate heat exchanger. The array utilizes a double header, thick, wide-spaced, fin design that maximizes counter flow. It also offers a small air-glycol approach temperature to maximize heat transfer. (as shown in Figure 3)
- From a maintenance perspective the entire depth of the coil is accessible for ease of cleaning.

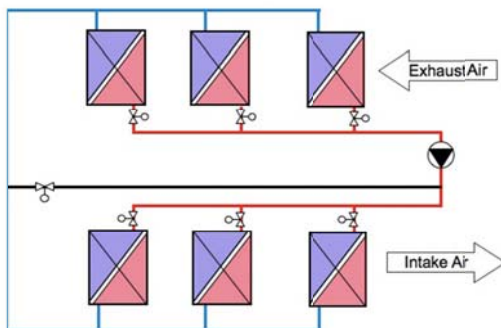

Figure 4: Konvekta "Gang" configuration
www.konvekta.ch

2) Piping/Flow Configuration

- traditional runaround uses 1 or two units on the loop with constant flow of heat transfer fluid
- Konvekta utilizes a **Gang system** (as shown in Figure 4) that allows multiple exhaust units on one loop with control valves at each unit. This allows for variable flow to optimize heat transfer between exhaust and glycol solution. The centralized pumping system then takes all of this pretreated solution and distributes it to the OA units for preheating/cooling in the same manner.

3) Control System

- These controls match delta T between OA and EA with the variable flow valves at each unit in order to optimize heat transfer performance with glycol solution.
- Integrates with air handler controls for variable air flow across coils as well in order to match ventilation requirements.
- Also assesses energy savings in addition to having pressure drop alert systems for potential leakages etc. (Ethylene glycol has less chances of leaking due to its viscosity and surface tension)

Overall this system allows for a heating energy recovery of about 65% (with the pool, 60% without). As the school is primarily being used in the heating season, this will provide tremendous savings to the owner and community in lifecycle costs.

2.3 Dehumidification/Humidification:

In designing our system and speaking with industry professionals we found that the high humidity in the exhaust air allows a high heat recovery rate without the need to excessively cool the exhaust air. This will cause some condensation in the exhaust air coils so they will implement an epoxy coating. The other aspect that makes this system very efficient is its efficiency at partial load supply. This is a result of the reduced airflow which allows the maximum transfer of thermal energy

to precondition the outdoor air. In continuing with the pool the Konvekta system also utilizes a dehumidification circuit that will allow the system to handle the high latent loads being produced by the evaporative effects of the pool; as shown in Figure 5.

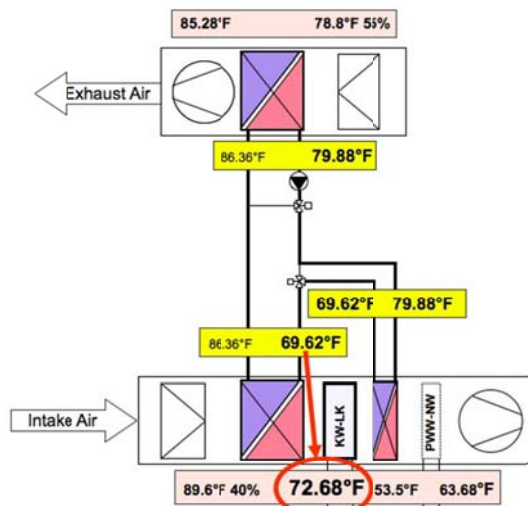

Figure 5: Konvekta Dehumidification Loop
www.konvekta.ch

The heat exchanger on the intake side has two parts, the first will cool the intake air, thus dehumidifying it and the second part will be reheated using the runaround loop to bring it up to the required supply temperature. This allows for a reduction in the peak cooling load of the chiller and will require smaller chillers that will consume less energy as they will operate at a higher level of efficiency.

2.4 Heating, Ventilation, & Air-Conditioning Design

As discussed above our building is broken into three parts: Experience (Lobby & Admin), Community (Pool & Gym), and Education (Classrooms). As such our systems correspond to the same separation of building zones. Mechanically speaking, the building too was broken up into three zones: Academic (right wing), Community (left wing), and Pool. (As shown in Figures 6-8 below). Each of these three zones is conditioned individually by their own Outdoor Air unit and Exhaust unit as per the Ethylene Glycol Runaround system. This presents a total of 3 Outdoor Air units and 3 Exhaust units to condition this entire building

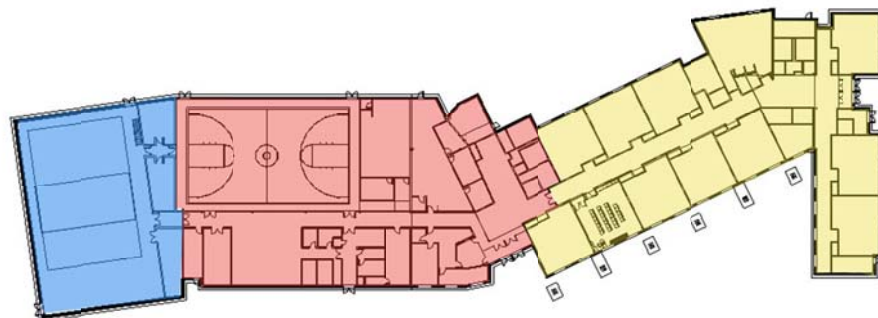

Figure 6: First Floor Plan 3 Zone Diagram: Pool (Blue), Community (Red), Classrooms (Yellow).

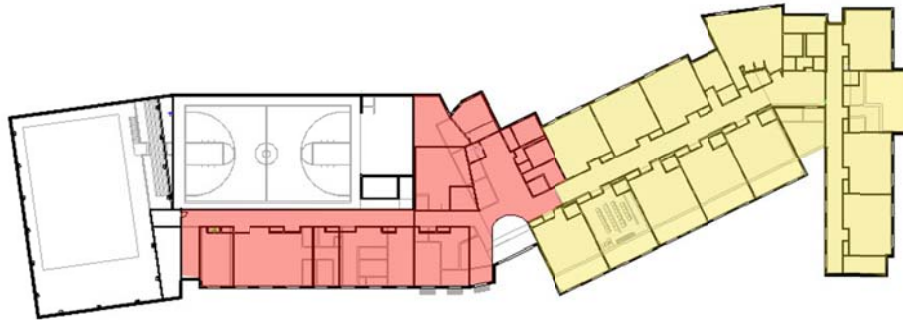

Figure 7: Second Floor Plan 3 Zone Diagram: Community (Red), Classrooms (Yellow).

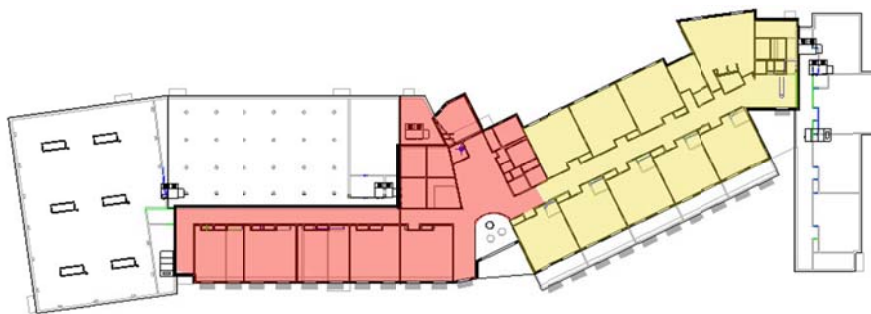

Figure 8: Third Floor Plan 3 Zone Diagram: Community (Red), Classrooms (Yellow).

The reason that this zone configuration slightly deviates from the breakdown of the three overall “Nexus Spaces” is a result of the pool. Obviously the pool presented the most mechanical challenges in terms of conditioning and exhausting. Examples include the specific coils and air handlers that have protective coatings from the chemical vapors being exhausted. The major reason however, for separating this space into its own zone is because the pool is being proposed as an add-alternate to the owner. This means that the Outdoor Air unit and Exhaust Unit for this zone can be incorporated into the Ethylene Glycol Runaround system at a later date. Should the owner decide not to include the pool, the building will be conditioned on the 4 remaining air handlers from the Yellow and Red Zones.

These six air handlers will all be placed on the roof of the second story. This will allow for easy access from the third floor for any maintenance that may occur in the future. This layout can be shown in Figure 9. Each of these units will be connected to each other via the runaround system a schematic of which can be shown below in Figure 10.

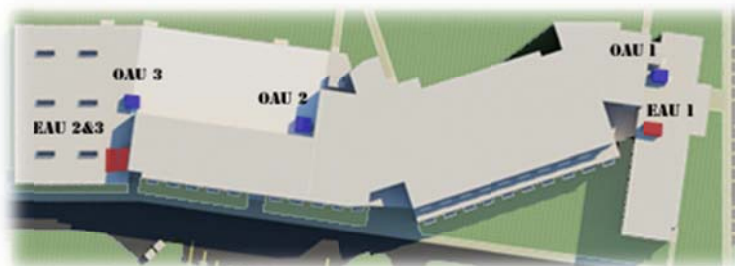

Figure 9: Air handler Layout on Second Floor Roof

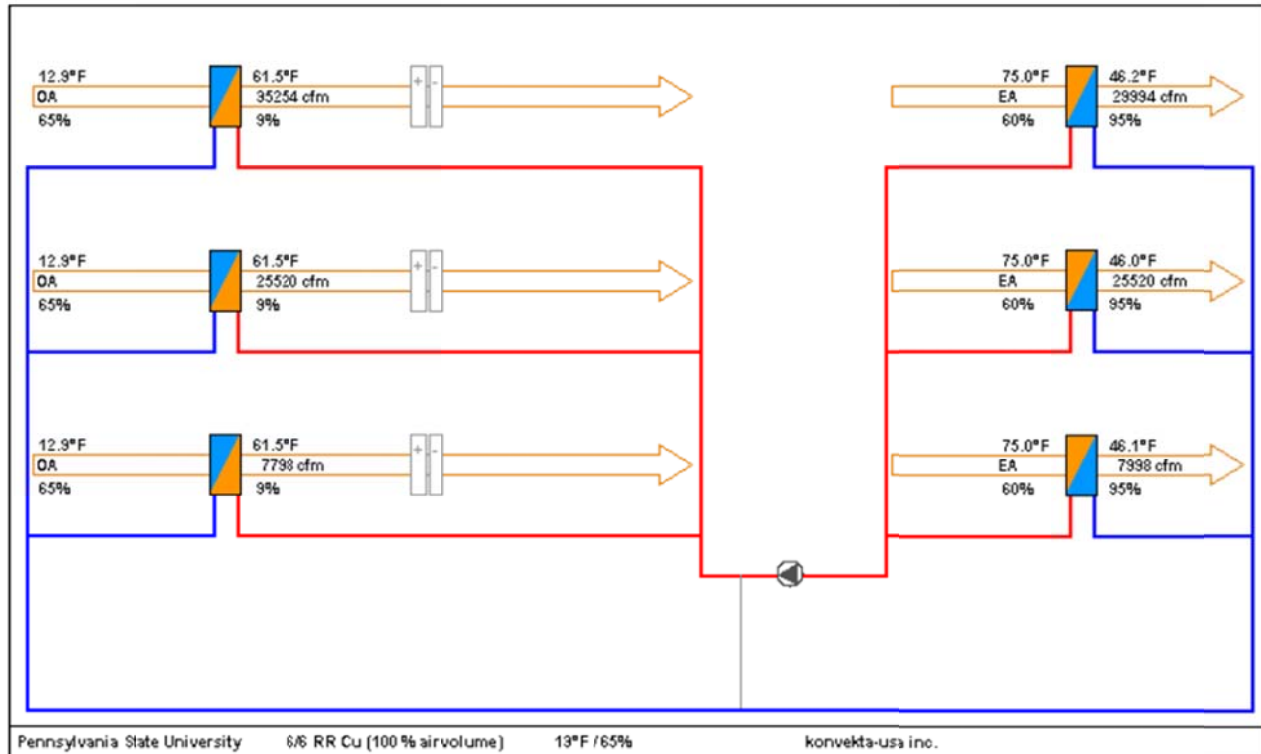

Figure 10: Air handler Runaround configuration at 100% Air Volumes

To more accurately analyze the loads in our building, an in-depth energy model was done using Trane Trace 700. Trane Trace 700 software is a complete load, system, energy, and economic analysis program. This building was zoned vertically because all three floor plans are practically identical. These zones were derived with the thought that each zone would have its own air handler. This will allow the mechanical system to condition the zones separately. This is important during the summer months when students will not be in the building. Having separate air handlers for each of these spaces will allow us to condition these public spaces while not wasting energy conditioning the classrooms when no students are present. Additionally the system is configured so that the community zone can run independently on emergency power, as this zone houses the multipurpose room that will act as a community shelter in the event of an emergency.

Table 1 shows a breakdown of peak building loads per each of our three zones. Additional Zone Loads that are broken down by load sources can be seen in Appendix pgs 16-17

Building Loads				
Zone		Cooling Capacity [TONS]	Heating Capacity [TONS]	Airflow [CFM]
1	Academic	86.7	64.2	35,610
2	Community	57.7	39.6	25,525
3	Pool	13.9	28.3	7,800
	TOTAL	158.3	132.1	68,935

Table 1: Building Peak Load Summary – Trane TRACE700 Outputs

In selecting the other equipment (i.e.: boilers, chillers, Cooling Tower, etc.) several energy analyses were done in determining the efficiency of our system configuration. It was determined based on the configuration that the system would recover and reuse enough energy to reduce our energy costs by up to 65% during the academic school year and roughly 50% year round. This allowed us to downsize our boilers by roughly 50% which is a great upfront cost savings. The chillers however were not able to be downsized as there was a minimal difference in the year round cooling capacities. It was selected that three chillers be used as to optimize the efficiency of the chiller configuration. Table 2 shows our Equipment breakdown with the respective capacities. See the Mechanical Room Layout in Appendix pg 18.

Equipment Loads	
Equipment	Capacity
Chiller-1	60 Tons
Chiller-2	60 Tons
Chiller-3	60 Tons
Cooling Tower	175 Tons
Boiler-1	800 MBh
Boiler-2	400 MBh
OAU-1	38,000 CFM
OAU-2	27,000 CFM
OAU-3	8,000 CFM
EAU-1	34,500 CFM
EAU-2	24,500 CFM
EAU-3	9,000 CFM

Table 2: Equipment Load Summary

3. Rationale for System Selection/Solutions:

3.1 HVAC & Heat Recovery

In order to develop the mechanical design for our building a baseline energy model was created using the Trane Trace700 modeling software. This model included all minimum values for occupancy density, construction types, and specific zone requirements. This model was also used to quantify the peak loads required by each space in the building as shown in Table 3. The airflow rates listed here have been calculated using the ASHRAE 62.1-2007 Minimum Ventilation equation. The airflow values reported in the Trace outputs were not high enough for ASHRAE standards and were certainly not 30% above the calculated ASHRAE airflow minimum, which is required to achieve LEED NC-2009 IEQ Credit 2: Increased Ventilation.

In following with these design criteria, it was decided that a 100% outdoor air system be implemented. This is great for an academic environment as it has been shown that larger percentages of outdoor air ventilation facilitates better performance by students and teachers. It has even been shown to increase test scores of the students in some studies. We felt that this aspect of our design was very important as the students of Reading need to have an environment that will help them learn and be conducive to success. As this is a region with socioeconomic challenges, we feel that these academic environments should be as accommodating as possible. In designing the system in this manner we were able to decrease the duct sizes and required cfm for each space. This too allows for us to supply 30% more outdoor air than is required by the

Zone		Cooling Capacity [TONS]	Heating Capacity [TONS]	Airflow [CFM]
1	Pool	15.6	26.3	7800
2	Multi-Purpose Room	16.6	7.6	6225
3	Lobby/Admin Wing	41.7	33.0	19300
4	Central Wing	64.3	71.1	27300
5	Right Wing	19.6	10.8	8310
TOTAL		157.8	148.7	68935

Table 3: ASHRAE Baseline Peak Loads from Trane TRACE700 Model

ASHRAE baseline minimum. The 30% increase in ventilation rates will also earn a LEED Credit for the improved overall interior environment.

It too was decided to utilize round duct work as it easier to manufacture and install. By utilizing round duct as well we are able to expose the ductwork in the majority of the building which follows the Team Nexus goal of creating the building as a learning tool (as is seen in Figure 11).



Figure 11: Teacher classroom perspective

Heat Recovery:

In our schematic design phase a hybrid geothermal system was also considered. This system has been utilized in many school projects and has been used in some new projects in the Reading area. The reasons we veered away from using this system are as follows: Constructability, Cost, Project Exhaust Requirements, Flexibility, and Energy Efficiency.

In terms of constructability the hybrid geothermal system required a lot of front ended schedule time. The required well field (as shown below) would have taken up the vast majority of the existing field area on site and would have caused complications with the construction phasing.

Additionally, the system requires a very high upfront cost for digging the numerous wells and piping the heat transfer fluid throughout them. We felt as though this money could be better spent on enhancing the actual experience and other systems within the school. Being an area with so many socioeconomic factors, Nexus has continually taken every endeavor to ensure that the money is well spent to minimize the financial burden it would create to the community.

It was also determined that the inclusion of the pool would require special mechanical considerations. There are going to be many exhausting issues due to the chemicals that are absorbed into the exhaust air via evaporation from the pool. The geothermal system would not be able to help in conditioning this space as it only preheats air with the 55 degree solution being brought from the ground temperature. The pool will be constantly a heated zone due to the high load requirements of the pool and indoor air quality. It was found that this zone will very seldom, if ever; receive cooling except for dehumidification purposes. The exhaust from this area too is very corrosive and would require other considerations be taken into account with the piping for the hybrid geothermal.

In continuing with the pool, the system for this project needs to have the flexibility required to add zones to it as the pool is being specified as an alternate to the owner. If the pool is added onto the system, more wells would need to be created to accommodate the large loads and more extensive construction would need to be done to incorporate it into the system. This differs greatly with the Ethylene- Glycol runaround system as the pool can be added directly into the system by adding it to the runaround loop piping.

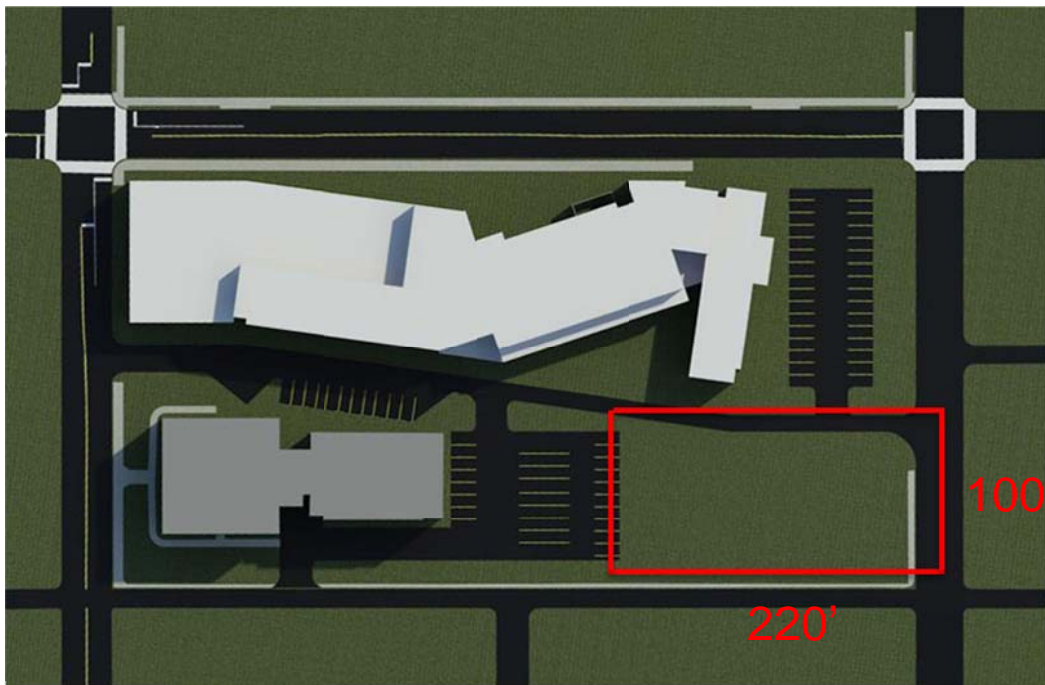

Figure 12: Geothermal Well Site for the approximate 48 wells needed based on building load profile

Lastly, the reason we went with the Ethylene-Glycol Recovery System was for its energy efficiency that greatly out performed that of the hybrid-geothermal. Hybrid geothermal systems have an efficiency of about 40-60%. It was determined however that with the implementation of the pool, it would only be possible to achieve the lower end of that spectrum in terms of energy recovery (mainly because of the pool for reasons mentioned earlier). The use of the Ethylene Glycol system allows for energy recovery of 60-90%.

In terms of constructability and maintenance the system has a very low initial cost in comparison to other forms of heat recovery. In comparison to typical heat recovery (i.e. enthalpy wheels and flat plate heat exchangers) this system is about 30% more expensive. Although this is a considerable amount, in comparison with other projects similar in size, the payback period for the system has been about three years. In the grand scheme of the overall building's lifecycle this is almost nothing. In terms of initial costs we too were able to downsize the boiler for the system to 50% of the building peak load. For constructability considerations there will be no impact to the current schedule as is designed. The Konvekta coil will take about 12 weeks to manufacture that will be specifically catered to the needs of each individual air handling unit. These coils will then be sent to the air handling manufacturer and will be installed in the units in about 10 weeks. This overall 22 week schedule works well with that on our construction process as it takes about 30 weeks for the roofs to be ready to place the units. Konvekta too will have an engineer on site at the first system start up and during installation to ensure that the contractor takes every measure possible in preventing leaks and allowing the system to operate at its designed efficiency. This too will ensure that the owner receives the results that were promised in the overall guaranteed energy simulation.

3.2 Equipment Configuration

Chillers:

The chillers were selected based on the information attached in Appendix pg 18. It was decided to use 3 chillers based on our cooling load profiles calculated via Trane Trace. When breaking down these profiles by a month-month analysis it was shown that the building cooling loads differ by 3 conditioning seasons. Therefore, 1 chiller will run at full capacity for 4 months out of the year, two chillers will run at full capacity for 4 months out of the year, and all three will run at full capacity for the remaining 4. This will ensure that the chillers are constantly operating at their optimal capacity to ensure efficient use of this equipment.

Boilers:

Two boilers will be utilized as to account for the add-alternate of the pool. With that being said, due to the efficiency of the heat recovery system both of these units have been downsized by about 50% which not only saves on upfront costs but lifecycle as the system will require less energy in meeting a smaller load.

3.3 Space Specific Considerations

3.3.1 Experience

In the lobby, special consideration was taken into conditioning this 3 story atrium space. As such an integrated approach was taken to devise a vertical chase that fit within the structural system and allowed large ductwork to be run through the space as it continued to feed the rest of the building. As is visible in Figures 13 & 14. This chase is placed such that it does

not conflict with the structural bay configuration

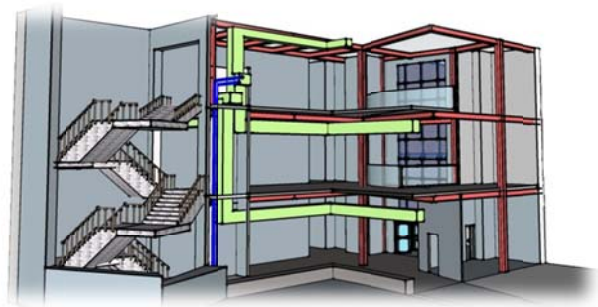

Figure 13: Sketch up Model of vertical chase in lobby

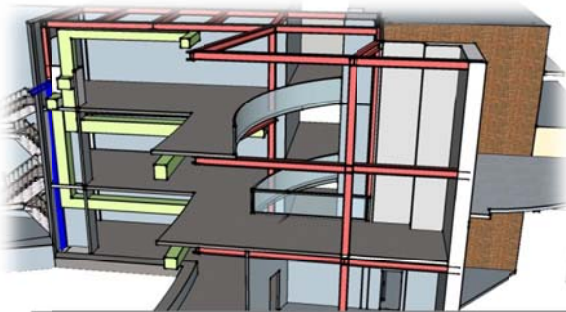

Figure 14: Sketch up Model of vertical chase in lobby

in any way.

3.3.2 Community

Special consideration was taken in the pool and gymnasium space in regard to air handler placement and duct sizing. Mechanical Engineers worked with the lighting and structural engineers to integrate the ducting layout such that it fit within the structural members and did not



Figure 15: Rendering of Pool Ceiling: Integration of Structure, Daylighting, & Ductwork

obstruct the skylights. This can be seen in Figure 15 & 16. It was also crucial that the ductwork in the pool run around the perimeter as to prevent condensation on the windows from the high humidity rates being expelled from the pool.

Additional consideration was taken into the exhausting layout which can be seen in Figure 17. In the ASHRAE publications from April 2012 (Natatorium Design), it was stated that the exhausting layout should be above the pool as to remove the evaporating trichloramine vapors as soon as possible. This will prevent occupant discomfort with things such as itchy eyes, itchy throat, etc.



Figure 16: Rendering of Multipurpose Room Ceiling: Integration of Structure & Ductwork

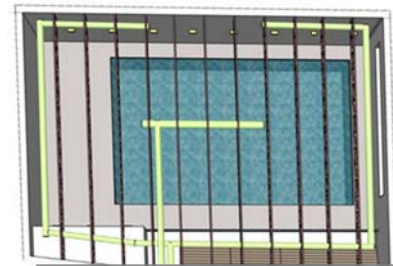

Figure 17: Sketchup Model Ducting Layout in Pool

3.3.3 Education

The education side proposed the most integration in having to utilize a lateral chase that runs along the hallway. This can be seen in Figure 18: These was a result of reducing structural members and construction cost thought the elimination of a second column line as discussed in the Team Nexus Paper. As is visible in Figure 18, round ductwork runs throughout this lateral chase and is actually exposed in the classroom in certain areas as round duct is more architecturally aesthetic than that of rectangular duct.

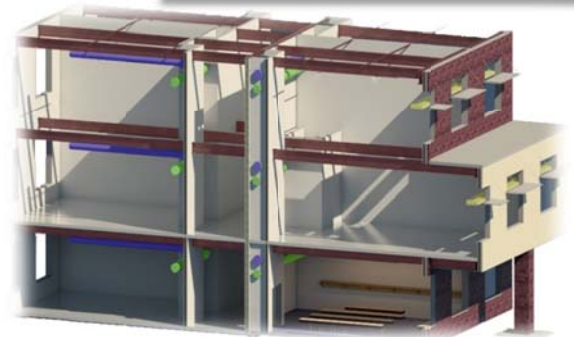

Figure 18: Ductwork running along hallway in the lateral chase.

3.4 Cost Analysis

3.4.1 First-Cost Comparison

Early in our design process, we narrowed our mechanical system design to two options: hybrid geothermal and an ethylene-glycol run around system. To make a decision between the two systems, we compared the up-front costs.

Hybrid Geothermal

A hybrid geothermal system is typically sized for the average building loads, which from the cooling load profile analysis we determined to be approximately 130 Tons. We sized the geothermal well field based on the rule of thumb that 250 feet of wells can produce 1 ton of cooling. With a bore depth of 500 feet, we would need approximately 48 wells.

In speaking with a Mechanical Contractor, we estimated that each well would cost approximately \$5000. This includes labor and materials. The installation of the well field would also take approximately 25 days. This would have impacted the construction schedule and site layout. The geotechnical report also stated that sink holes were possible in the well field site. This would have impacted constructability and possibly further elongate the schedule.

RS Means 2010 was used to get rudimentary pricing for equipment. The prices listed include labor and materials. For the hybrid geothermal system, heat pumps, a cooling tower, and a boiler would be necessary. There are roughly 50 rooms, so the average cooling load per room is approximately 2 tons. According to RS Means, a 2 ton water source heat pump (WSHP) is approximately \$2345. Larger heat pumps would be necessary for the gymnasium and the pool, approximately 15 tons each. A 15 ton WSHP costs approximately \$16,650. This breakdown can be shown in Table 3.

Equipment	Capacity	Unit Price	Quantity	Price
Geothermal Wells	130 Tons	\$ 5,000.00	48	\$ 240,000.00
WSHP-1	2 Tons	\$ 2,345.00	50	\$ 117,250.00
WSHP-2	15 Tons	\$ 16,650.00	2	\$ 33,300.00
Total				\$ 390,550.00

Table 3: ASHRAE Baseline Peak Loads from Trane TRACE700 Model

Ethylene-Glycol Run Around System

The addition of the ethylene-glycol heat exchange system (excluding piping) is \$295,000. This price is comprehensive. It includes the ethylene-glycol coils that will be delivered to the air handler manufacturer for installation, the hydronic unit which will be delivered directly to our job site, the entire control system, start-up and owner training, and performance monitoring during the first year of operation as well as a performance guarantee.

With the Konvekta system, there is no impact to the schedule. The packaged units will be delivered to the site. They must be ordered 5 months before they are scheduled to be delivered. This time frame includes the 3 months necessary for the Konvekta coil to be manufactured and installed.

Equipment	Capacity	Price
Ethylene-Glycol System	65,000 CFM	\$ 295,000.00

Table 4: ASHRAE Baseline Peak Loads from Trane TRACE700 Model

Conclusion

After a quick comparison, it is clear that the ethylene-glycol system has a lower first cost than the hybrid geothermal system, by almost \$100,000. The ethylene-glycol system also does not impact the construction schedule and will not delay the progress of other disciplines nor could it impact the opening of the building.

3.4.2 Total System Cost

In pricing all of the system components and specific units that we will be utilizing in the mechanical system for this project. A price tag of 990,935.00 was calculated should the system be implemented in conjunction with the pool. Should the pool not be included in the building scope the price will drop to \$863,210.00 which is a difference of nearly \$130,000. A full system summary and breakdown of this pricing calculation can be found on Appendix pg 18.

4. Concluding Summarization

In designing a system with the three spaces of Experience, Community, and Education in mind it was possible to create a mechanical system that meets all the needs of these unique spaces while providing an improved environment to the building's occupants. By reducing the building's loads through the integrated Nexus Façade system we were able to downsize equipment and save drastically on initial and long term energy costs. By recovering as much of the thermal energy that is leaving the building in some cases as much as 65% of the thermal energy is being retained. Lastly and most importantly through reusing this recovered energy with the use of the Ethylene Glycol system the design reduces annual energy costs by 50% from a typical baseline building. While keeping with the owner goals of safety, lifecycle and maintenance, and cost effectiveness, Nexus provides a valuable packaged product that is the overall design of the Reading Elementary School.

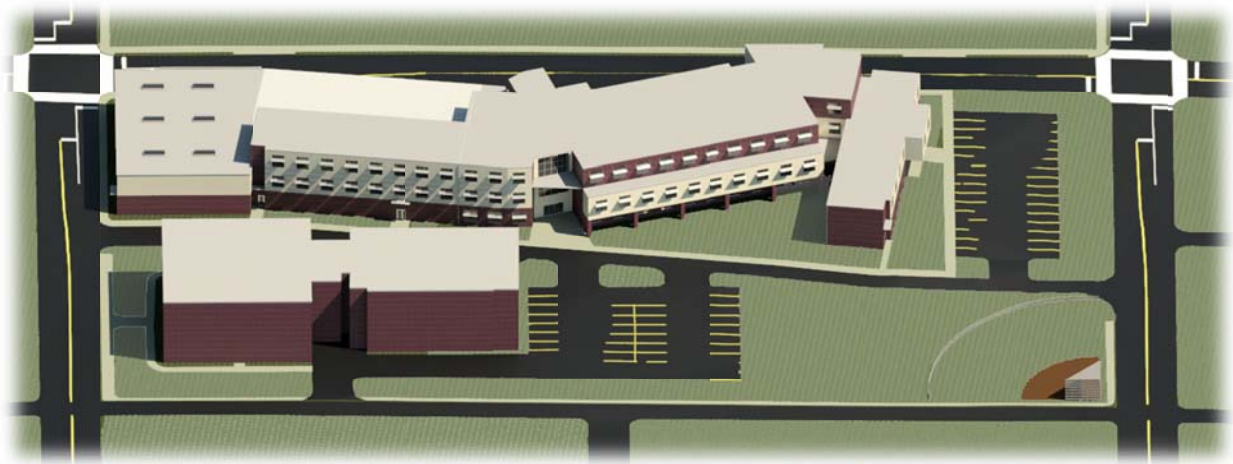

5. APPENDIX

5.1 LOAD PROFILES AND BREAKDOWNS

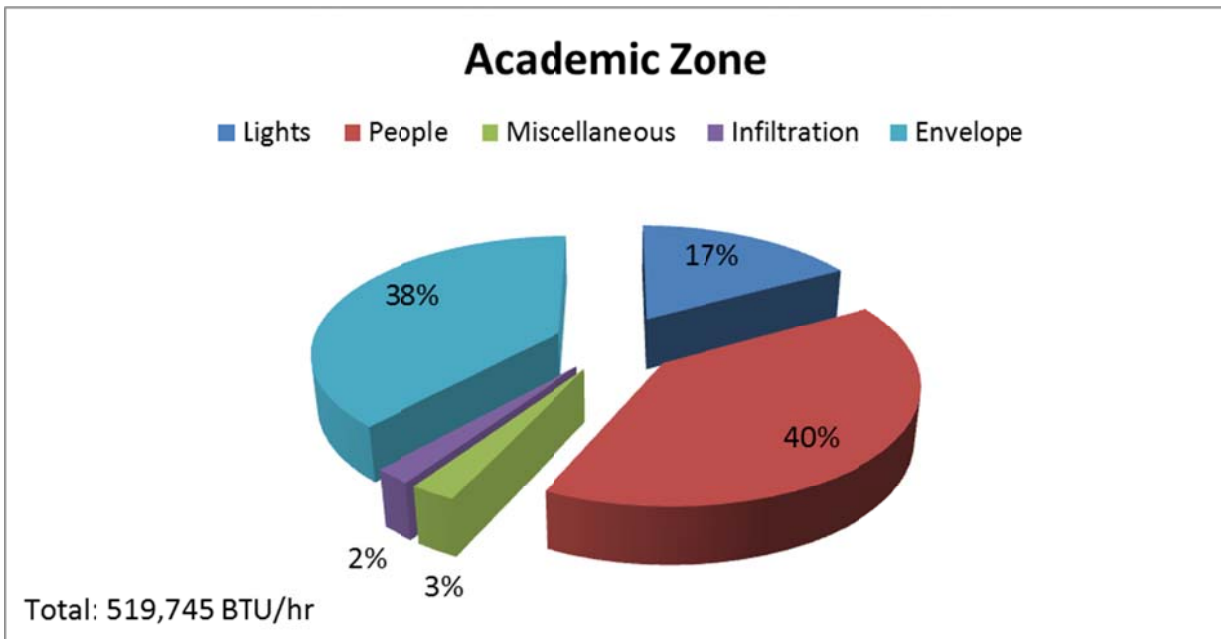
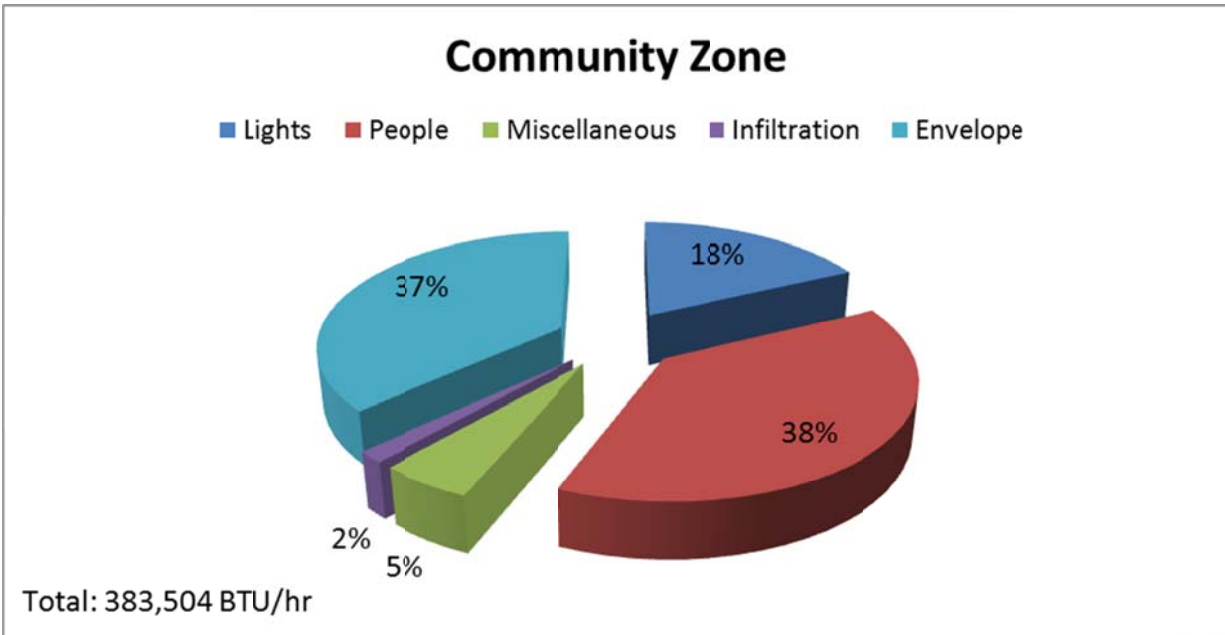

Pool Zone

■ Lights ■ People ■ Miscellaneous ■ Infiltration ■ Envelope ■ Skylite

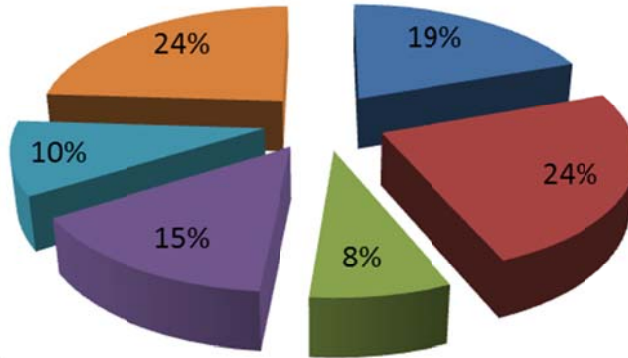

Total: 145,475 BTU/hr

Full Building Load Breakdown

■ Lights ■ People ■ Miscellaneous ■ Infiltration ■ Envelope

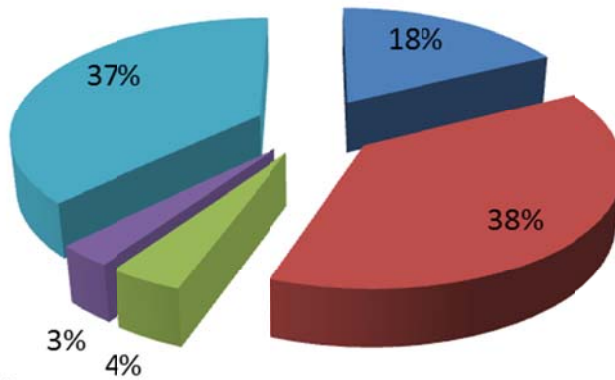

Total: 1,643,205 BTU/hr

5.2 Mechanical Room Layout

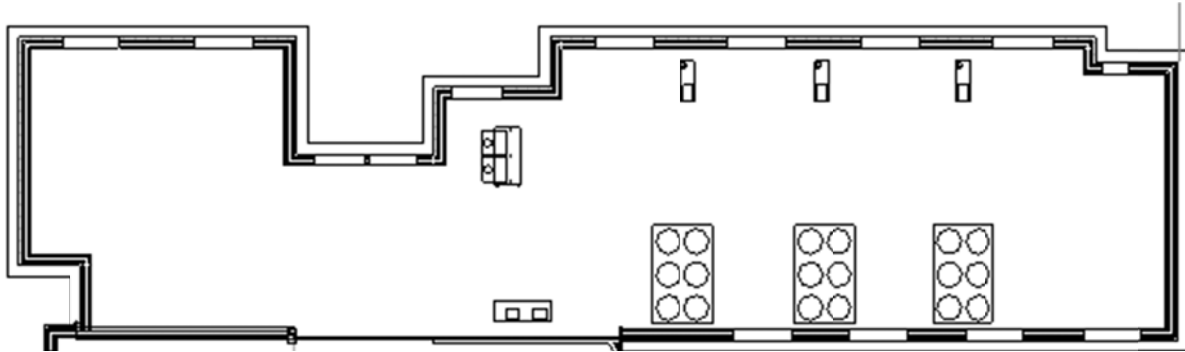

This mechanical room will be located in the Basement. There are three chillers placed 10 feet apart, 3 inline pumps across from the chillers. There are two boilers located in the upper left hand corner and the hydronic module for the ethylene glycol system located in the bottom right. This room will be accessible from the exterior of the building for maintenance purposes as well.

5.3 Equipment Cost Summary:

Equipment Breakdown			
Equipment	Description	Capacity	Price
Chiller-1	Rotary-Screw Water Chillers	60 Tons	\$ 55,300.00
Chiller-2	Rotary-Screw Water Chillers	60 Tons	\$ 55,300.00
Chiller-3	Rotary-Screw Water Chillers	60 Tons	\$ 55,300.00
Cooling Tower	Axial Fan, Induced Draft	175 Tons	\$ 27,375.00
Boiler-1	Gas-Fired Boiler	800 MBh	\$ 16,475.00
Boiler-2	Gas-Fired Boiler	350 MBh	\$ 7,725.00
OAU-1	Dedicated Outdoor Air	38,000 CFM	\$ 172,400.00
OAU-2	Dedicated Outdoor Air	27,000 CFM	\$ 163,200.00
OAU-3	Dedicated Outdoor Air	8,000 CFM	\$ 54,400.00
EAU-1	Exhaust Air Unit	34,500 CFM	\$ 12,320.00
EAU-2	Exhaust Air Unit	24,500 CFM	\$ 10,540.00
EAU-3	Exhaust Air Unit	9,000 CFM	\$ 5,600.00
Ethylene-Glycol System	Without Pool	65,000 CFM	\$ 295,000.00
Ethylene-Glycol System	With Pool	8,000 CFM	\$ 355,000.00
Total	Without Pool		\$ 863,210.00
Total	With Pool		\$ 990,935.00

5.4 Chiller Cooling Demand Profiles

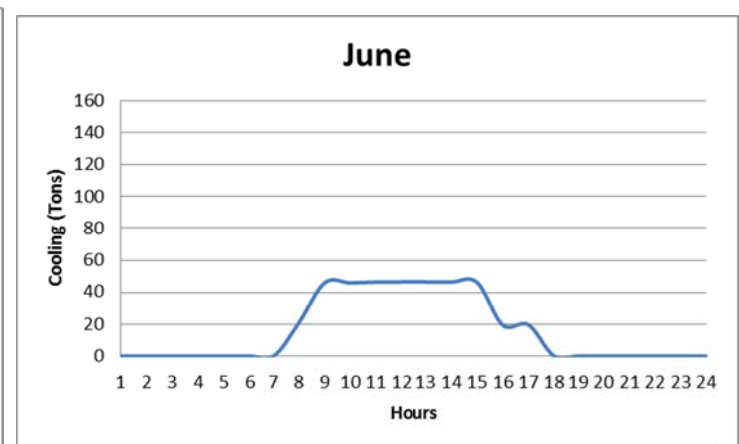
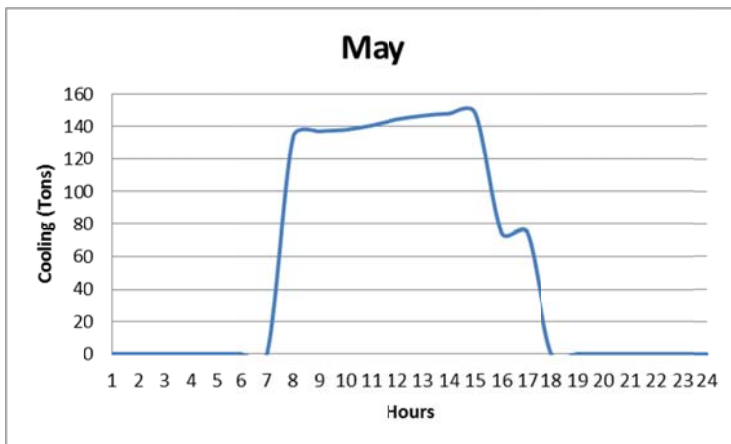
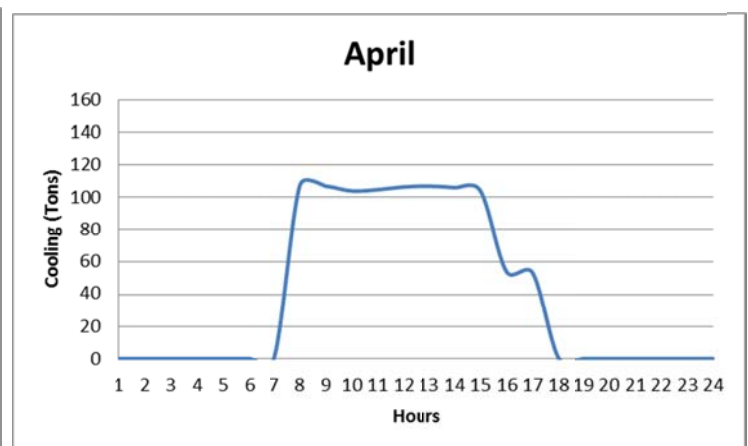
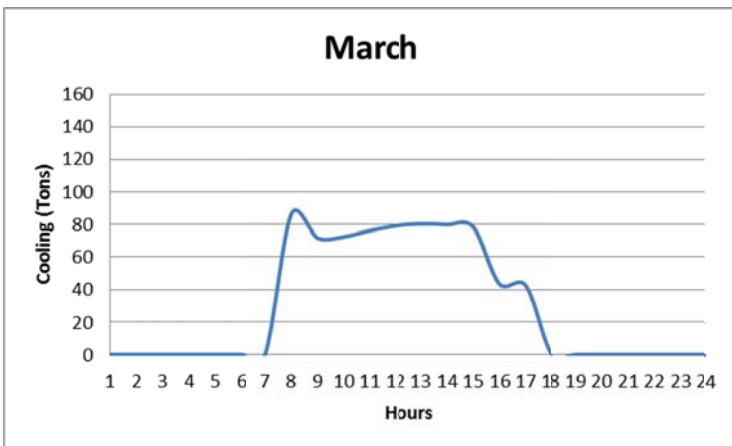
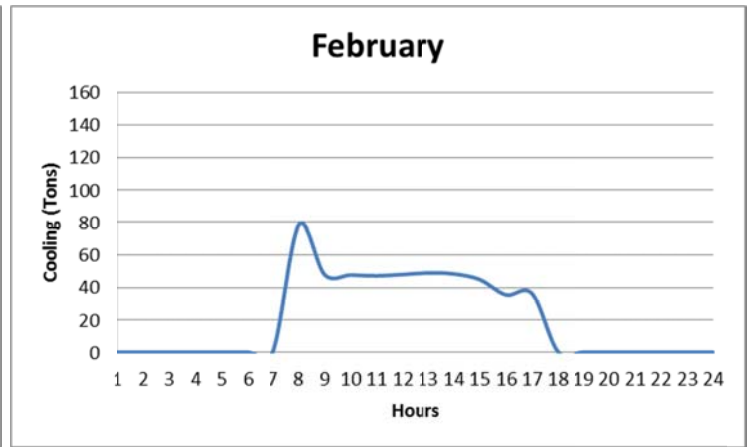
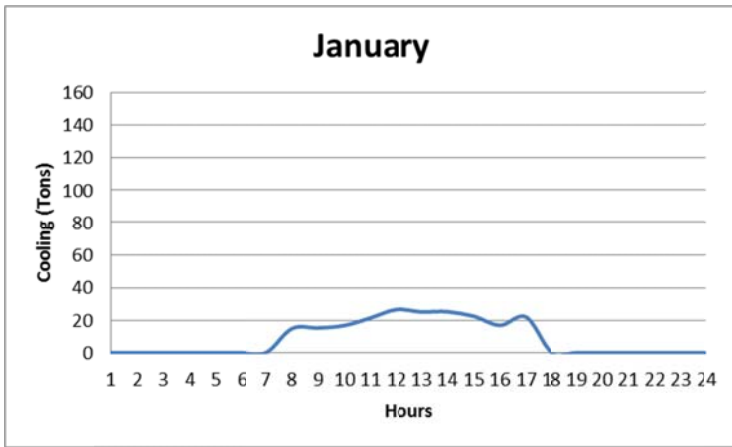

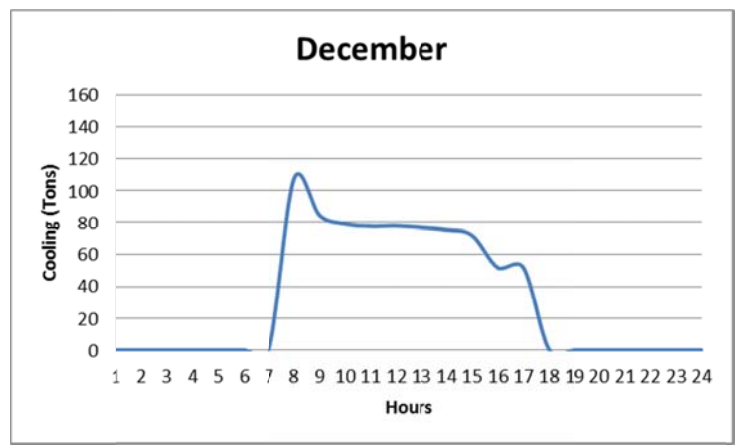
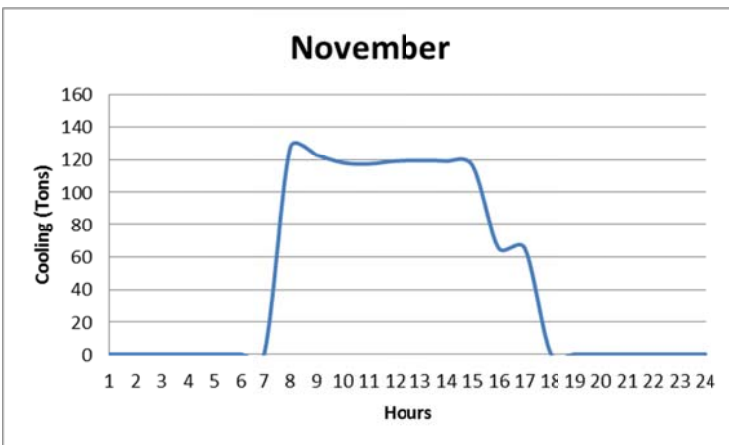
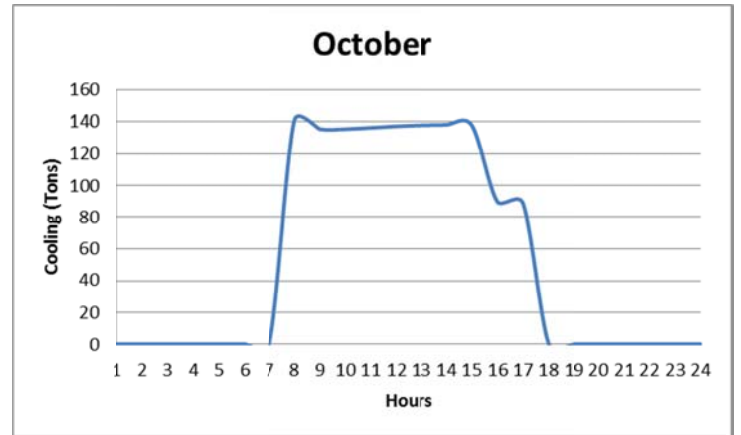
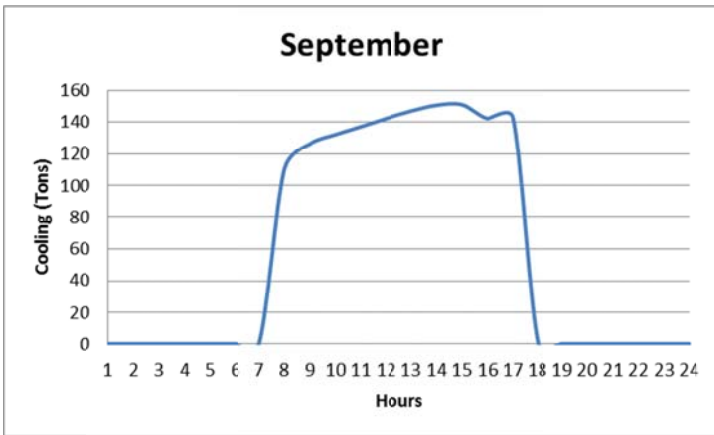
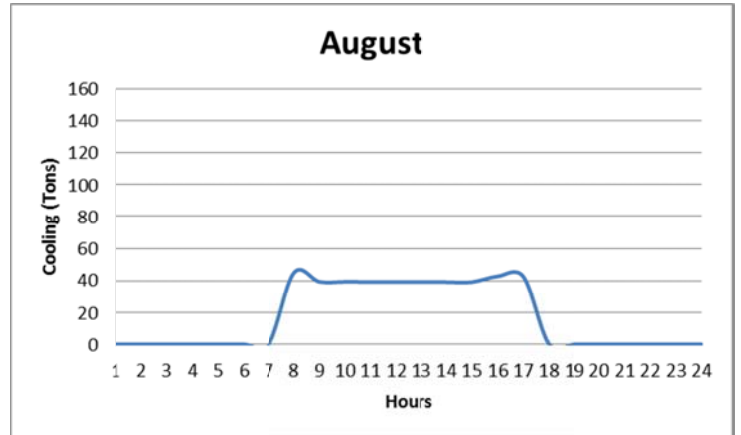
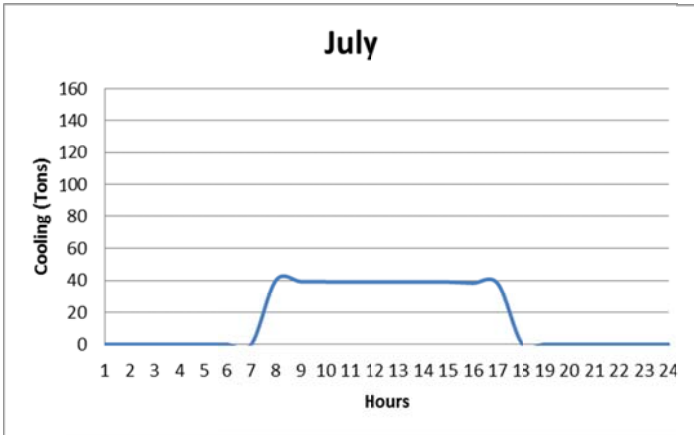

5.5 Chiller Plant Analysis

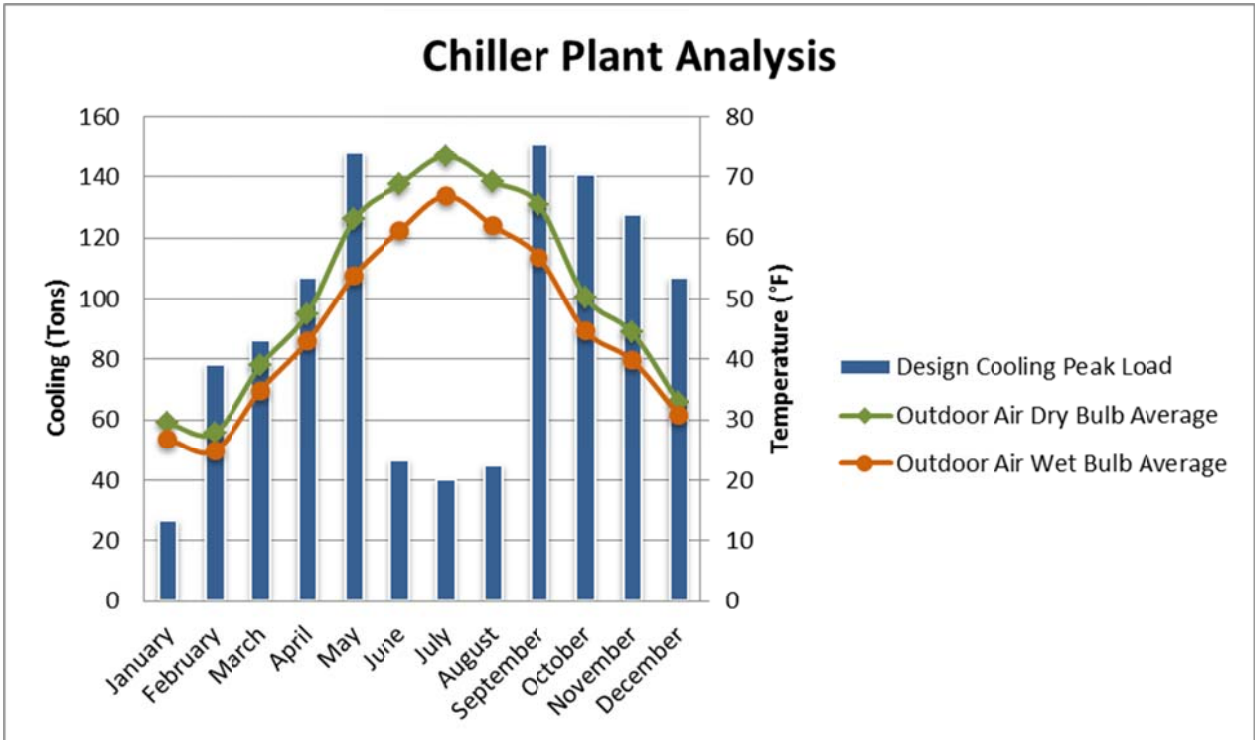

5.7 Technical Fin Data for Heat Exchanger:

	SHRC AHU 1	SHRC AHU 2	SHRC AHU 3
Quantity	2	2	1
Design			
type (fin spacing - mm)	3.0	3.0	3.0
height (inch)	49.4	41.5	47.4
length (inch)	145.7	126.0	70.9
installed depth (inch)	16.3	15.9	15.9
weight (dry) (lb)	2x 2249	2x 1632	1058
water capacity (gal)	2x 64.2	2x 45.5	30.6
corrosion protection	KO31	KO31	KO31
materials			
tubes	copper	copper	copper
fins (suitable for hp cleaning 2600 psi)	alu (0.0157inch)	alu (0.0157inch)	alu (0.0157inch)
collectors	steel	steel	steel
Rating data air side			
Media	AIR	AIR	AIR
volume flow (cfm)	2x 17627	2x 12760	7799
intake (°F/%r.h.)	30.0/ 65	30.0/ 65	30.0/ 65
outlet (°F/%r.h.)	64.9/ 17	64.9/ 17	64.9/ 17
pressure drop (inch H2O)	0.551	0.551	0.512
Rating data water side			
Media	ETH-GLY 30 %w	ETH-GLY 30 %w	ETH-GLY 30 %w
volume flow (gpm)	2x 48.11	2x 34.83	21.29
intake / outlet (°F)	71.6/ 41.6	71.6/ 41.6	71.6/ 41.6
pressure drop (ft H2O)	97	97	101
Performance (Btu/h)	2x 682508	2x 494128	301739

	EHRC EAHU 1	EHRC EAHU 2	EHRC EAHU 3
Quantity	2	2	1
Design			
type (fin spacing - mm)	3.0	3.0	3.0
height (inch)	45.5	41.5	47.4
length (inch)	135.8	126.0	70.9
installed depth (inch)	16.3	15.9	15.9
weight (dry) (lb)	2x 1940	2x 1632	1058
water capacity (gal)	2x 55.6	2x 45.5	30.6
corrosion protection	KO32	KO31	KO31
materials			
tubes	copper	copper	copper
fins (suitable for hp cleaning 2600 psi)	alu coated (0.4)	alu (0.0157inch)	alu (0.0157inch)
collectors	steel	steel	steel
Rating data air side			
Media	AIR	AIR	AIR
volume flow (cfm)	2x 14997	2x 12760	7999
intake (°F/%r.h.)	75.0/ 60	75.0/ 60	75.0/ 60
outlet (°F/%r.h.)	52.5/ 96	52.3/ 96	52.4/ 96
pressure drop (inch H2O)	0.669	0.669	0.669
Rating data water side			
Media	ETH-GLY 30 %w	ETH-GLY 30 %w	ETH-GLY 30 %w
volume flow (gpm)	2x 44.20	2x 37.60	23.58
intake / outlet (°F)	41.4/ 71.5	41.4/ 71.8	41.4/ 71.6
pressure drop (ft H2O)	92	92	89
Performance (Btu/h)	2x 627702	2x 539711	336822

5.8 Ethylene Glycol Energy Comparisons

Energy/Financial Comparison: Pennsylvania State AEI

OAU-1/2, EAHU-1/2

		Without E Recovery	Konvekta System
SUMMARY			
Winter			
Heating Energy Requirement	kWh/a	856,050	402,000
Effectiveness Heating			0.53
Summer			
Cooling Energy Requirement	kWh/a	194,610	178,410
Effectiveness Cooling/Reheat			0.08
Year			
Heating Energy	kWh/a	856,050	402,000
Cooling Energy	kWh/a	194,610	178,410
Electricity (Δ Fans, Pumps)	kWh/a	0	14,503
Total Energy Consumption	kWh/a	1,050,660	594,913
Effectiveness			43%
Peak Demand			
Cooling	kW	1,525	1,355
	tons	433	385
Heat	kW	1,340	535
	MBTU/h	4,572	1,825

Energy/Financial Comparison: Pennsylvania State AEI

OAU-1/2/3, EAHU-1/2/3

		Without E Recovery	Konvekta System
SUMMARY			
Winter			
Heating Energy Requirement	kWh/a	965,900	407,500
Effectiveness Heating			0.58
Summer			
Cooling Energy Requirement	kWh/a	219,660	200,460
Effectiveness Cooling/Reheat			0.09
Year			
Heating Energy	kWh/a	965,900	407,500
Cooling Energy	kWh/a	219,660	200,460
Electricity (Δ Fans, Pumps)	kWh/a	0	16,514
Total Energy Consumption	kWh/a	1,185,560	624,474
Effectiveness			47%
Peak Demand			
Cooling	kW	1,722	1,522
	tons	489	432
Heat	kW	1,512	411
	MBTU/h	5,159	1,402

5.9 MSDS Report



Health	1
Fire	1
Reactivity	0
Personal Protection	C

Material Safety Data Sheet
Ethylene glycol MSDS

Section 1: Chemical Product and Company Identification

<p>Product Name: Ethylene glycol</p> <p>Catalog Codes: SLE1072</p> <p>CAS#: 107-21-1</p> <p>RTECS: KW2975000</p> <p>TSCA: TSCA 8(b) inventory: Ethylene glycol</p> <p>CI#: Not available.</p> <p>Synonym: 1,2-Dihydroxyethane; 1,2-Ethandiol; 1,2-Ethandiol; Ethylene dihydrate; Glycol alcohol; Monoethylene glycol; Tescol</p> <p>Chemical Name: Ethylene Glycol</p> <p>Chemical Formula: HOCH₂CH₂OH</p>	<p>Contact Information:</p> <p>Sciencelab.com, Inc. 14025 Smith Rd. Houston, Texas 77396</p> <p>US Sales: 1-800-901-7247 International Sales: 1-281-441-4400</p> <p>Order Online: ScienceLab.com</p> <p>CHEMTREC (24HR Emergency Telephone), call: 1-800-424-9300</p> <p>International CHEMTREC, call: 1-703-527-3887</p> <p>For non-emergency assistance, call: 1-281-441-4400</p>
---	---

Section 2: Composition and Information on Ingredients

Composition:

Name	CAS #	% by Weight
Ethylene glycol	107-21-1	100

Toxicological Data on Ingredients: Ethylene glycol: ORAL (LD50): Acute: 4700 mg/kg [Rat]. 5500 mg/kg [Mouse]. 6610 mg/kg [Guinea pig]. VAPOR (LC50): Acute: >200 mg/m 4 hours [Rat].

Section 3: Hazards Identification

Potential Acute Health Effects:
Hazardous in case of ingestion. Slightly hazardous in case of skin contact (irritant, permeator), of eye contact (irritant), of inhalation. Severe over-exposure can result in death.

Potential Chronic Health Effects:
CARCINOGENIC EFFECTS: A4 (Not classifiable for human or animal.) by ACGIH. MUTAGENIC EFFECTS: Mutagenic for mammalian somatic cells. Non-mutagenic for bacteria and/or yeast. TERATOGENIC EFFECTS: Not available. DEVELOPMENTAL TOXICITY: Not available. The substance may be toxic to kidneys, liver, central nervous system (CNS). Repeated or prolonged exposure to the substance can produce target organs damage. Repeated exposure to a highly toxic material may produce general deterioration of health by an accumulation in one or many human organs.

Section 4: First Aid Measures

5.10 Economic Summary- Trane TRACE700

Economic Summary

Project Information

Location: Reading, PA
 Project Name: Elementary School
 User:
 Company:
 Comments:

Study Life: 20 years
 Cost of Capital: 10 %
 Alternative 1: Reading Elementary School

Economic Comparison of Alternatives

Yearly Savings (\$)	First Cost Difference (\$)	Cumulative Cash Flow Difference (\$)	Simple Payback (yrs.)	Net Present Value (\$)	Life Cycle Payback (yrs.)	Internal Rate of Return (%)	Life Cycle Cost
---------------------	----------------------------	--------------------------------------	-----------------------	------------------------	---------------------------	-----------------------------	-----------------

Annual Operating Costs

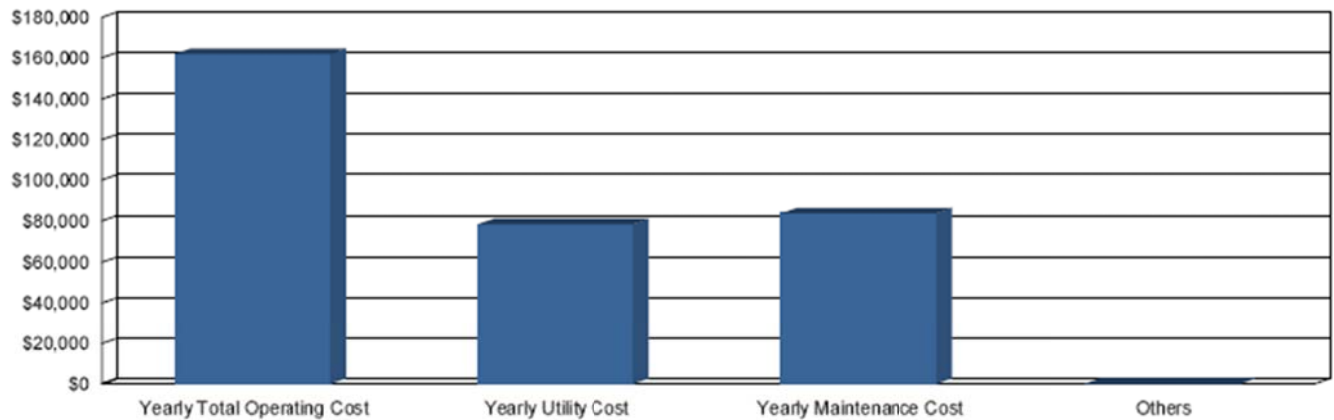

■ Alt 1

Yearly Total Operating Cost (\$)	Yearly Utility Cost (\$)	Yearly Maintenance Cost (\$)	Plant kWh/ton-hr
----------------------------------	--------------------------	------------------------------	------------------

Monthly Utility Costs

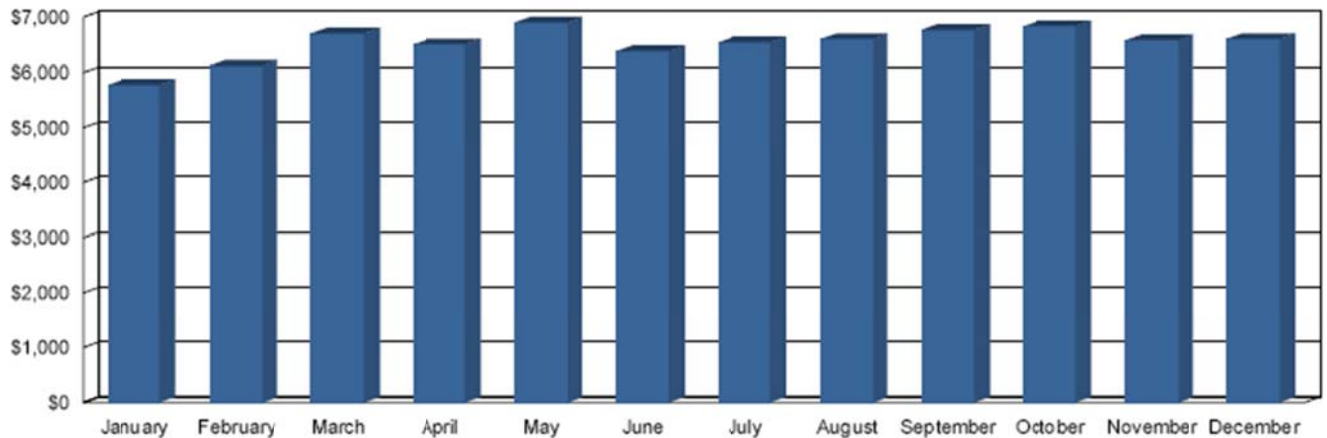

■ Alt 1