

Milton S. Hershey Medical Center Biomedical Research Building
Hershey, Pennsylvania

Joshua Zolko, Structural Option
15 January 2014

Table of Contents

Executive Summary	3
Building Introduction	3
Systems	4
Foundation System	4
General Floor Framing	4
Floor System	5
Expansion Joints	6
Roof System	6
Secondary Structural System for Mechanical Equipment	6
Support of Curtain Walls	7
Support of Architectural Cylinder on Corner of Building	7
Lateral System	7
Overall Interaction of Systems	8
Design Codes	8
Typical Materials Used	8
Gravity Loads	8
Lateral Loads	9
RAM Model	9
Torsion	10
Stiffness, Relative Stiffness and Load Distribution	10
Drift	12
Overturning	13
Spot Check	13
Conclusion	14
Appendix	16
Elevations	17
Plans	18
Foundation	18
First Floor	19
Second Floor	20
Typical 3rd through 7th Floor Plans	21
Calculations	22
Seismic Calculations	22
Wind Calculations	26
Initial Spot Checks	28
Wind Load Case Tables	37
Eccentricity Calculations	40
Spot Checks	41

Executive Summary

A thorough and exhaustive analysis was conducted on the Milton S. Hershey Medical Center Biomedical Research Building. A RAM model was created, while attempting to adhere as close to the original building, in both floor area and mass, as possible for the most accurate results. To supplement the model, it was found that the maximum eccentricity was at 9", due to slight irregularity in the column layout. This eccentricity only exists along the short axis of the building. Torsion was allowed to be neglected, as it was negligible, and this is supported by the model output file.

An overturning analysis was conducted, and it was found that overturning from seismic forces controlled along the long axis of the building, and wind controlled along the short axis of the building. Both sets of forces were significantly less than the resisting moment from the weight of the building. Shear forces that acted upon the building were from the 4 wind load cases listed in ASCE 7-05, and it was determined that wind load case 1 controlled overall for wind loads, 855 kips at the lowest floor along the short axis, 233 kips seismic controlled along the long axis of the building.

Stiffness was found for the columns of the building. It was assumed that relative stiffness would not change along either axis and a stiffness check performed in the RAM model through the application of a 1kip load in both directions validated this assumption. It was found that each column resists about 1.5% of the shear force at any given floor. A spot check under the worst case scenario was done to validate the findings from the RAM model, using the 1.5% force distribution, and it was found that lateral forces only take at most 35% of the moment capacity of a column. This, through interaction, allows 65% capacity for axial load, and it was shown that about 30% total capacity was utilized for axial, allowing for 35% redundancy, for Lack of significant torsional effects greatly simplified analysis of the building. Finally, total building drift, and story drift was also analyzed and found to be well under H/400, and 2% seismic requirements.

Using the results from the analysis of the existing building as reference, a redesign of the building will be investigated. Adding 3 additional stories to the building, of which, the top story will be doubled, will be the focus of the redesign. Structurally, lateral, foundation, and support systems will have to be verified, designed and resigned as need be for the weight of these stories. Lighting, electrical, HVAC, will have to be taken into account for the additional space, and considering the rec space/studio of the top story, acoustical management will also need to be resolved. Cost approximations will also be done for the entirety of the addition.

Building Summary

The Milton S. Hershey Medical Center Biomedical Research Building in Hershey, Pennsylvania, is an education and research facility. It is owned by the Milton S. Hershey Medical Center, and is part of Penn State Hershey, and thus is a branch campus of Pennsylvania State University. It is a 110' tall structure with 7 stories and 245000 total square feet of floor space. It was constructed by Alexander Building and Shoemaker Construction Companies and managed by Alvin H. Butz, Inc. between 1991 and 1993, costing \$49 million. It was designed by Geddes Brecher Qualls Cunningham, and engineered by The Sigel Group and Earl Walls Associates. The most distinguishing architectural aspect of the building is a large cylinder that extends from the 2nd floor up to the roof on one of the corners of the building.

Foundation System

The Biomedical Research Building at Penn State Hershey utilizes a simple monolithic concrete structure to serve its load distribution needs. This structure stands on a series of large, 3 to 7 and a half foot diameter caissons which loads ranging from 250 kips to 1610 kips, with most loads around 1000 kips expected by the building's original engineers. These caissons have a 40 kip per square foot requirement, using 3000 psi 28 day strength concrete, and are set into the bedrock below. It should be noted that even though 3000 psi concrete was called for, there was an instance where 1000 psi concrete was called for in the plans. A variety of different sized 60ksi steel rebar are utilized in reinforcing both the caissons and the grade beams, with clear cover at 2.5 inches, given its exposure to ground.

Caissons were chosen as the building's foundation, as the area is known to have large sink holes develop within the limestone deposits. This prevents future sinkhole development underneath or nearby to have any drastic effect on the Biomedical Research Building's safety, especially as sinkholes are not usually detected until it is too late. As seen in figure 2, grade beams act to transfer forces from the columns into the caissons when columns and caissons do not line up, and to further the idea of sink hole damage prevention, using beams varying from 14 inches wide by 30 inches deep to 7 feet by 16 foot 8 inches deep.

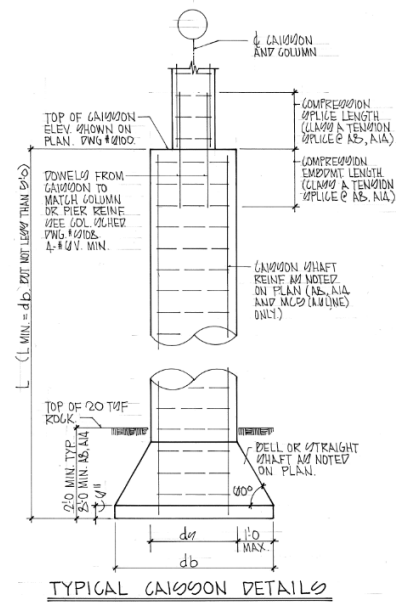

Figure 1. Typical Caisson Detail

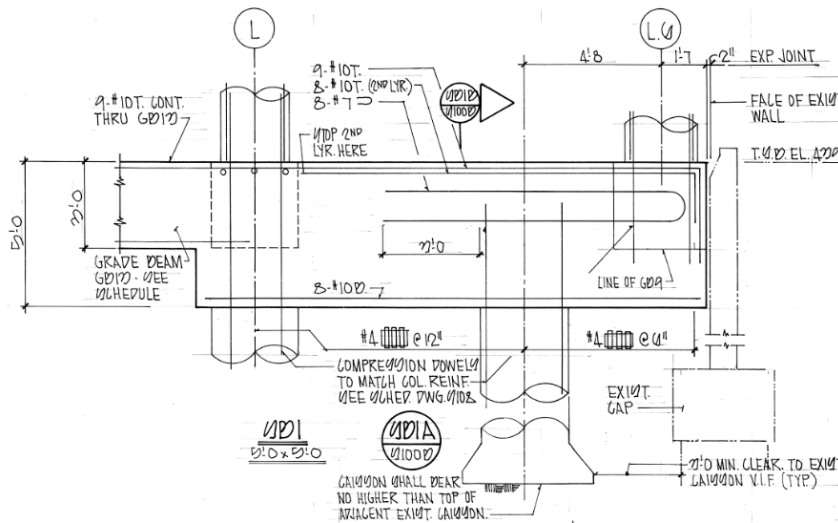

Figure 2. Example of caisson and column misalignment

General Floor Framing

Floors of the Biomedical Research building are supported by large beams typically spanning 20' that predominately go in the longitudinal direction of the building for the central part, and in the far ends of the building. These beams vary from 12 to 36 inches deep, and 3 to 8 feet wide. There obviously were some depth restrictions where the 8 foot wide beams are located. Shown in Figure 3 on the next page, the building is effectively cut into 3 sections by two set of three openings in the floors, with columns and beams on all sides of these openings. These openings are to serve the building in its HVAC, plumbing and electrical needs. Additional openings in the floor are directly adjacent to these service openings, for elevator shafts that serve the entirety of the building. These elevator shafts have two additional columns to help support the concentrated load of the elevator and its machinery, distributing the load around the openings.

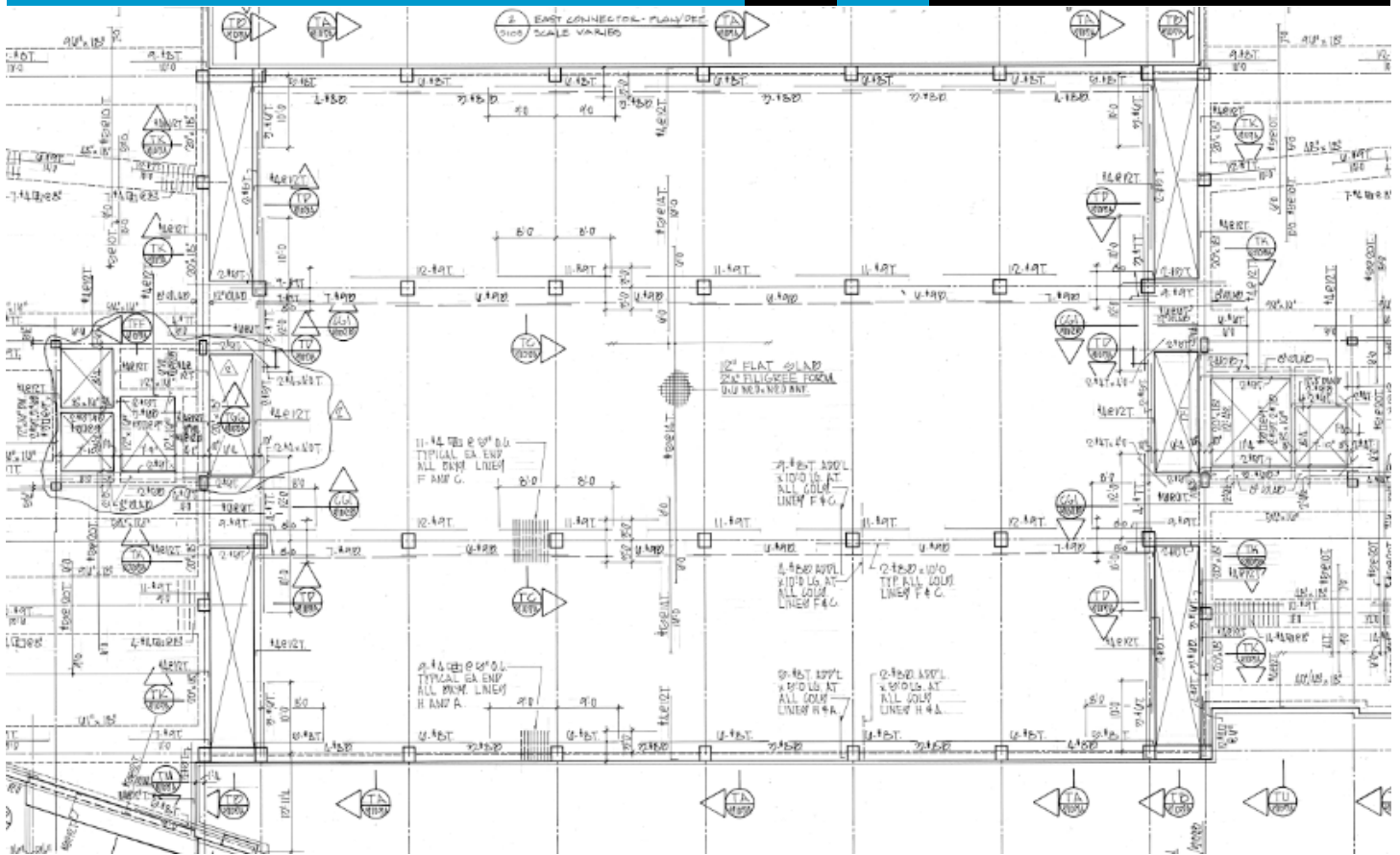

Figure 3. Typical Floor Plan - The three vertical openings on each side are for HVAC, electrical, and mechanical usage, and the openings just to the outside of these openings are elevator shafts.

Beams use rebar at the top and bottom of the beam to resist positive and negative moments, and such reinforcement is usually discontinued at some point after development length has been achieved. Shear reinforcement is used in the form of stirrups, using #3 or #4 sized rebar with 40ksi steel. There are no drop panels used, and as found in the calculations on page 30 in the Appendix, the building would benefit from drop panels.

Supporting the beams are a multitude of columns, averaging about 2 feet by 2 feet in dimension. Circular columns are also used, and average about 30 inches in diameter. 60ksi rebar are used to reinforce the columns, with varied sizes and number of rebar utilized. Clear cover for the columns and beams inside of the building is at 1.5 inches.

Floor Systems

On these beams are a system of one way slabs designed to support 100 to 125 psf floor loads, using 4000 psi 28 day strength concrete, with temperature reinforcement and a 6x6 W2.0xW2.0 WWF. The one way slabs are oriented perpendicular to the beams, and are treated as beams in that direction. On the ground level, where large mechanical equipment is located, slabs are thickened according to the size and weight of the machinery, as applicable.

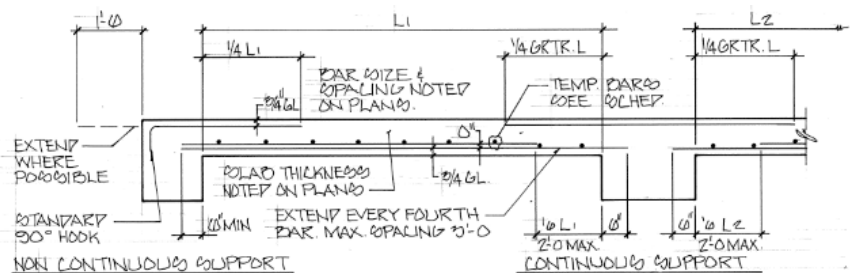

Figure 4. Typical Slab Detail

Expansion joints

There are no expansion joints, but there is temperature reinforcement to handle the stresses of expansion and contraction of the building. In addition, there are also control joints that are designed to mitigate and control potential cracking in the building, which would include crack development due to temperature change. A typical control joint detail is shown below.

TEMPERATURE BARS	
SLAB THK.	REINF.
4" LESS THAN 12"	#3 @ 12"
5" " 16"	#4 @ 18"
6" " 20"	#4 @ 18"
7" " 24"	#4 @ 18"
8" " 28"	#4 @ 18"
9" " 32"	#4 @ 18"

Figure 5. Temperature Reinforcement Schedule

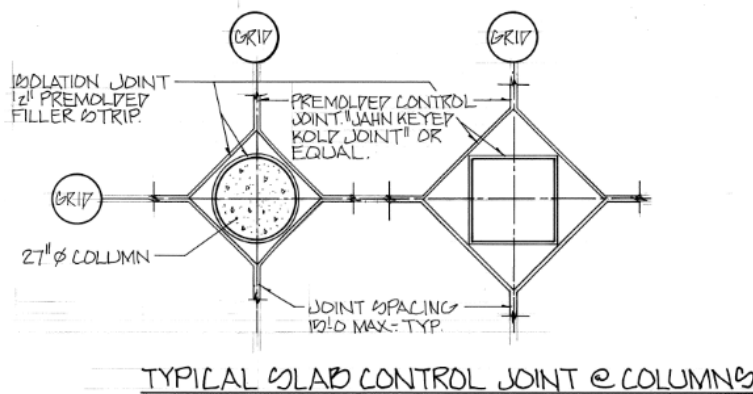

Figure 6. Typical Control Joint Detail

Roof system

Elevator machinery and miscellaneous other HVAC machinery is stationed on the roof, as typical. These must be supported in addition to snow loads, and were designed also to manage rain water, diverting it to drainage pipes on the roof. There are parapets of varying heights also located on the roof, preventing water run off on the sides of the building. The 8 inch thick roof is sloped slightly to aid in rain water management, preventing it from pooling, and potentially causing a collapse. Calculations on page # in Appendix # for snow loads show that the design load of 30 psf is in excess of the 21 psf snow load that would accumulate on the roof should snow drifts come into play during winter months.

Secondary Structural System for Mechanical Equipment

As mentioned before, for the ground level, slabs are thickened for the additional weight, and elevator equipment has its own columns around the elevator shaft to handle both the weight of the machinery, the elevator carriage, and the people that may be using the elevator at any given time.

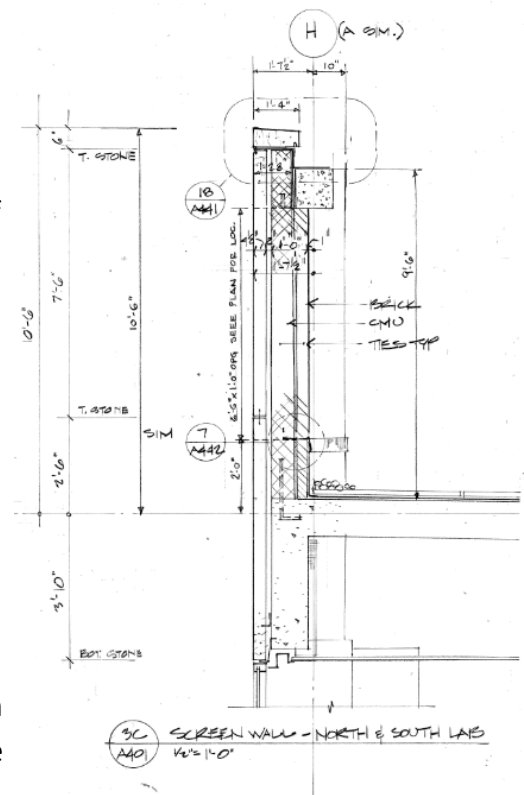

Figure 7. Example Section of a Parapet.

Support of Curtain Walls

Curtain walls and cladding for this building consist of limestone, granite and glass panels. These are often anchored directly into the concrete structure where they are applied. Two inches of clearing between the panel and the building are in place to insure that moisture has a way to weep and not accumulate behind the panel. Slabs have beams or some other support at the edge of their spans of varying depths and widths to support additional weight where panels are installed.

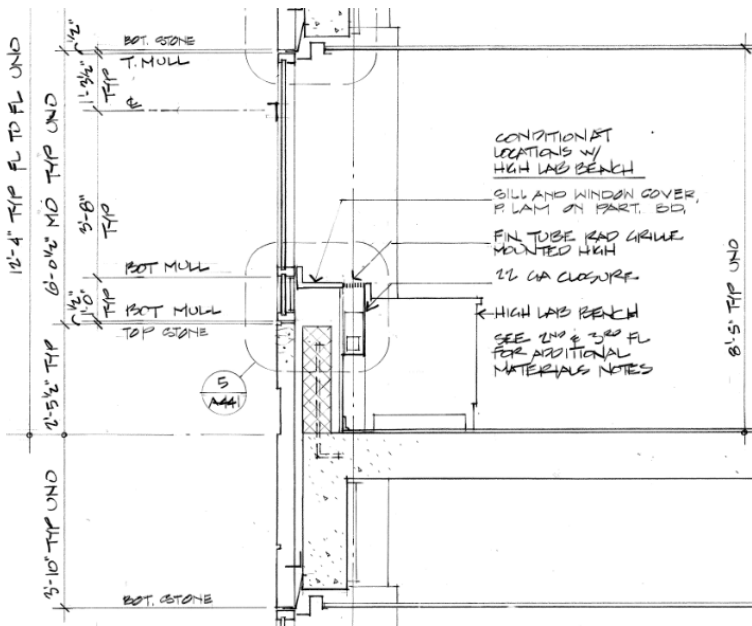

Figure 8. Example Section of Curtain Wall

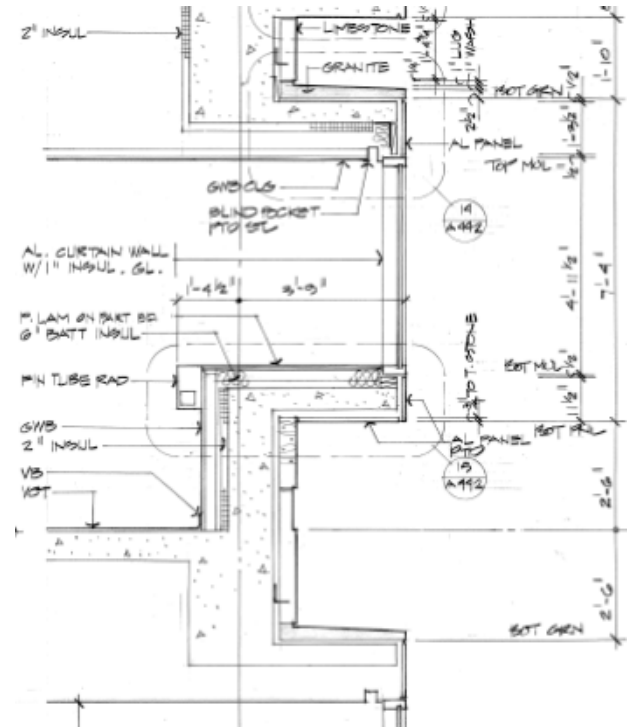

Figure 9. Example Section of Exterior Cladding

Support of Architectural Cylinder on Corner of Building

There is an architectural cylinder on the corner of the building that is supported by 4 - 33" by 33" columns reinforced with 8 #11's as in Figure 10. The column is 125% larger than the columns above it, possibly from a safety standpoint. From the 2nd floor to the roof, the slabs on the interior support its glass, granite and limestone facade, and on the other face, a solid wall supports additional aesthetic wall panels along the stairwell, as seen in a section in Figure 11.

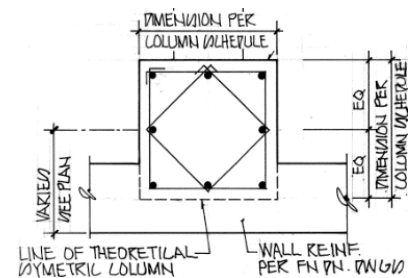

Figure 10. Illustration of Column Used for Support of Architectural Cylinder

Lateral system

Wind plays a large factor in the surrounding buildings, especially the Crescent, the main hospital building of the Hershey Medical Center. Its long and unique shape plays a direct role in sheltering the Bio-medical Research Building from direct wind, as well as other surrounding buildings in the area. As for the Bio-medical Research building, it has an oblong shape, making wind forces to be manageable in one direction by a smaller area for wind to push up, and a large structure to resist this wind load, but leaves a larger area to resist a larger wind load. Wind forces are directly resisted by the curtain on the building, and

forces are then transferred to the 8"-12" thick concrete slabs. Slabs then transfer the load into the columns and shear walls, and eventually down into the ground, through the caissons. For the short side of the building, there are large concrete beams that would play a strong role in resist wind forces.

Overall Interaction of Systems

Ultimately, all existing systems rely heavily on the largely straightforward concrete structure, with lateral forces, going through the curtain walls, and most live and gravity loads behind handled by the floor slabs. The one way slabs transfer the loads to the beams and shear walls, and subsequently into various columns, which also support equipment loads and resulting roof loads. Excessive cracking in the slabs are controlled by control joints, temperature reinforcement maintains the effectiveness of the slabs under various temperature related stresses. Large grade beams then take the loads from the columns, as well as the thickened ground slab, supporting various heavy machinery, and redistribute the loads to the caissons below.

Design Codes

The original codes used by the original plans were BOCA, 1987 Edition, ACI 318-83, AISC, 1980 Edition, A. W. S. D1.1, 1986 or 1988 Edition and CRSI, 1986 edition. This technical report uses ACI 318-08, and ASCE-05 for its reference calculations.

Typical Materials Used

Typical materials that were utilized were varying strengths of concrete. Those specifically specified in the typical details were 4000-5000 psi 28 day strength concrete, with most concrete being 4000 psi strength, while further investigation into the plans revealed at least one call for 1000 psi concrete for use in caissons. Reinforcing steel bars for #4-#11 sizes were to adhere to ASTM A615-60, and stirrups being #3 and #4 were to be of grade 40 steel. For the one way slabs, unless 6x6-w2.0xw2.0 WWF was called for, 6x6-w2.9xw2.9 WWF was the typical wire mesh used.

Gravity Loads

Gravity loads were a combination of dead, live, and superimposed loads. Dead loads were calculated based on existing slab thicknesses and a 150 pcf concrete density. Live loads from plans were used, 125 psf for laboratories, and 100 psf for everywhere else, but for simplicity's sake, 125 psf was used for all locations except the roof. A 30 psf roof load was used for a guideline for calculated snow drift loads. Lastly, a 15 psf superimposed dead load was included for miscellaneous lighting, electrical, HVAC, and plumbing fixtures that may have been otherwise excluded from calculations.

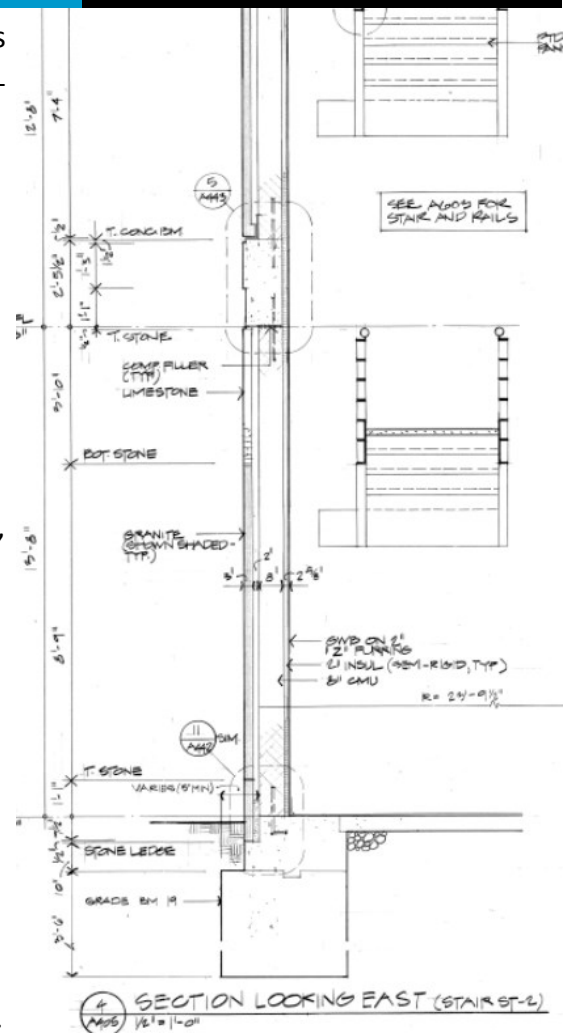

Figure 11. Section of Stairwell

Proposed Depth Topic

The Milton S. Hershey Medical Center Biomedical Research Building as is uses slabs from 8 inches to 12 inches thick. These slabs work well for the existing floor plan and column layout, as well as the two-way slab system. For this thesis, I propose a redesigning of the structural system from reinforced concrete to a steel system using both moment and braced frames. Lateral and gravity systems will both need to be explored.

Multiple iterations will be made, and evaluated in terms of how much the existing floor plan will need to be altered, ideally, none, how much of the dead load can be removed, how torsional effects are changed, column sizes, and how the lateral system is affected. This evaluation will include the original one-way slab system. Each criterion will be explored and explained for each option.

Proposed Breadth Topics

The goal of reducing the thickness of the slab is to reduce the weight of the building, which has a direct correlation with reduced building costs. The first proposed breadth topic will be exploring how costs will change by reducing slab thickness. The second proposed breadth topic will be an investigation of the reduced thermal mass of the building. Thinner concrete slabs from switching to a steel system means less building to either heat or cool, and by extension, can result in additional savings in mechanical systems, which then tie into the first breadth topic. Another breadth topic to be investigated is the environmental impact of the building in the form of CO₂ emissions as a result of construction.

Tasks and Tools

Below is an outline of desired goals to be achieved through the design process of this redesigned space. This can be used as an in-depth view of the table on the next page.

- 1) Research
- 2) Structural Design
 - Various floor systems that produce a smaller slab will need to be developed and evaluated by proposed criteria. Floor layouts will need to be considered.
- 3) Existing Design Check and Modification
 - Check findings from new proposed designs, and check them with existing design, and make appropriate changes if need be.
- 4) Effects on HVAC from proposed system modification
- 5) In-Depth Cost Analysis
- 6) Environment Impact
- 7) Finalize Report
- 8) Jury Presentations
- 9) Update CPEP

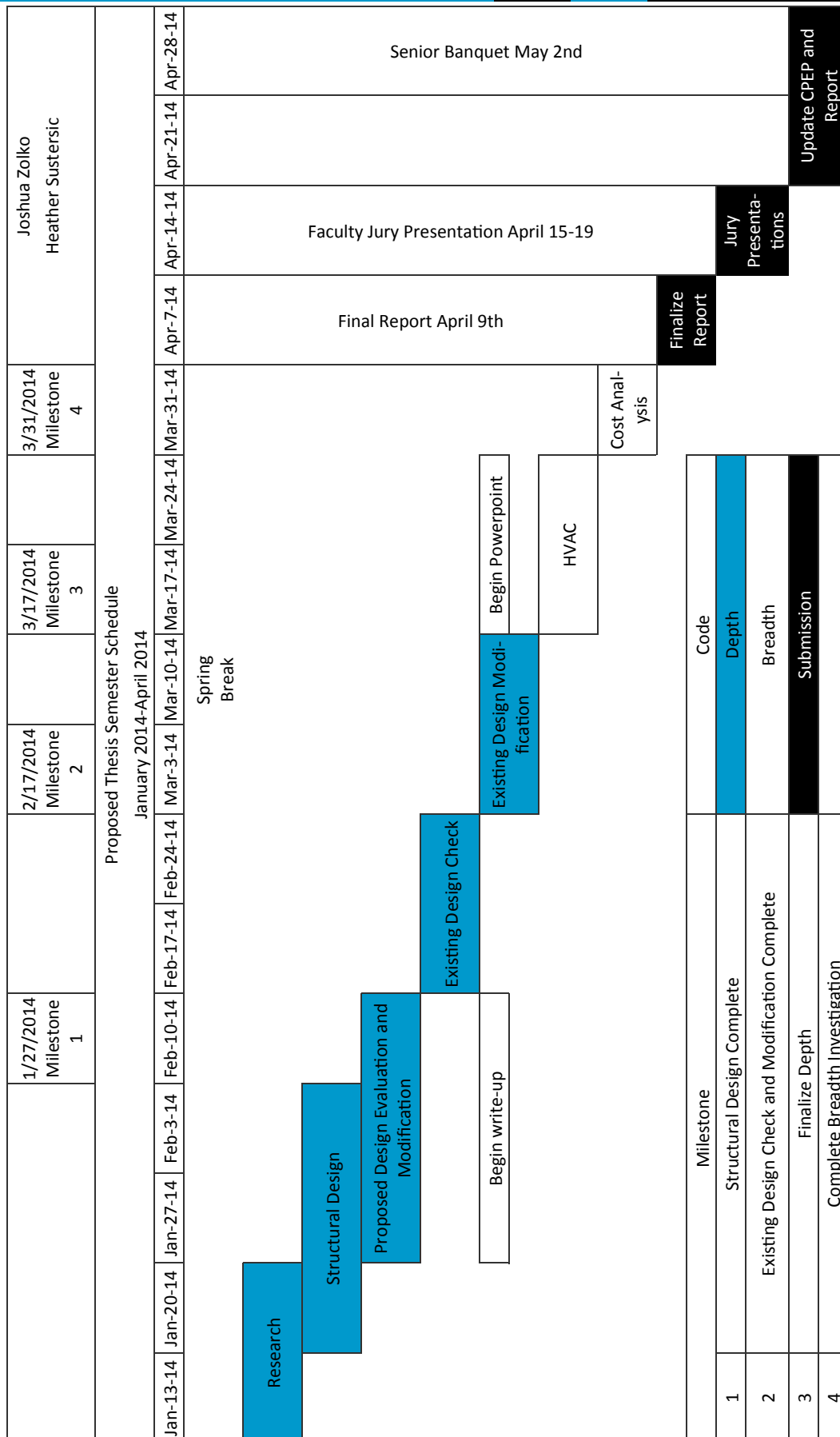

Figure 12.

Conclusion

For the Proposed Thesis topic, the building is to be redesigned using a steel frame. This will require both new gravity and lateral systems to be designed. In addition, cost analysis and changed in thermal mass will be investigated to check for how these factors will be impacted in contrast to the original building plan. Finally, environmental impact will be investigate in order to better make a decision between the two systems.