

Coppin State University  
Physical Education Complex  
Baltimore, MD



Proposal

12/20/07

Todd Drager  
Structural Option  
Faculty Consultant: Dr. Lepage

## Table of Contents:

Executive Summary.....	3
Introduction.....	4
Existing Structural System.....	6
Lateral Force Resisting System.....	7
Arena Trusses.....	8
Problem Statement.....	9
Proposed Solutions.....	10
Solution Methods.....	11
Breadth Studies.....	12
Tasks and Tools.....	13
Timetable.....	14

## Executive Summary:

The Coppin State University Physical Education Complex is a 4 story structure located in Baltimore. The floor framing system is composed primarily of composite steel beams with a concrete slab, typically 3.25" lightweight concrete on a 3"x20ga. galvanized composite metal deck reinforced with 6x6-W1.4x1.4 W.W.F. The lateral system is composed of a mixture of braced frames and moment frames. The roof trusses over the arena also act in the lateral system and provide stability. A 3" expansion joint on each side of the arena and another midway down the east side essentially divide the building into 4 separate sub-buildings, *Facilities Management*, *Arena*, *Physical Education North*, and *Physical Education South*. Typical floor loads are 60psf dead load and 100psf live load. Wind loads typically govern over seismic loads, except in the E-W direction of the arena. This is due to the fact that it is completely enclosed in the E-W direction by the surrounding sub-buildings, namely *Facilities Management* and *Physical Education North*.

As mentioned above, large trusses support the roof of the arena and act as part of the lateral system. The trusses span a total length of 166'-6", but adjacent trusses meet to form triangle sections (in plan view) 45' from the end. See Figure 4 on page 6 for a visual clarification. Special connections are required for the trusses, especially at these triangle areas.

The proposed thesis will explore 2 alternate roof truss systems for the arena as well as 2 breadth studies. The first system I will explore will be a flat roof steel girder with supporting beams, and the second system will be an arched truss system. The current roof is flat, so the first system will keep the flat roof, but the second system will explore a curved roof and its impact on the building as a whole. Cost reduction is very important and will be explored for each alternative, but overall building optimization is also a major concern. Because this is an arena and will host many different activities, building acoustics is a very important issue. For these reasons, the breadth topics will be an acoustics study and a cost/scheduling study.

## Introduction:

The Coppin State Physical Education Complex is a state of the art recreation center surrounding the campus's track and soccer field. The building sprawls in several directions at several heights from the hub of the building, the new 2600 seat arena. The building uses several heights ranging from 30' to 60' and a total area of 135,000 sqft. The main structural system is composed of composite steel with a typical 6.25" lightweight concrete slab. A variety of spaces are all contained within the complex in addition to the arena including an 8-lane swimming pool, racquetball courts, classrooms, and management facilities. Probably the most dramatic features would be the exposed steel trusses supporting the roof of the arena. The building uses IBC 2003 as the main code with references to ASCE 7-05. The building contains 3 expansion joints (see Figure 1), basically subdividing it into 4 separate buildings: *Facilities Management*, *Arena*, *Physical Education North*, and *Physical Education South*. The analyses performed use these sub-divided buildings rather than the structure as a whole. The *Arena* will be the area of further insight and investigation for the duration of thesis.



Figure 1 – Physical Education Complex Sub-Buildings

A rendering of the arena can be seen below in Figure 3. Concrete piers are shown in red, and the other structural elements are steel shapes and are shown in green and yellow. The diaphragms are shown in green also and as is evident only span the south side of the building, which is used as locker, concession and office space. The rest of the space is open from the ground level to the roof.

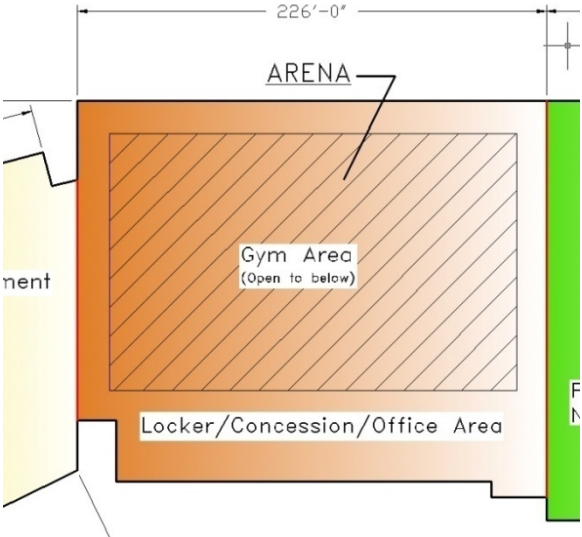

Figure 2 – Arena Spaces

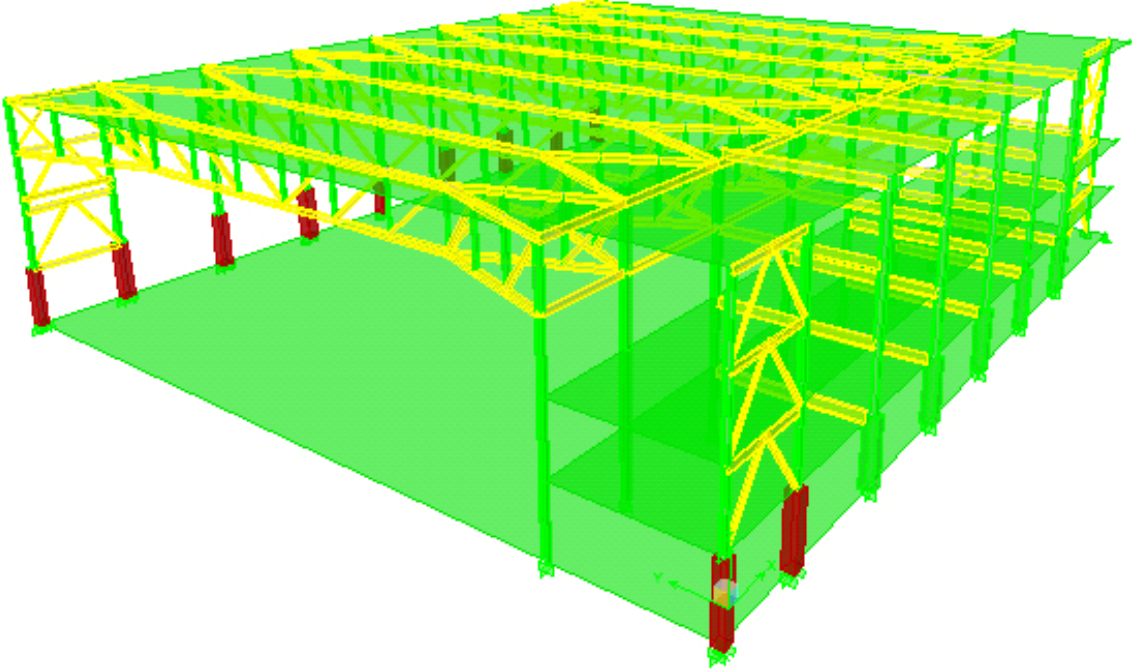

Figure 3 - Arena Rendering

## Existing Structural System:

**Foundation:** The foundation is comprised of spread footings and slab on grade. The spread footings use strengths of 3000psf, 6000psf and 10000psf allowable bearing pressure depending on loads and geotechnical data. The spread footings around the columns range from 4'x4' to 20'x20'. Typical footings are 12" thick, but various thicker footings exist in areas of especially high load such as under the soccer scoreboard. The typical floor slab is 8" thick concrete slab-on-grade reinforced with 6x6 W2.1x2.1 W.W.F. on waterproofing and 6" compacted granular fill, compacted to at least 95% of the maximum density as defined by the Modified Proctor Test. The concrete used is normal weight and has a minimum compressive strength at 28 days as follows:

Footings: 4000psi

Caisson Caps: 4000psi

Caissons: 4000psi

Walls + Piers: 4000psi

Grade Beams: 4000psi

Slab-On-Grade: 3500psi

The reinforcement bar strength is  $f_y=60$ ksi for all areas.

**Floor System:** The floor system of the *Arena* of the Coppin State University Physical Education Complex is composed primarily of composite steel beams with a concrete slab, typically 3.25" lightweight concrete on a 3"x20ga. galvanized composite metal deck reinforced with 6x6-W1.4x1.4 W.W.F. All concrete in the superstructure uses an  $f'_c = 4000$ psi. The beams are typically spaced at 10' intervals (with few exceptions due to vertical openings) to eliminate shoring during construction. Supporting girders are spaced typically at 31'. There is not much conformity of W shape sizing throughout the building due to its odd shape and different loading and spanning conditions.

**Columns:** The columns of the Coppin State University Physical Education Complex are mostly W shapes. W12's are the most common, but W10's and W14's are also used. The columns supporting the roof trusses are W14x257's. Square HSS shapes are also used as columns but rarely and none occur on the arena area. The building uses steel gravity columns as well as moment framed columns. Because the building is only 4 stories maximum, there is only one splice maximum per column line, which generally occurs on level 3. Splicing is specified as 4' above the finished floor which makes the longest column 34'. The lightest W shape used is W10x33 and the heaviest is W14x257. All columns are A992 with minimum yield strength of 50ksi.



## Lateral Force Resisting System:

The lateral system for the *Arena* is composed of braced frames in the E-W direction and moment frames accompanied by the roof trusses in the N-S direction. The lateral system can be seen below in Figure 2. Each lateral member is numbered T1 through T17 for referencing.

\*Members T1 through T4 are braced frames.

\*Members T5 through T9 are moment frames.

\*Members T10 through T17 are roof trusses.

\*The space directly under the roof truss members (T10-T17) is open space from the bottom of the trusses to ground level (No diaphragms).

\*Piers extend to the bottom of floor 1 (15' above ground level) under braced frames T1, T2, and T3 as well as under the W14x257 columns supporting the roof trusses on the north side.

\*Floor diaphragms exist only in the locker/concession/office area. For this reason the braced frames on the northern part of the building (T1 and T2) take very little lateral load. The load they do receive is primarily transferred by the roof diaphragm and through torsion. Their primary function is stability. They brace the large W14x257 columns and provide additional redundancy and support.

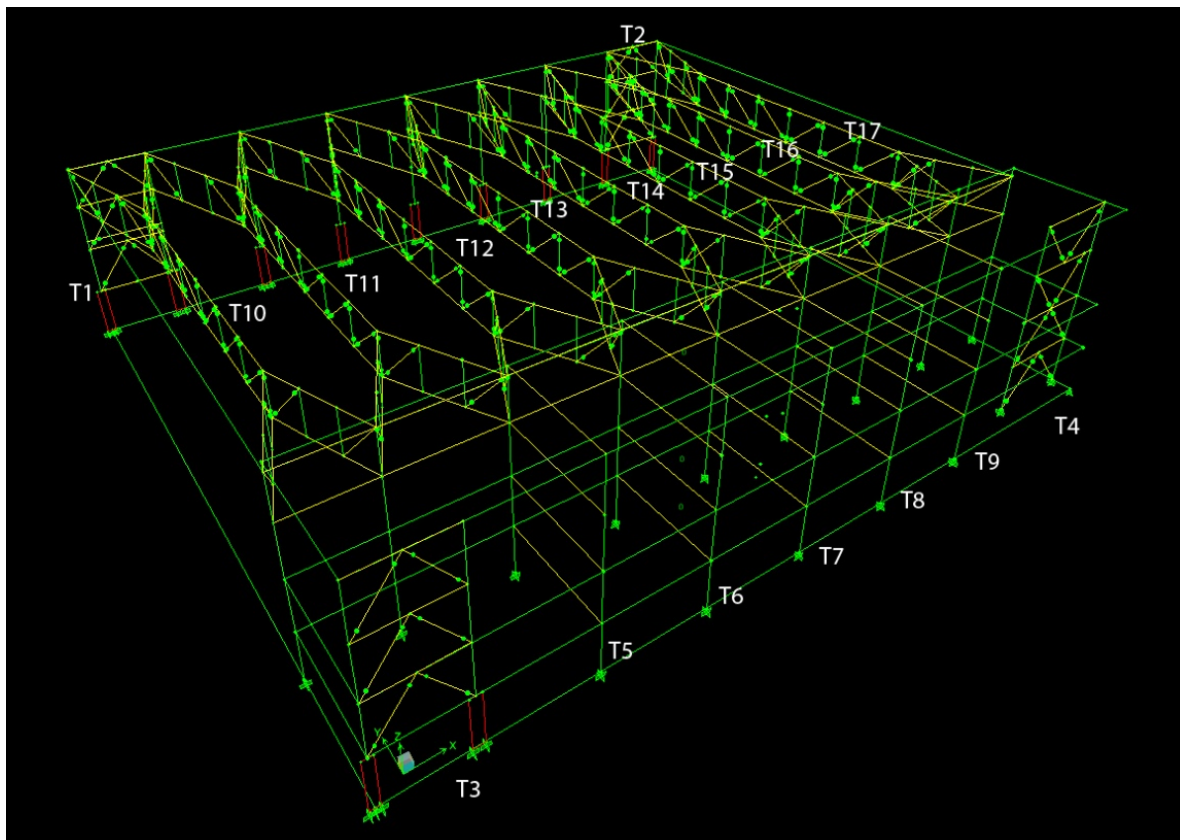

Figure 4 - ETABS Model of Lateral System

## Arena Trusses:

The Coppin State University Physical Education Complex makes use of several trusses supporting the roof structure of the arena. The trusses act as gravity members by taking the roof gravity loads and also as part of the lateral system. The span of these trusses is 166'6". W14x120's make up the top and bottom chords and HSS8x8x1/2's make up the diagonal members. The depth of the trusses is 10'7". The trusses do not span the 166'6" continuously, but rather the adjacent trusses meet about 45' from each end forming a triangle section (see Figure 5 for visual clarification). The trusses are generally flat with a small slope for water runoff. Special connections are required at the midspan and intersection of the end triangle pieces. Figure 5 shows a plan view of the trusses and the amount of shear taken by each roof truss as well as the other lateral members at the roof level.

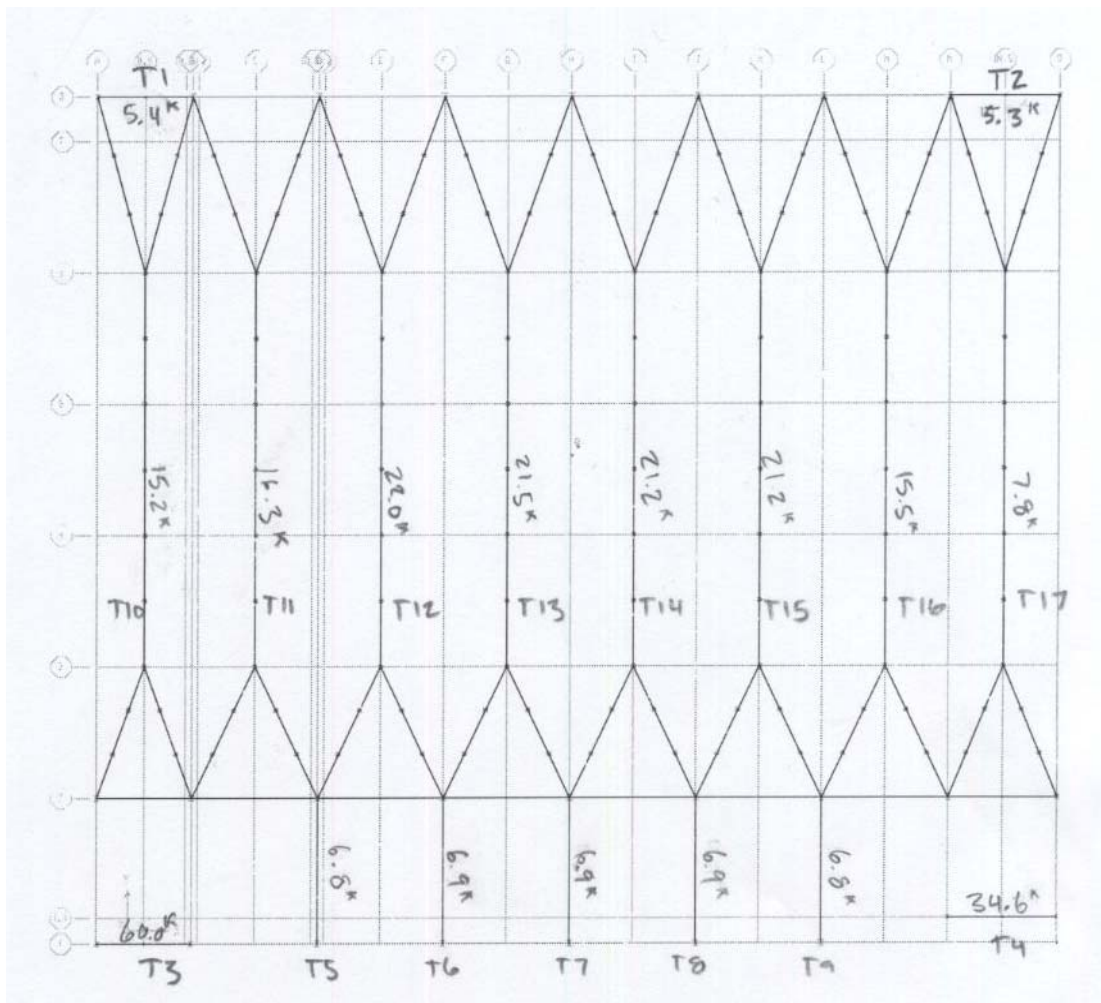

Figure 5 - Plan of Roof Trusses and amount of shear taken by each



### Problem Statement:

To this point both the current gravity system and the current lateral system have been analyzed and proven to be adequate and successful systems for the building type and location. Technical report 2 analyzed possible alternative framing systems and showed that the current composite system is a very good selection for the Coppin State Physical Education Complex. Technical report 3 analyzed the current lateral system of the arena and showed it to satisfy all requirements including drift, torsion, and strength requirements. Spot checks also showed the arena roof trusses to be sufficiently designed. These trusses, however, are worth looking into further. Much of the cost of the building will come from the materials and installation of this specific area. The focus for the remainder of thesis will be on these roof trusses. The goal will be analyzing and reducing overall costs, but architectural and acoustical impacts will also be seriously considered. The redesign will focus on material costs, scheduling implications, labor costs and contractor issues with an overall aim of reducing total costs.

### Proposed Solutions:

To investigate possible cost savings, acoustical improvements or architectural changes, 2 different roof truss systems will be looked into. The first system will be a steel girder clearspan with supporting beams, and the second system will be an arch truss system. Cost savings could come from the materials themselves, from installation ease, or from scheduling implications.

#### Steel Girder Clearspan:

The steel girder clearspan will be looked into because of its lack of special connection needs. The current roof truss system uses many special connections, especially at the intersection of the triangle sections. With a steel girder clearspan these connections would be eliminated. However, there will most likely need to be splices along the girders, or special orders will need to be made from the steel mill because girders are not typically cut 166'-6" long. The cost of these splices or special orders versus the current connections will be compared and an overall price assessment will be made.

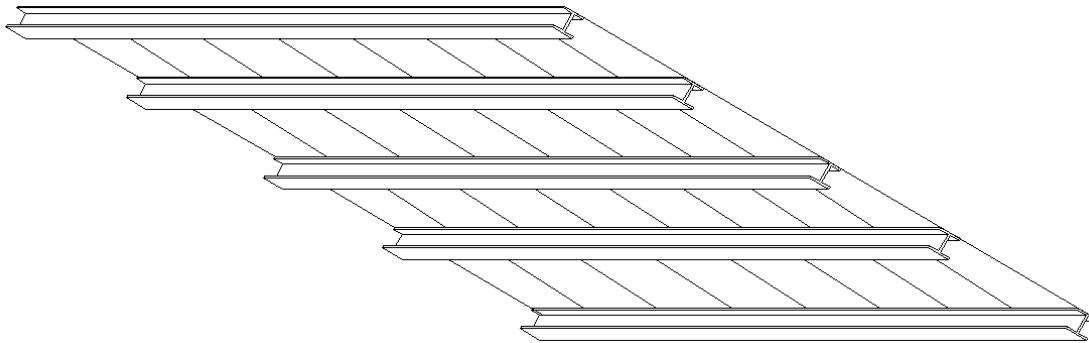

#### Arch Truss:

The arch truss system will be investigated as a possible alternative to the current system. The benefit of using the arched truss as compared to the flat truss is that individual members can typically be smaller due its curved shape. With this system, the costly connections at the previously mentioned triangle section can also be eliminated. The curved nature of this system provides a different look to the arena and could possibly help with aesthetics.

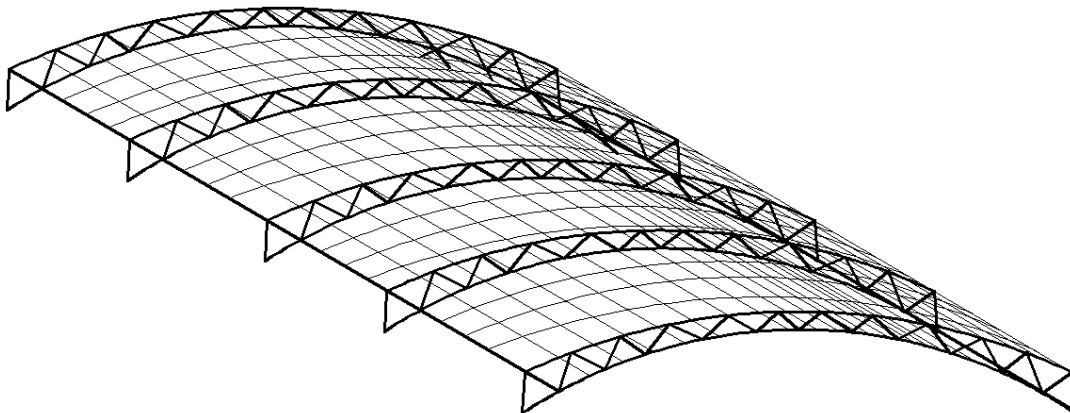

## Solution Methods:

### Steel Girder Clearspan:

First, calculations will be done to size the steel members based on The American Institute of Steel Construction LRFD (AISC) 9<sup>th</sup> Edition. Both gravity and lateral loads need to be considered for this. Because this is a roof structure, special load patterns will also need to be considered. Snow drift and partial loading must be calculated and designed for. A computer model will be developed on ETABS and help with the analysis. Next, splices will need to be determined. If the girders can be cut to the exact length, prices will need to be gathered from the steel mill for special orders. Material weight will need to be considered and if the new system increases the weight, foundation sizes will need to be reevaluated. The current foundation uses spread footings, but they may need to be changed if the weight increase is significant. Lastly, scheduling implications will need to be figured out. I will need to consult with professionals on this and obtain specific information for arena designs. Acoustics will also be analyzed for the flat roof system. The total cost will then be tallied and compared with the current system.

### Arch Truss:

Typical arch trusses will be researched and the appropriate size will be determined. Since steel will be the primary material, The American Institute of Steel Construction LRFD (AISC) 9<sup>th</sup> Edition will again be used to size the members. Load patterns and snow drift issues will play an important role in the design. Uneven load patterns on arch supported structures have had a problem in past, so this area will need to be addressed in full detail. Typical flange shapes will need to be determined first. Typical sizes for both flange and web members will next be determined. Material weight will need to be considered and the foundation will be redesigned if necessary. Roofing material will also be looked. Because the roof will change shape significantly with this option, waterproofing or finding adequate pliable roofing material could be an issue. Scheduling implications and constructability will also be determined. Acoustics will be analyzed and compared with the current flat roof to check if any additional costs or savings would be involved with the arched roof. The total cost will be tallied and compared with the current system.

## Breadth Studies:

### **Construction Management:**

Because of the unique connections that could possibly cause difficulty with construction, accessibility, and overall cost to building, the first breadth topic will consist of a cost and scheduling analysis between the current system and the proposed solutions. Material cost is relatively easy to compute, but the labor costs will require a more in depth analysis. In order to compute labor costs, RSMeans will be looked at for general data, then information on past projects using these systems will be examined. I plan on finding the savings or losses for each system for material cost, labor cost and total cost, then make a recommendation based on pure cost alone.

### **Acoustics:**

Acoustics will be examined for the current flat roof system and compared with the proposed arch roof system. The arena will incorporate several different uses, including sports, assemblies, speeches and student gatherings. Acoustics plays an important role with all of these activities, so it is important to examine and plan for all situations. The arena will have seating at various levels so different heights will need to be analyzed. The overall shape of the arched roof will be re-examined and possibly re-designed based on acoustic information. Acoustical padding or damping material will also be investigated for the roof as well as for the walls between the arena and the other adjacent areas. If the arena is in full use, but office occupants are still present, it is important that they have an adequate sound barrier.

## Tasks and Tools:

### Structural:

- 1) Research arched truss designs
- 2) Research and choose steel shapes for arched members
- 3) Evaluate controlling load patterns and snow drift cases
- 4) Construct ETABS Model
- 5) Design both roof systems
- 6) Determine connections details for arched trusses
- 7) Evaluate foundation changes

### Construction Management:

- 1) Determine current and proposed system material costs
- 2) Determine labor costs with RSMeans
- 3) Consult with past projects and consultants for changes to labor costs
- 4) Determine constructability and scheduling implications
- 5) Determine overall system costs and savings

### Acoustics:

- 1) Determine areas of acoustic concern
- 2) Research acoustic damping systems
- 3) Calculate acoustic needs
- 4) Suggest possible materials or alternative to the present system

### General:

- 1) Edit and revise paper
- 2) Publish and edit cpep

Timetable:

Schedule	
Task	Week
	1 2 3 4 5 6 7 8 9 10 11 12 13 14
Research arched truss designs	1-2
Research and choose steel shapes for arched members	2-3
Evaluate controlling load patterns and snow drift cases	3-4
Construct ETABS Model	4-5
Design both roof systems	5-6
Determine connections details for arched trusses	6-7
Evaluate foundation changes	7-8
Determine material costs	8-9
Determine labor costs with RSMMeans	9-10
Consultation and revision to labor costs	10-11
Determine constructability and scheduling implications	11-12
Determine overall system costs and savings	12-13
Determine areas of acoustic concern	13-14
Research acoustic damping systems	14
Calculate acoustic needs	1-2
Edit and revise paper	2-3
Publish and edit cpep	3-4
PRESENTATIONS	4-5
Relax	5-6