

PROJECT PROPOSAL

FOR THE INVESTIGATION OF
ALTERNATIVE MECHANICAL SYSTEMS

UNIFIED SCIENCE CENTER

THE UNIVERSITY OF SCRANTON

SCRANTON, PA



DALE E. HOUCK | MECHANICAL

CONSULTANT: DR. BAHNFLETH

10 DECEMBER 2010

PENN STATE UNIVERSITY ARCHITECTURAL ENGINEERING

TABLE OF CONTENTS

EXECUTIVE SUMMARY	3
MECHANICAL SYSTEMS SUMMARY	4
Introduction.....	4
Design Criteria and Objectives.....	4
Design Conditions.....	5
Equipment Summary.....	6
Design Ventilation, Loads, and Energy.....	8
Systems Operations Summary.....	9
Overall Evaluation of Systems as Designed.....	12
PROPOSED ALTERNATIVE SYSTEMS	13
Heat Recovery Wheels.....	13
Chilled Beams.....	14
Variable Air Volume AHUs.....	14
BREADTH TOPICS	15
Architecture/Sustainability.....	15
Electrical.....	15
PROJECT METHODS	16
PRELIMINARY RESEARCH	16
PROPOSED WORK SCHEDULE	17

EXECUTIVE SUMMARY

The purpose of this report is to provide a summary of the existing design of the Unified Science Center and propose alternative design solutions based on the design criteria and objectives established by the owner. Information from each of the three previous technical reports is included, followed by descriptions of the alternatives to be considered, project methods and research, and a draft work plan for the spring semester.

The Unified Science Center is designed to be supplied with 100% outside air from (5) rooftop air handling units with total energy recovery wheels, atomizing fog humidifiers, and variable volume supply fans. Analysis of these air handling units is included in this report with respect to ventilation and thermal comfort.

After researching many different techniques for laboratory space conditioning and ventilation, three methods were identified as appropriate for this project: a sensible heat recovery wheel to be used in conjunction with the enthalpy wheel already designed; an active chilled beam system to help reduce costs and emissions; and a standard VAV system with terminal reheat to provide a reference for the current design.

In addition to these studies of the building's mechanical systems, it is proposed that work be completed on architecture and sustainability efforts in addition to electrical systems. These breadth areas are closely related to the design and performance of HVAC systems, and therefore have an effect on the carbon footprint of this building.

This report concludes that the mechanical systems of the Unified Science Center are extremely well designed and suited to the requirements of the project, though the costs associated with a 100% outside air system are significant. Nonetheless, the HVAC systems comply with relevant ASHRAE standards and provide a significant number of LEED points toward the goal of Silver certification. Still, the redesigns proposed in this report have the potential to save even more energy over the lifetime of the building.

MECHANICAL SYSTEMS SUMMARY

Introduction

The Unified Science Center is an approximately 200,000 ft² teaching and research facility on the campus of The University of Scranton in Scranton, Pennsylvania. New construction accounts for about 150,000 ft², and is seamlessly integrated with the renovation of an existing campus building. The building houses departments of biology, chemistry, computing sciences, physics, electrical engineering, and mathematics, and the program includes offices, classrooms, laboratories, computer rooms, lounges, and a vivarium dedicated to animal research.

Design Criteria and Objectives

The primary objective of any HVAC system is to provide proper ventilation and thermal comfort to the occupants of the building by maintaining specified ventilation rates and a comfortable temperature and humidity level. In doing so, it is also desirable to minimize operational costs for the life cycle of the building.

Given the nature of the spaces in the Unified Science Center, indoor air quality is a significant concern; the number of laboratories demands that the HVAC system be capable of providing a large amount of outdoor air to properly ventilate spaces, rapidly clear rooms of lab spills and vapors, and minimize the recirculation of potentially dangerous contaminants.

While such safety concerns primarily drive the design of the HVAC system, the Unified Science Center is also subject to a variety of other factors influencing mechanical systems design. Large equipment loads resulting from laboratory facilities and computers, in combination with considerable design occupancy loads, provide significant internal loads to be dealt with during the cooling season. In addition, generous fenestration subjects large portions of the building to significant solar gain, making perimeter spaces critical.

The L-shaped building lends itself to a centralized HVAC system on the penthouse level. The architectural layout of the building is also conducive to efficiency of HVAC layout; each floor is generally laid out identically, with offices, laboratories, and classrooms occupying similar positions on each level.

Finally, the owner's design intent is to achieve LEED Silver certification, making the Unified Science Center the first LEED certified building on the University of Scranton campus. Mechanical system efficiency is critical in pursuit of this goal, and accordingly should be given considerable emphasis in the design of HVAC systems.

Design Conditions

The selection and design of HVAC systems is heavily influenced by indoor and outdoor design conditions. Northeastern Pennsylvania experiences harsh winters and hot summers, as evidenced by the ASHRAE design conditions shown in Table 1.

ASHRAE Design Conditions – Scranton, PA		
	Dry Bulb Temperature (°F)	Wet Bulb Temperature (°F)
Cooling	88.9 (0.4%)	72.1 (0.4%)
Heating	3.5 (99.6%)	-

Table 1

Indoor design conditions vary according to season and occupancy, while the vivarium maintains its own requirements as a result of the unique nature of the space. Setpoints were taken from the project documentation, and are shown in Table 2.

Indoor Design Conditions		Summer		Winter	
		DBT (°F)	RH (%)	DBT (°F)	RH (%)
Offices, Classrooms, Laboratories	Occupied	75	55	70	30
	Unoccupied	78	60	65	25
Vivarium	Occupied/Unoccupied	72	55	72	50

Table 2

Equipment Summary

Based upon the design requirements, objectives, and conditions, the engineers devised an MEP system that responds directly to the specificities of this project. With indoor air quality being the primary concern, 100% outside air is provided to the building with (4) coupled 50,000 CFM AHUs utilizing energy recovery wheels and variable frequency drives. A similar 5,150 CFM unit is dedicated to vivarium spaces. Table 3 provides a summary of the AHUs.

Air Handling Units				
	Total Fan CFM	Total Supply CFM	Heating Coil Capacity (MBH)	Cooling Coil Capacity (MBH)
AHU 1	52,626	50,000	3430.6	5364
AHU 2	52,626	50,000	3430.6	5364
AHU 3	52,626	50,000	3430.6	5364
AHU 4	52,626	50,000	3430.6	5364
AHU 5	5,746	5,150	323	525.5

Table 3

Two water-cooled, electric motor driven, centrifugal chillers are to be used in the Unified Science Center. A summary of this equipment is found in Table 4.

Water-Cooled Chillers							
	Capacity (Tons)	Efficiency (kW/Ton)		Evaporator (°F)	Condenser (°F)	Electrical	
		EER	NPLV	EWT/LWT	EWT/LWT	MCA	MOCP
CH 1	550	0.548	0.344	56/44	85/95	545	800
CH 2	550	0.548	0.344	56/44	85/95	545	800

Table 4

Two rooftop cooling towers serve the chillers, and are summarized in Table 5:

Cooling Towers					
	Nominal Capacity (Tons)	Design WBT (°F)	EWT (°F)	LWT (°F)	Fan Motor (HP)
CT 1	550	76	95	85	25
CT 2	550	76	95	85	25

Table 5

Heating hot water is provided by (8) natural gas fired condensing boilers located on the penthouse level. Each boiler operates identically; a summary of a typical boiler is provided in Table 6:

Natural Gas Fired Boilers (typ.)							
	Gas Input (MBH)	Net IBR Output (MBH)	EWT (°F)	LWT (°F)	Min/Max Flow (GPM)	Efficiency (%)	Electrical FLA
B-x	1999	1760	150	180	25/120	87	11

Table 6

Information pertaining to end suction pumps is summarized in Table 7:

Pumps						
	Service	GPM	Head (ft)	BHP	HP	RPM
P 1	Chilled Water	1100	95	33.19	40	1760
P 2	Chilled Water	1100	95	33.19	40	1760
P 3	Chilled Water	1100	95	33.19	40	1760
P 4	Condenser Water	1650	65	30.75	40	1760
P 5	Condenser Water	1650	65	30.75	40	1760
P 6	Condenser Water	1650	65	30.75	40	1760
P 7	Heating Hot Water	480	90	14.24	20	1760
P 8	Heating Hot Water	480	90	14.24	20	1760
P 9	Heating Hot Water	480	90	14.24	20	1760

Table 7

Design Ventilation Requirements

In Technical Report 1 – *Compliance Evaluation of ASHRAE Standards 62.1 and 90.1*, an analysis was performed to verify compliance with ASHRAE Standard 62.1 – *Ventilation for Acceptable Indoor Air Quality*. This report concluded that the systems and equipment of the Unified Science Center are properly designed to achieve acceptable indoor air quality, and in many cases exceed the requirements set forth by ASHRAE. While detailed analysis can be found in Technical Report 1, a summary of its results is given by Table 9.

	Capacity (CFM)	Required OA (CFM) Vot	Design OA (CFM) Vpz	Oversupply (CFM)	Max Zp	Ev	Compliance
AHU-5	5,150	870	5050	4180	0.247	0.8	YES
AHUs 1 and 2	105,252	21,506	102,475	80969	0.446	0.7	YES

Table 9

Design Heating and Cooling Loads

In Technical Report 2 – *Building and Plant Energy Analysis*, heating and cooling loads were simulated using Trane TRACE. The modeled values found in Technical Report 2 are generally similar to those in the design documents, with the notable exceptions of the heating load and the supply air rate for AHU 5. Difficulty in accurately modeling the complexities of the system in conjunction with zoning issues likely accounts for these discrepancies; subsequent attempts to improve the model have not yielded significantly better results. Since the results of this analysis were heavily skewed by the heating load, it will be necessary to perform a new simulation to provide more accurate figures to compare with the alternative designs proposed later in this report.

Annual Energy Consumption, Source Rates, and Costs

In Technical Report 2 – *Building and Plant Energy Analysis*, annual energy use was simulated using Trane TRACE. Estimates produced by the software can be found in Technical Report 2; however, as a result of the inaccurate heating load noted above, the results for energy consumption and costs as well as emissions are accordingly skewed and will be reconsidered before comparison with design alternatives.

Systems Operations Summary

Figure 1 shows the overall airflow diagram for the 5 air handling units. Not shown in this figure due to space constraints is the outdoor air supplied to each AHU.

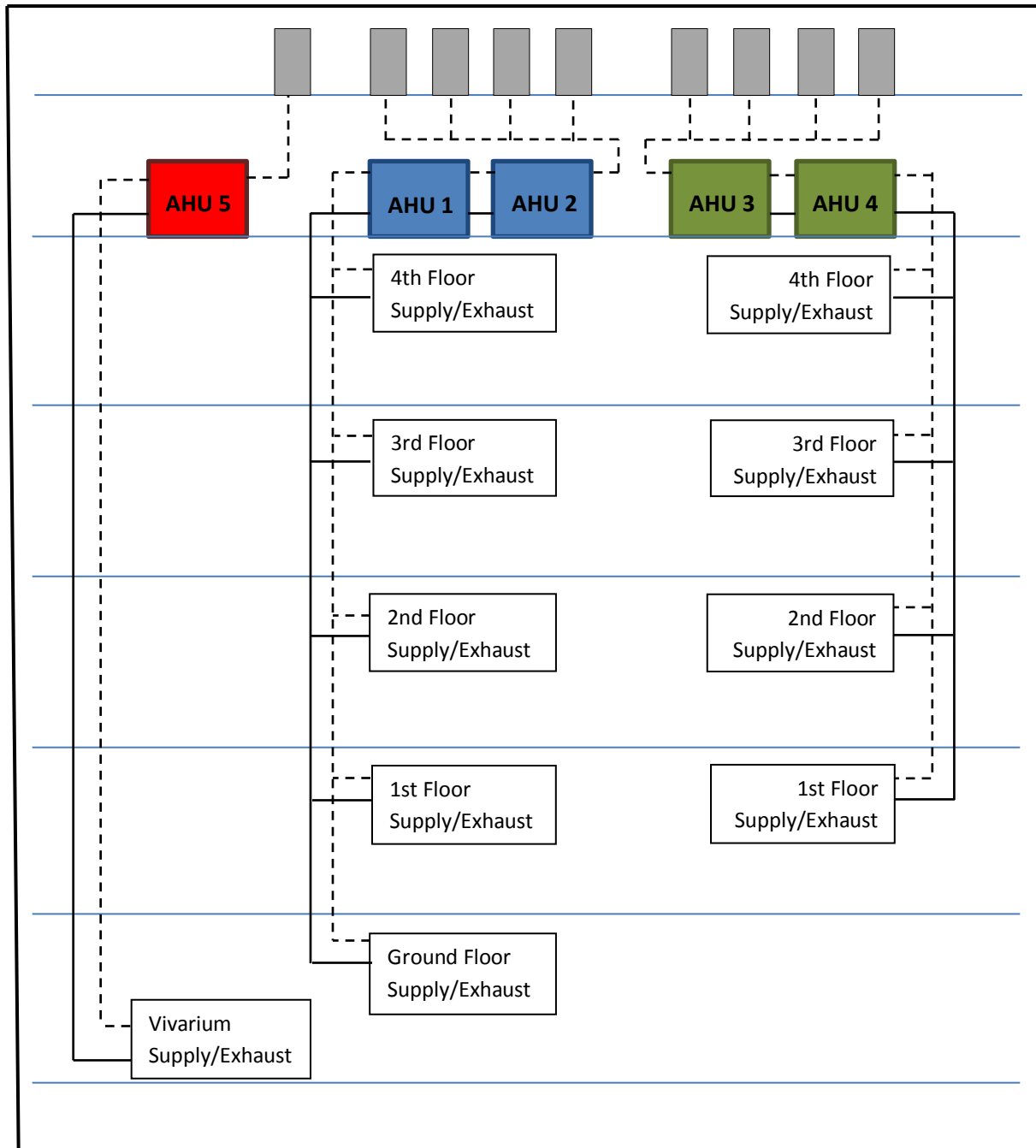

Fig. 1

Each AHU is equipped with a variable frequency drive to modulate supply fan speed and maintain static pressure above 1.5" of water. The exhaust fans operate in unison with the supply fans, and also have variable frequency drives. To maintain the setpoints (refer to Table 2), the energy recovery wheels (ERWs) are the primary source of heating and cooling; the hot water coil and chilled water coil will provide supplemental heating and cooling if the ERWs cannot maintain the discharge temperature setpoint. The Building Automation System (BAS) modulates the ERW speed, hot water valve, and chilled water valve to achieve the desired temperature. In the case of cold temperatures (less than 40 °F), the hot water valve will open proportionally to temperature, and the ERW speed is reduced to prevent frost buildup.

Figure 2 shows the typical configuration of each AHU:

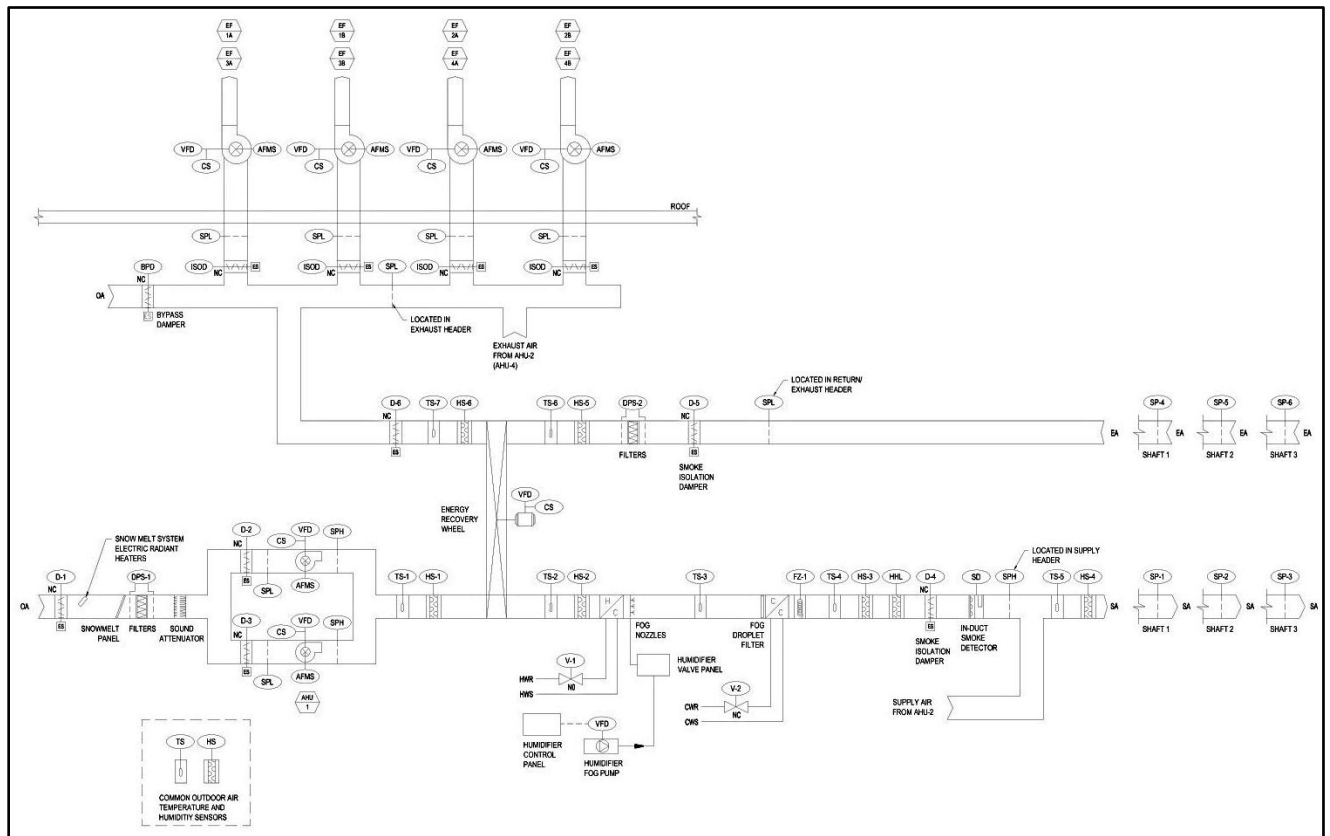

Fig. 2

Figures 3 and 4 show the chilled and hot water flow diagrams, respectively.

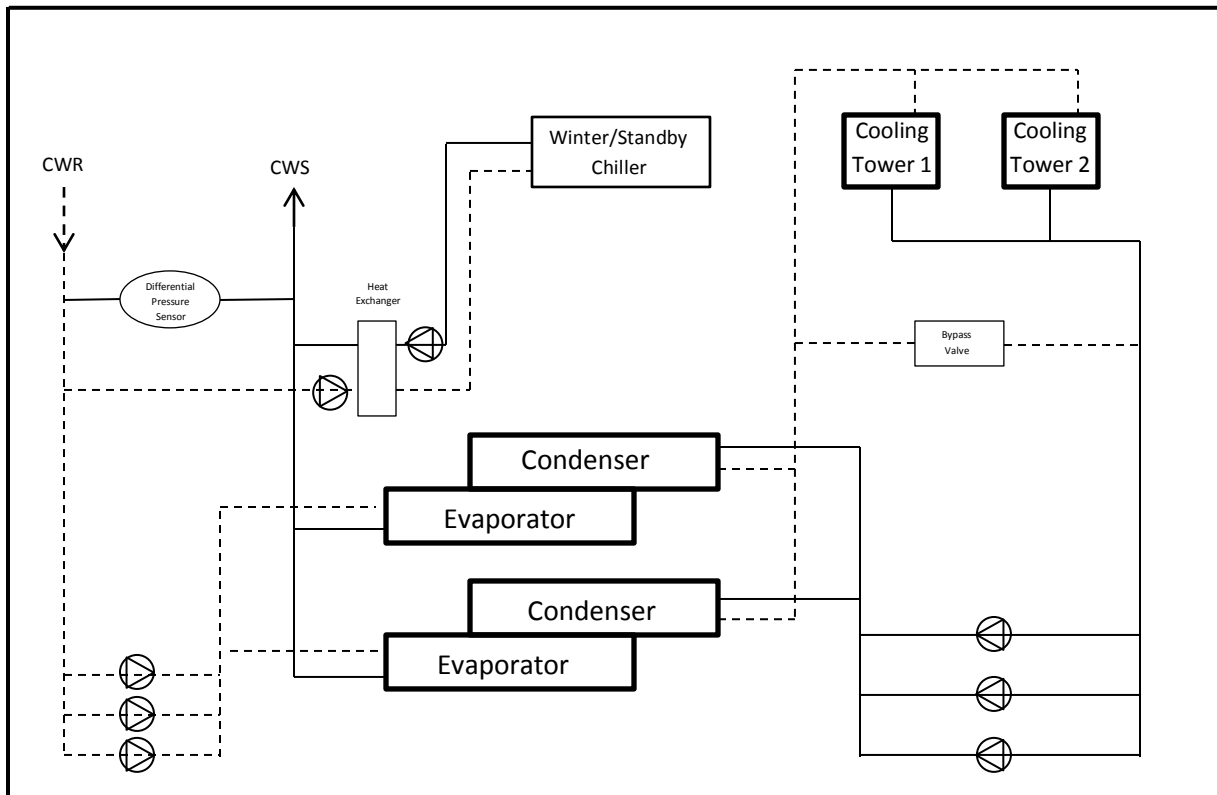

Fig. 3

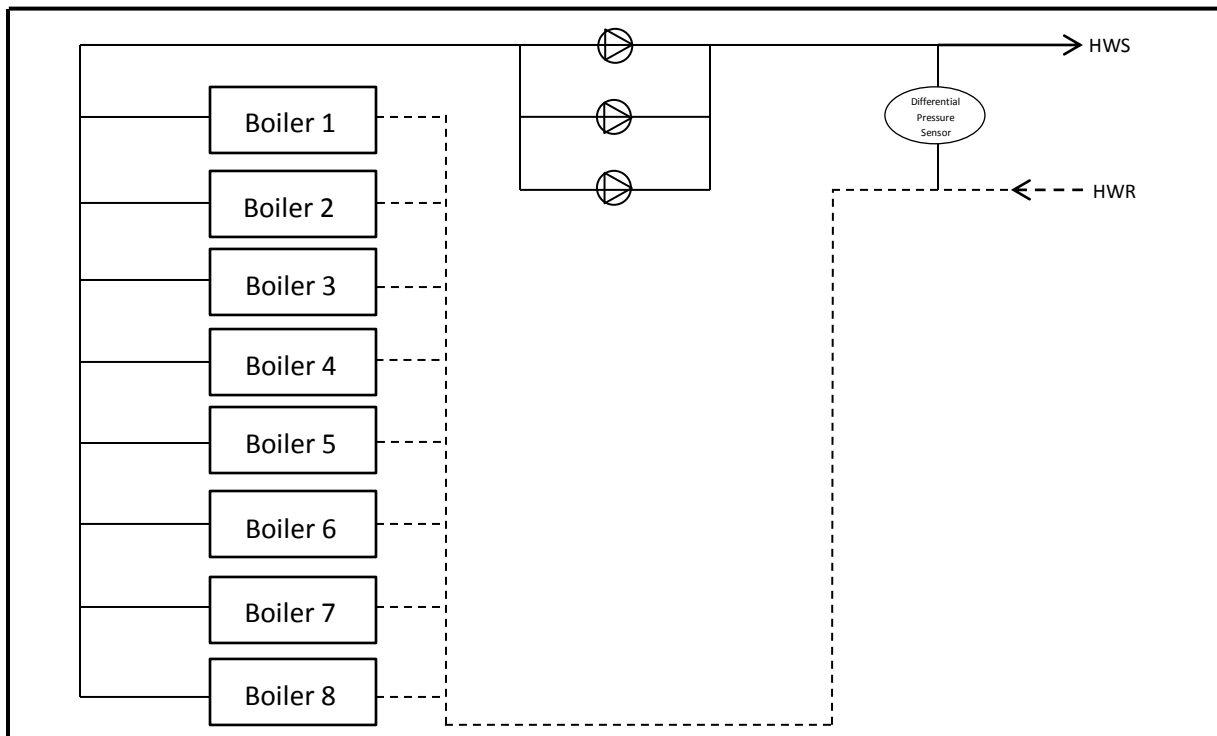

Fig. 4

Overall Evaluation of Systems as Designed

In general, the mechanical systems of the Unified Science Center are well thought out and expertly designed to achieve the goals set forth by the owners. Potential safety risks involving recirculation of contaminants from laboratory spaces have been entirely avoided by using 100% outside air handling units, though this design choice has in turn magnified heating fuel consumption and costs.

The layout of the mechanical systems and duct shafts is nicely integrated with the architecture of the building, providing efficiency in construction and maintenance. In addition, the equipment used in the design boasts high efficiency, offsetting the costs incurred by the air handling units. Overall, the mechanical systems of the Unified Science Center comply with relevant ASHRAE Standards and are designed to push the building toward LEED Silver Certification.

Great care was taken in the design process to provide mechanical, electrical, and plumbing systems that are appropriate for this project. The factors that most heavily influenced design were occupant safety and energy efficiency, so any alternatives to be considered must meet these criteria at a minimum.

Since the results produced by Technical Report 2 - *Building and Plant Energy Analysis* were skewed by inaccurate modeling, they are not considered a realistic portrait of the future performance of the building in terms of loads, energy use, and emissions. It will therefore be crucial to produce a revised model against which to compare the redesigns that will be performed in the Spring semester. In addition to the creation of a new Trane TRACE model, it will also be desirable to complete a load and energy analysis in eQUEST so that the results from each program may be compared and averaged to provide a basis of analysis for the proposed redesigns.

PROPOSED ALTERNATIVE SYSTEMS

While the mechanical systems are well designed to meet the requirements of relevant ASHRAE Standards and LEED Certification, there are several alternatives that may further reduce purchased energy consumption and operating costs. The primary objective of proposed alternatives is to reduce the Unified Science Center’s carbon footprint while satisfying the criteria established by the owners. In addition, it will be useful to analyze the use of a more typical HVAC system in this building to identify the advantages of the current design over a standard approach to ventilation, temperature, and humidity control. The alternatives discussed in this report include heat recovery wheels and chilled beams to improve energy efficiency, as well as analysis of the potential use of Variable Air Volume air handling units to provide a reference for the performance of the current design.

Heat Recovery Wheels

Each of the AHUs is currently equipped with a total energy recovery (enthalpy) wheel, which transfers both latent and sensible heat between the exhaust and supply airstreams. While this is an effective method to provide supply air at a reasonable temperature, it is easily augmented through the addition of a heat recovery wheel that transfers only sensible heat. Based on comparisons of the simulated performance of each configuration, the dual-wheel configuration outperforms a single enthalpy wheel in terms of heating energy use by eliminating the need for a heating coil downstream of the wheel, and significantly reducing the need for space reheat. Figure 5, from Dr. Stanley Mumma’s ASHRAE Journal article *Designing Dedicated Outdoor Air Systems*, illustrates the differences between these two configurations:

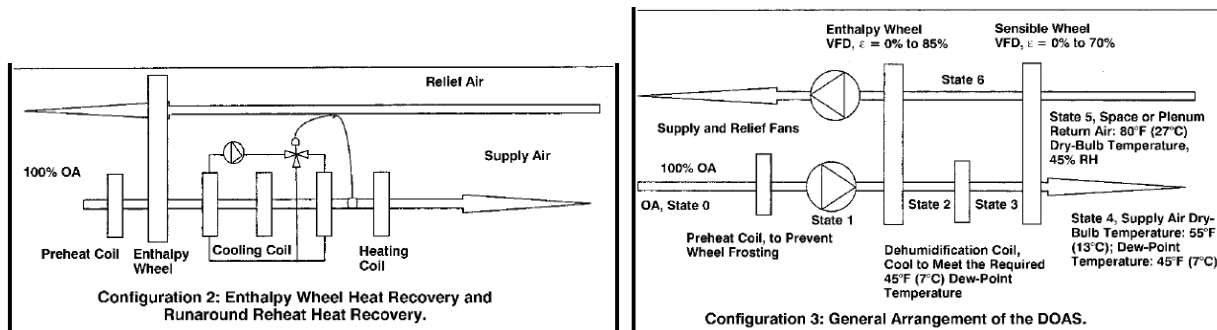

Figure 5

Chilled Beams

Active chilled beams have been in use for many years in Europe, but only recently have they been considered a feasible alternative to conventional HVAC systems in the United States. Since a Dedicated Outdoor Air System is already in use in the Unified Science Center, the use of active chilled beams has the potential to further reduce the energy required to provide local cooling, and would also significantly reduce construction cost and floor-to-floor height as well as the required size of the AHUs, chillers, boilers, and ducting.

The greatest drawback to the use of chilled beam systems is the possibility of condensation, which results from uncontrolled humidity in the space. However, this can be avoided with appropriate sizing and ventilation air. In some laboratory spaces, the use of chilled beams prompts high safety airflow rates because of fume hood exhaust rates, and distinct airflow patterns require chilled beams to be configured properly to prevent the possibility of contamination. Fortunately, the majority of the laboratory spaces in the Unified Science Center do not have a high density of fume hoods, though many labs in the new construction have large areas of fenestration which may present difficulties with condensation. Even so, these and a large number of labs and classroom spaces being renovated as part of this project stand to benefit from the use of chilled beams for space conditioning.

Variable Air Volume AHUs

Since the current design of the Unified Science Center incorporates cutting edge technology in its mechanical equipment and controls, it has been shown in the first three technical reports that this building's indoor air quality and energy performance exceeds that of more traditional approaches to HVAC systems for buildings of this type. However, it would be helpful to establish a definition of a "traditional approach" and implement it in this project to provide a reference for the mechanical systems as designed. For the purposes of education, this approach would be valuable to understand the advantages a Dedicated Outdoor Air System offers over a standard solution for these types of spaces.

A traditional approach would be a VAV supply air system with VAV terminal reheat. According to Philip Bartholomew's article *Makeup Air Heat Recovery: Saving Energy in Labs*, these standard VAV systems waste large amounts of both refrigeration and heat input energy. By analyzing this type of system in the Unified Science Center, it will be possible to identify the ways in which this energy is wasted and in what ways the current design outperforms it.

BREADTH TOPICS

The focus of breadth studies proposed in this report is to complement the study of mechanical systems by investigating the impact of other building systems on the HVAC requirements. In addition, sustainability plays a large role in the design of this building, and it would be advantageous to identify additional methods to reduce this building's carbon footprint and accumulate LEED points for future certification. This will require a broad study of sustainable architecture applications and an examination of the Unified Science Center's electrical system.

Architecture/Sustainability

Though the architecture of the Unified Science Center is already expertly designed to achieve energy efficiency and a comfortable aesthetic, it would be valuable to explore other architectural options that would both complement the current design and improve energy performance. For example, much of the building's fenestration is designed to be shaded with horizontal louvers; light shelves or other shading devices might provide a better-performing alternative to provide daylighting, minimize solar heat gain, and add architectural interest.

Large copper panels crown the building to hide mechanical systems; given the significant south- and west-facing areas of these panels, it would be worthwhile to investigate the feasibility of replacing this architectural element with solar panels to provide not only on-site energy generation, but also a strong aesthetic statement about the energy performance of the building. Further research may indicate that other sustainable efforts such as rainwater collection will also prove to be simple and effective means of energy conservation.

Electrical

Like its mechanical systems, the electrical systems of the Unified Science Center are designed primarily for energy efficiency. Since any redesign of mechanical systems will have an effect on electrical consumption, it is proposed that the electrical load of each mechanical alternative be compared with that of the current design to provide a more complete picture of each redesign's ultimate impact.

It will also be helpful to evaluate the effects on the electrical system of the proposed architecture/sustainability studies. In particular, the use of solar panels will require a close look at their integration with the building electrical system, as well as the possibility of storing the produced electrical energy. Since light sensors are used to adjust artificial lighting levels in many spaces, changes in shading and daylighting methods may have a significant effect on the building's overall electrical energy use.

PROJECT METHODS

In order to provide an accurate analysis of the design and proposed redesigns of the Unified Science Center, it will be necessary to use a variety of software tools. To determine monthly and annual energy use and associated costs and emissions, Trane TRACE will be the primary tool for load calculations. It will also be desirable to perform a simulation in at least one other program, notably eQUEST, to compare results and identify the relative strengths and weaknesses of each program.

To model the building for use in building simulation programs, Autodesk REVIT will act as the workhorse, and AutoCAD may also be used if necessary. To study the effects of solar geometry on the proposed breadth redesigns, the use of Autodesk Ecotect Analysis may be helpful if it is possible to gain enough familiarity with the program to effectively employ it in analysis.

PRELIMINARY RESEARCH

A variety of publications were researched to identify potential alternative designs that are suitable for the Unified Science Center. These include, but are not limited to the following:

ASHRAE Standards, Handbooks, and Journal Archives

Use of ASHRAE materials has been and will be inevitable to study this building's mechanical systems; in addition to Standards 62.1 and 90.1, ASHRAE *Fundamentals* and other publications are tremendously useful. The online ASHRAE Journal archive has proved invaluable for quickly finding relevant information regarding building mechanical systems. In addition to the articles explicitly referenced in this paper, many other texts continue to be extremely helpful.

<http://doas.psu.edu>

Dr. Mumma's compendium of research into dedicated outdoor air systems is especially relevant to the Unified Science Center, and I look forward to delving further into the sea of information contained on his website.

LEED 2009 for New Construction and Major Renovations

Since the Unified Science Center is aiming for LEED Silver certification, it will be necessary to reference this USGBC publication extensively to identify current and potential LEED credits to help meet that goal.

PROPOSED WORK SCHEDULE

The primary goal of the spring semester is to stay ahead of schedule in order to produce a substantive analysis of the proposed mechanical systems redesigns and breadth topic studies and to create effective, quality-driven presentations of this work. It will be critical to invest time during the winter break to get a head start so that work will flow more smoothly upon return to classes. Figure 6 shows the proposed schedule of work to complete the analysis in the time allotted.

Task Name	Duration	Start	Finish
WINTER BREAK	16 days	Mon 12/20/10	Mon 1/10/11
Research depth and breadth topics	30 days	Mon 12/20/10	Fri 1/28/11
Reconstruct TRACE Model	9 days	Sat 1/1/11	Wed 1/12/11
Learn eQUEST	5 days	Mon 1/3/11	Fri 1/7/11
Build eQUEST model	5 days	Mon 1/10/11	Fri 1/14/11
Analyze software results	6 days	Mon 1/17/11	Mon 1/24/11
Perform redesign - HRW	9 days	Tue 1/25/11	Fri 2/4/11
Perform redesign - Chilled Beams	9 days	Tue 2/1/11	Fri 2/11/11
Perform redesign - VAV	5 days	Mon 2/14/11	Fri 2/18/11
Analyze redesigns and compare	5 days	Mon 2/21/11	Fri 2/25/11
Begin breadth work	5 days	Mon 2/28/11	Fri 3/4/11
SPRING BREAK - Relax/Catch up	5 days	Mon 3/7/11	Fri 3/11/11
Finish breadth work	5 days	Mon 3/14/11	Fri 3/18/11
Complete final presentation	9 days	Mon 3/21/11	Thu 3/31/11
Final presentations	5 days	Mon 4/11/11	Fri 4/15/11

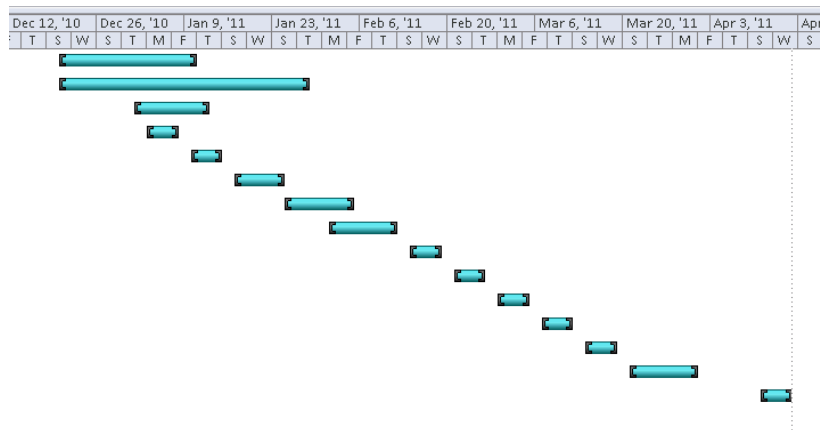

Fig. 6