

HEIFER INTERNATIONAL CENTER

LITTLE ROCK, ARKANSAS

THESIS PROPOSAL

Sikandar Porter-Gill | Structural Option

Advisor: Dr. Thomas Boothby

December 13, 2013



TABLE OF CONTENTS

Executive Summary	3
Purpose	4
Introduction	4
General Structural Information.....	6
Foundation System	6
Gravity Systems.....	7
Lateral System	10
Joint Details.....	12
Documents Referenced.....	15
Materials	16
Determination of Design Loads	17
Problem Statement	19
Proposed Solution	20
Breadth Topic 1 – Mechanical	21
Breadth Topic 2 – Architectural	21
MAE Coursework Requirement	22
Schreyer Honors College Requirements.....	22
Tasks	23
Schedule	25
Conclusion	26

EXECUTIVE SUMMARY

Heifer International Center is located in Little Rock, Arkansas, and functions as the primary headquarters for Heifer International. The non-profit's goal is to reduce world hunger and help communities in need. This amazing, semi-circular glass clad building is four stories high and 490 feet by 62 feet wide, with a 98,000 gross square footage. It overlooks downtown Little Rock and the Arkansas River. The semi-circular shape of the building stems from the "ripple effect" produced from a community helped by the charity's donation of livestock.

Heifer International Center is one of the few Platinum Certified LEED Buildings in the Southern United States. The building is oriented in the east-west direction, to maximize natural lighting. An inverted roof is used to divert rainwater to a five story tower, capable of storing 20,000 gallons of water.

The office building was designed as a composite concrete-steel floor system; with additional reinforcement in the concrete slab to mitigate cracking that occurs over the steel girders. The nature-green painted steel members with wood accented ceilings and flooring give a comfortable and homey environment.

The architect wishes to explore a different structural material, for aesthetic purposes, due to the fact that the existing system is exposed. The new hybrid system of glulam and steel will cause a reclassification of the building as Type IV, per the International Building Code 2009 §602.4, and will prevent the use of the current Underfloor Air Distribution System. This obstacle will lead to a new overhead VAV system, load and ventilation requirements, and a sizing of the supply and return ducts.

Furthermore, an architectural study will be performed on the new exposed structural system. It will compare the designed system to the architectural intent of the Visitor and Education Center, which is next door to the Heifer International Center. The use of glulam in the design provides a unique opportunity to investigate a queen truss, which leads to an integration between the mechanical and structural disciplines. Mechanical and electrical equipment can be incorporated into and hung from the queen truss.

PURPOSE

This report proposes a situation that may have occurred during the design phase of the Heifer International Center. A new design will be required due to a change in the architectural intention that the architect wishes to portray. A method of tasks and a schedule has been developed in order to better understand the existing and new designs. The new design involves using glulam beams and changing the floor system of the office building to one of five potential systems: a plain concrete slab, tongue and groove wood plank, composite wood and concrete, steel decking and concrete, or a post tensioned slab system.

INTRODUCTION

Heifer International’s headquarters mirrors Heifer’s goal of reaching out to a community in need. Heifer International wished their headquarters to match what they were teaching to the world. The shape of the building and campus were inspired by Heifer International’s founder Dan West who expressed, “In all my travels around the world, the important decisions were made where people sat in a circle, facing each other as equals.” This was extended to show the ripple effect Heifer has on needy communities, through their donation of livestock. These communities agree to pass on the offspring of the animal to others—thus creating a ripple effect throughout the community.



Figure 1 | Exterior view of Heifer International Center

Heifer International Center is a four story office building, standing 65 feet tall, with 98,000 square feet. It was constructed between February 2004 and January 2006, at a cost of approximately \$18 million. The design team from Polk Stanley Wilcox Architects and Cromwell Architects Engineers, Inc. were faced with the large challenge of providing an open office plan, in a semi-circular shape, while concurrently offering educational and visual interactions, and sustainable features that would express Heifer International’s mission of ending world hunger and poverty. This was certainly a challenge for the design team—expressing the abstract meanings of the charity, through the physical form of the building.

Heifer International Center continues Heifer’s mission of teaching—the public is allowed access to the facility through tours provided by Heifer personnel, showcasing the sustainable features of the office building. This form of interaction with the building not only educates the community about sustainability, but attracts volunteers and workers to Heifer International—aiding in their desire to help needy communities.

The building has an open floor plan that allows natural light to penetrate to the center of each level, provides views of the river and cityscape, and offers extensive community exchange points with easy access to exterior balconies on each level.

A unique feature of the building includes the use of a custom tree-column design that is used to support the inverted roof at both exterior and interior points. A tree column allows the inverted roof to cantilever over the fourth floor office. The roof is inverted for two reasons. The first is to direct rainwater toward the large silo-tower for storage and greywater use. The second is to provide the ideal angle for a possible future solar panel array.



Photo Credit: Timothy Hursley

Figure 2 | Interior view of Heifer International Center

Heifer International Center was placed in an industrial section of Little Rock that is currently being revitalized. This led to many advantages that the design team used to the building and site's benefit. The site that Heifer International Center occupies was contaminated with industrial waste, and through land reclamation, the soil was removed from the site and taken to a facility to be treated and used elsewhere in the Arkansas region. The site offered more than just the ability to help to reclaim natural land—many bricks and other materials were found during the cleanup process. Most of these reclaimed materials were incorporated into the landscape, and a few were crushed down

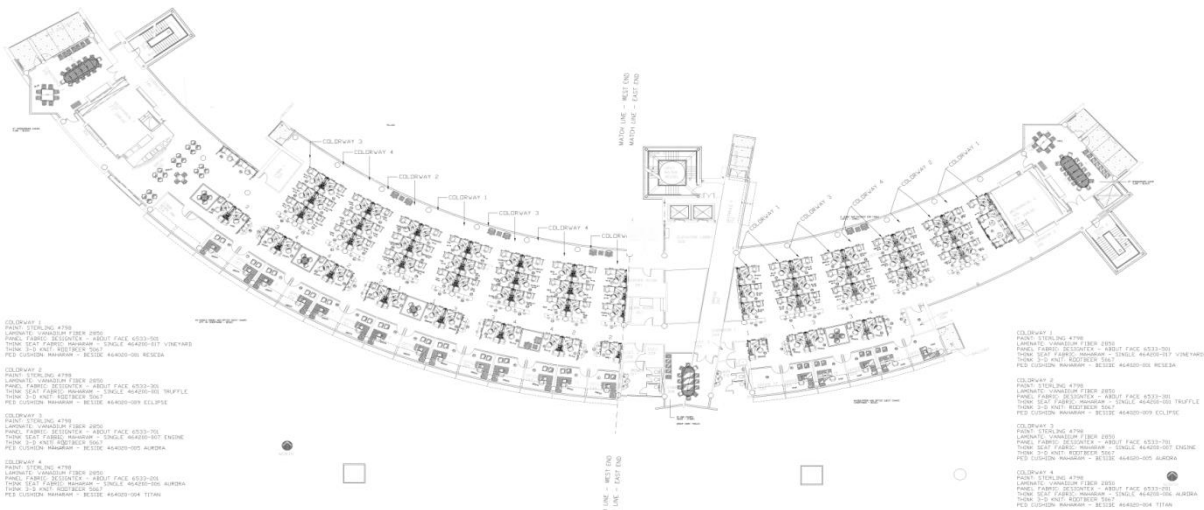

Figure 3 | Typical Floor Plan (HIC CD Furniture Plan)

and used in the footings for the building. The industrial section of the city also housed the steel mill that manufactured Heifer International's steel structure—AFCO Steel Inc. is located only a few blocks away from Heifer's site. Moreover, the mostly glass-clad building is built using Ace Glass Co Inc. as the fabricator of the glass, located less than 100 yards from the building.

EXISTING STRUCTURAL INFORMATION

Heifer International Center is a four story steel structure that is laterally supported by steel plate shear walls. The floor system is a composite decking system, which is supported with large HSS pipes for the framing system. The framing system bears onto a system of piers and footings. Grade beams also bear onto the system of piers and footings but instead support the slab-on-grade. A section of the Ground Level is recessed into the ground 2'-0" to accommodate a larger mechanical room.

FOUNDATION SYSTEM

Geotechnical Report

Grubbs, Hoskyn, Barton & Wyatt, Inc. performed a geotechnical survey of the site in January of 2003. The survey encountered expansive clays on the east side of the building and soft and compressible soils on the west side of the building. Expansive clays expand when they gain water, and contract when they lose water—potentially heaving, or raising, the site elevation 4" to 8". On the east side, the report recommended that the weak soils should be undercut during site grading—approximately 4'-0" to 6'-0". Undercutting involves removing the soil to the specified depth and replacing it with engineered soil, which is compacted. The soil removed would be replaced with low-plasticity clayey sand, sandy clay or gravelly clay. The geotechnical engineer stated that undercutting would allow the use of a slab-on-grade system; however, the use of two potential systems to increase the bearing capacity of the soil would have to be implemented.

The geotechnical engineer recommended either Rammed Aggregate Piers or Drilled Piers, for the foundation system. A Rammed Aggregate Pier[®] (RAP) System by Geopier Foundation Company, Inc., is used to mechanically improve the soil conditions of the site. The RAP system uses "vertical ramming energy" to add layers of crushed aggregate to the site. Generally, Geopiers[™] are formed by drilling 30-inch diameter holes and ramming aggregate into the hole, until a "very stiff, high-density aggregate pier[s]" are formed. This crushed aggregate increased the soil's capacity to between 5 to 7 ksf for the Heifer International Center. Additional Geopiers[™] were provided per structural drawings, due to larger loads or the higher potential for uplift at certain sections of the building. The geotechnical engineer stated, "Total settlement of shallow footings on Geopier[™] elements would be expected to be less than about 1.0 inch and differential settlement less than about 0.5 inch."

Each floor of the Heifer International Center has a similar layout to that shown in the half-plan in [Figure 4](#) above.

A typical bay is 20'-0" x 30'-0", where the floor is supported by a system of beams and girders. The beams and girders collect the loads of the 3VLI 20 gauge composite deck with 2 1/2" of normal weight concrete topping for a total thickness of 5 1/2". The decking compositely acts with the framing members to take advantage of concrete in compression and steel in tension. A detail showing the composite deck configuration with a wide-flange is shown in [Figure 5](#). In addition, at the edges of the building (or the interior sections that are open to below) the composite deck is ended with a bent edge plate.

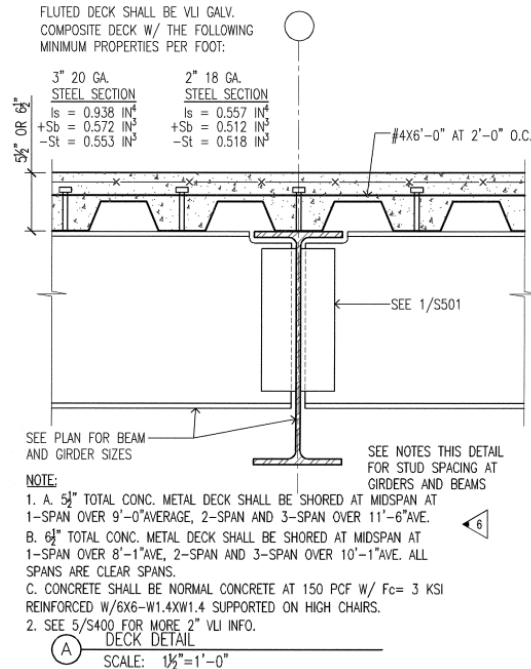

Figure 5 | Interior composite decking detail (Drawing 1A/S500)

It should be noted that all of the floor slabs, although they are supported by the composite decking, are also reinforced with #4 at 6" O.C. in order to control cracks that occur naturally over the girders. This cracking occurs when the slab tries to take tension to make the beam continuous over the girder. A reason for the insertion of this reinforcement is to reduce the magnitude of the deflection occurring at each level due to the use of under-floor air distribution plenums for the mechanical system.

Framing System

The framing system consists of large round HSS shapes, which continue from the ground level to the fourth floor. Originally concrete columns were considered; however, the contractor and steel fabricator were particularly concerned about tolerances maintaining tolerances on concrete columns, and the attendant difficulty of connecting to the beams. Due to these concerns, the design was changed to round steel, HSSs, which vary from 10" to 24". A photograph of the HSS during the erection process is shown in [Figure 6](#).

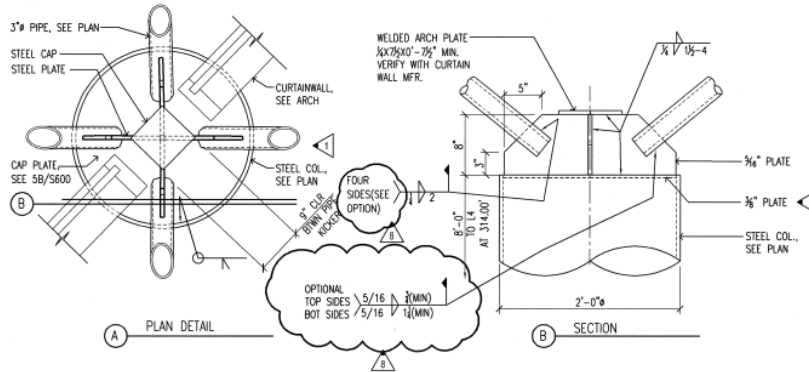

Figure 6 | Photograph during erection of HSS framing

Roof System

The roof-framing plan varies from the floor framing plans—due to the tree-column designs that flare out on the fourth level and attach to the roof girders.

These girders support steel beams, which in turn support a timber wood roof deck. The roof cantilevers approximately 8'-0" beyond the edge of the building, while simultaneously inverting the roof to form a valley. A Thermoplastic Membrane topped with a 4" Glued laminated wood decking makes up the first two layers of the roof, [Figure 7](#). The wood decking has a tongue-and-groove, and is connected to 3" of continuous wood lumber using 8d nails at 6" O.C. This system is bolted to the top flange of the roof steel members. The flare connection detail is shown below in [Figure 7](#), which supports the roof system shown in the section detail of [Figure 8](#).



5 TYPICAL FLARE-OUT PIPE SUPPORT DETAIL
1/2" = 1'-0"

[Figure 7](#) | Roof tree-flare connection detail
(Drawing 5A/S600 and 5B/S600)

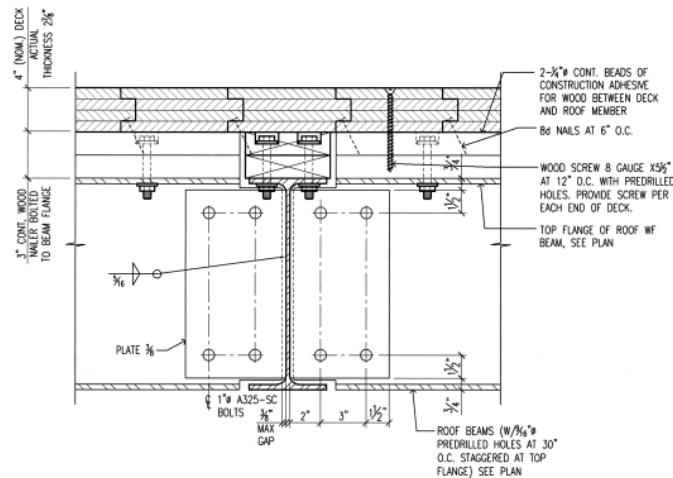

1 TYPICAL WOOD DECK CONNECTION DETAIL
3" = 1'-0"

[Figure 8](#) | Detail of roof framing connection
to timber (Drawing 1/S600)

LATERAL SYSTEM

Heifer International Center is a four story steel structure. It is laterally supported by steel plate shear walls. The floor system is a composite decking system, which is supported with large HSS pipes for the framing system. The framing system bears onto a system of piers and footings. Grade beams also bear onto the system of piers and footings but instead support the slab-on-grade. A section of the Ground Level is recessed into the ground 2'-0" to accommodate a larger mechanical room.

A typical steel plate shear wall (SPSW) is shown in Figure 9, which shows the continuous shear plates that are installed into the wall system. For clarity, the shear plates are shown in red, in both section and plan. These plates are reinforced with C-channels spaced at 24" O.C., welded perpendicular to the shear plates attached to the wall. The C-channels are shown in blue in Figure 9 below. Several shear walls along the ground floor use a composite steel plate shear wall and CMU masonry back wall, which is approximately 6" thick.

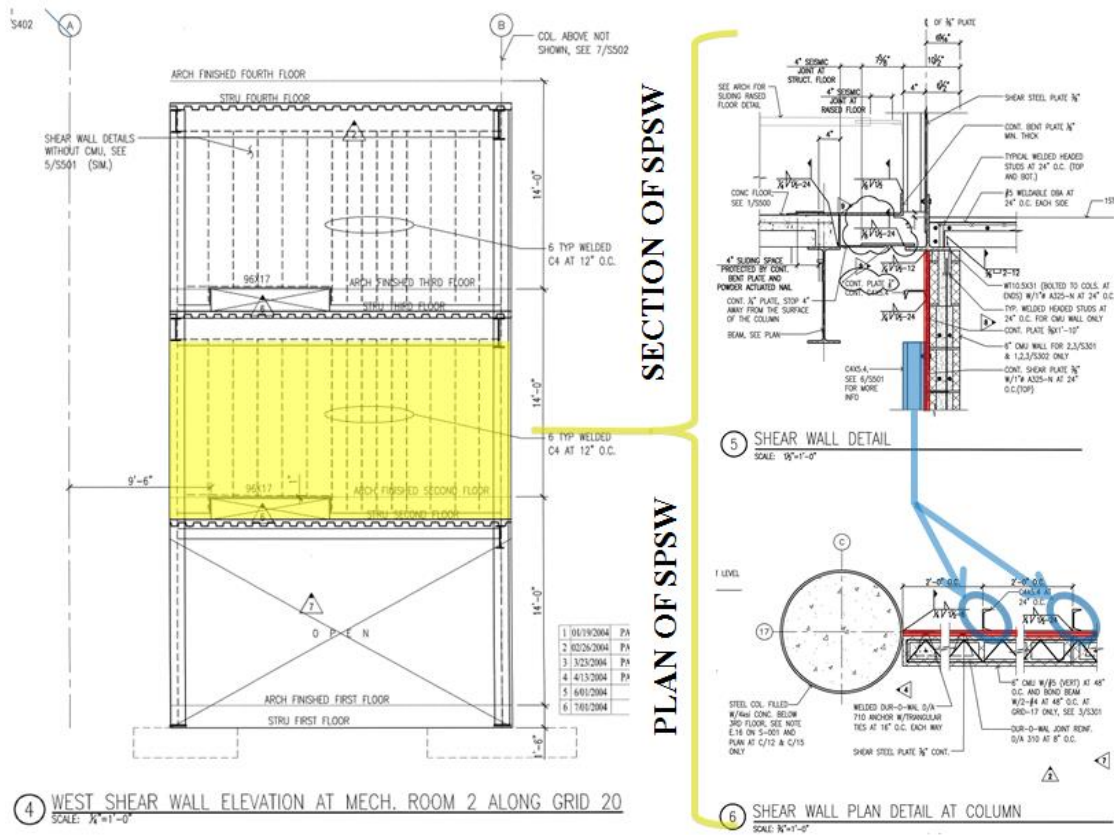

Figure 9 | Typical SPSW elevation, section and plan (Drawing 4/S302, 5/S501 and 6/S501)

Lateral stability is ensured in part by the floor deck, which acts as a diaphragm spanning between SPSWs. SPSWs resist horizontal shear, and effectively act as a vertical girder—the columns act as the flanges and the steel plate acts as the web. The SPSWs span from the foundation to the bottom of the fourth floor. The floor slab is also reinforced with additional #6 at 5” O.C. to assist with diaphragm action of lateral loads during a seismic event. According to the design team, this reinforcement is very important around floor openings—analogueous to reinforcing openings in the flange of a beam.

Lateral loads at the roof are collected by the roof deck diaphragm and then transferred to the round steel columns, passing through the flare out connections of the tree-columns. This lateral load from the columns is transferred to the fourth floor diaphragm, and the lateral load is collected by the SPSWs.

Due to the irregularities of the building’s shape and the 440’-0” length, the semi-circular building was divided into two approximately even sections with a seismic joint. These two halves were analyzed separately for lateral loads, using both static and dynamic methods. Essentially, two separate structures, with separate lateral systems, are joined together to act as one unit. For this technical report, only the east side of the building was analyzed.

This technical report explored the computer modeling of the lateral force resisting system and an analysis of this system.

JOINT DETAILS

Bolted Connections

Most of the connections are shear connections in Heifer International Center, and are bolted in three or four rows. This is shown in [Figure 10](#) below.

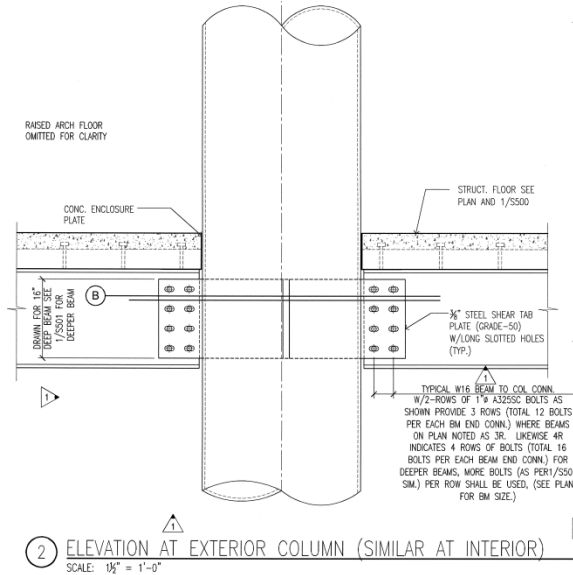

[Figure 10](#) | Typical shear connection
(Drawing 2/S500)

Moment Connections

Small cantilevered balconies are anchored to the building using moment connections, which is shown in [Figure 11](#).

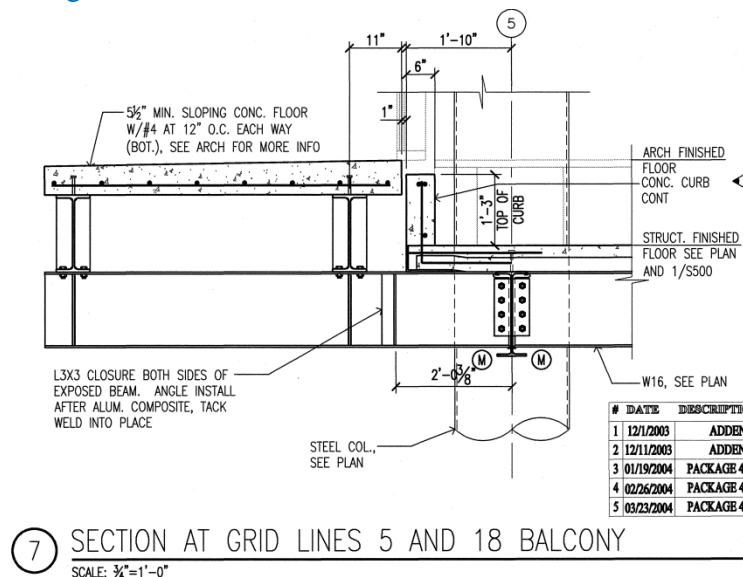

[Figure 11](#) | Typical moment connection supporting balconies located on each level (Drawing 7/S501)

East and West End Balconies

Heifer International Center has large balconies on the east and west that use a shear connection to attach to the building. These balconies are also supported by tension members, HSS pipes. Figure 12 shows a detail section of how the balcony is supported by the shear connection and pipes.

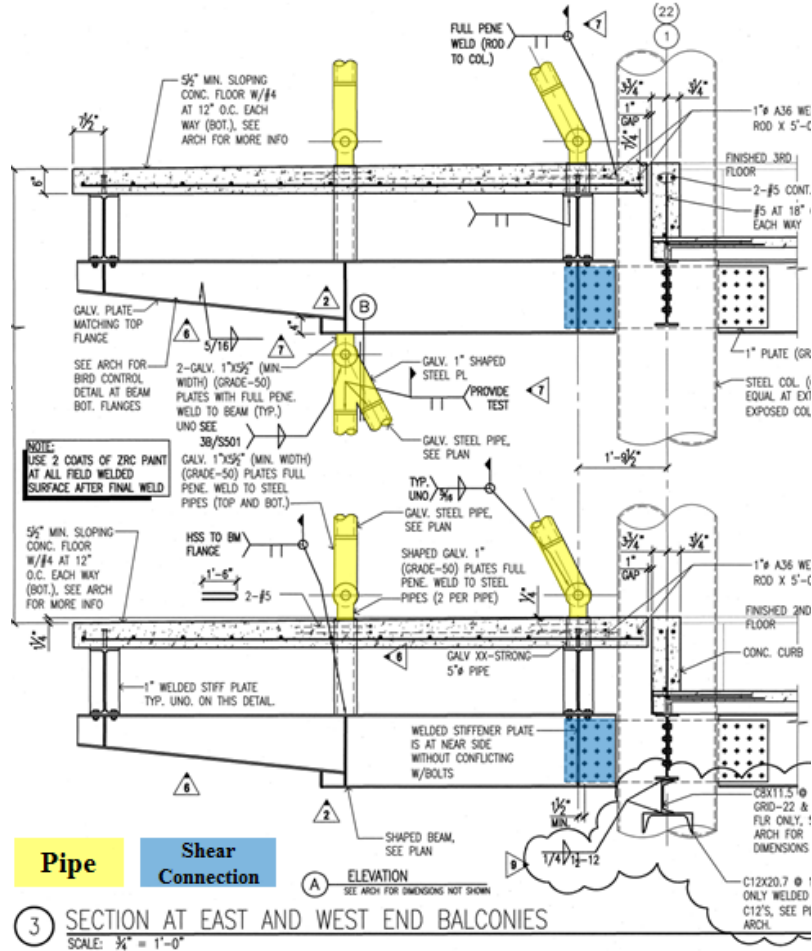
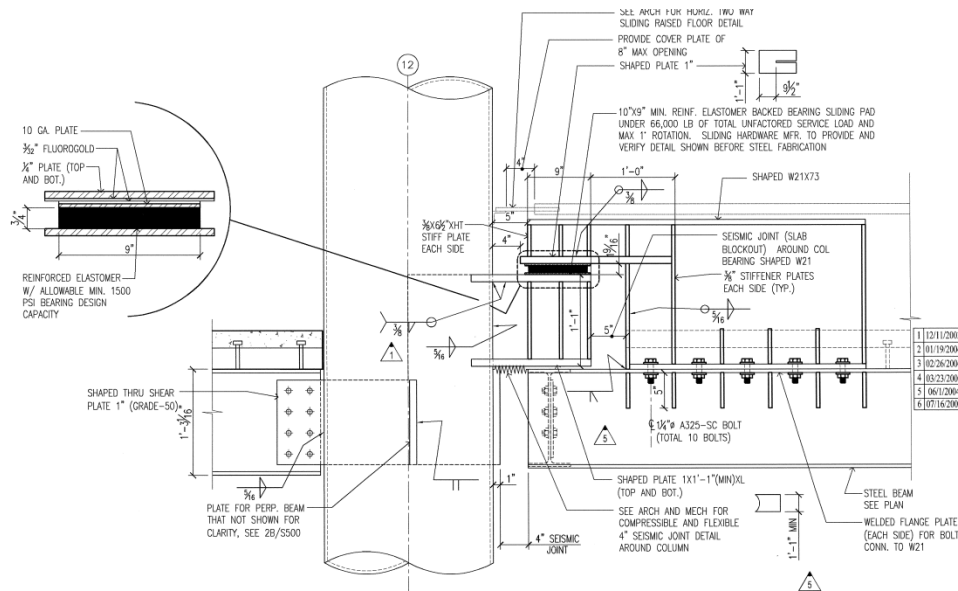

Figure 12 | Typical balcony section showing shear connection and pipes (Drawing 3/S501)

Seismic Joint

Due to Heifer International Center’s semi-circular shape and the extreme length of the building, a seismic joint was installed at each level between the second and fourth stories. A seismic joint is placed between the abutment of the two halves of the building—in order to moderate damage during an earthquake. A seismic joint is similar to an expansion joint; however, it can accommodate movement in both perpendicular and parallel directions. The design for the seismic joint used at each level is shown in [Figure 13](#).



3 COLUMN TO BEAM CONNECTION AT SEISMIC JOINT
SCALE: 1/2" = 1'-0"

Figure 13 | Seismic Joint detail (above) and photograph (below)
(Drawing 3/S500)



DOCUMENTS REFERENCED

The following section lists the codes and design guides used in Heifer International Center, as well as local regulations that supplemented these codes and standards.

International Code Council

International Building Code 2000 (with Little Rock, Arkansas local amendments)
International Building Code 2009

American Society of Civil Engineers

6-1999: Specifications for Masonry Structures
7-1998: Minimum Design Loads for Buildings and Other Structures
7-2010: Minimum Design Loads for Buildings and Other Structures

American Concrete Institute

318-95: Building Code Requirements for Structural Concrete
318-99: Building Code Requirements for Structural Concrete
318-11: Building Code Requirements for Structural Concrete and Commentary

American Institute of Steel Construction

Manual of Steel Construction: LRFD, 2nd Edition
Steel Construction Manual – 14th Edition

American Wood Council

National Design Specification, Design Values for Wood Construction (2012)

American Welding Society

D1.1-98, Structural Welding Code – Steel
D1.3-98, Structural Welding Code – Sheet Steel
D1.4-98, Structural Welding Code – Reinforcing Steel

Arkansas Act 1100 of 1991

Earthquake Structural Requirements for Arkansas

Vulcraft Deck Catalog

Boise Cascade

Boise Glulam Beam Product Guide

Nitterhouse Concrete Products, Inc.

Prestressed Hollow Core Plank Design Data

Reed Construction Data | RS Means

Square Foot Cost 2013
Facilities Maintenance & Repair 2013

University of California, Berkley – Industrial Engineering & Operations Research

American Society of Professional Estimators

MATERIALS

Heifer International Center used the following materials. Their respective stress and strength properties are provided below.

Concrete

	Minimum Strength (ksi)	Air Entraining	Water Reducing Admix Required
Reinforced Footing	3	None	Yes
Reinforced Walls, Grade Beams and Columns	4	5% AIR	Yes
Interior Slab on Grade	3	None	Yes
Typical Floor Slab	3	None	Yes
Walkway	3	5% AIR	Yes
Precast Column, Plank	5	5% AIR	Yes

Steel

Shape	ASTM	Grade	Fy (ksi)
Beams and Girders	A992 or A572	50	50
Hollow Round Columns	A252	3	45
Columns	A992 or A572	50	50
Tube Members	A-500	B	46
Plates	A-36	5% AIR	36
Misc. Steel	A-36	None	36
Connection Bolts	A325-SC	-	-

Other Material

Material	ASTM	Notes
Concrete Masonry Units	C-90	Lightweight, Type I Moisture Controlled $f'_m = 1500$ psi
Mortar	C-270	Type S $f'_m = 1800$ psi
Grout		$f'_c = 2500$ psi
Reinforcing Bars	A-615	Fy = 60

DETERMINATION OF DESIGN LOADS

This piece of the report reviews the loads used in the design of Heifer International Center, and other local Arkansas laws that influenced the design and construction.

NATIONAL CODE FOR LIVE LOAD AND LATERAL LOADS

Live Load	ASCE-7 1998 Chapter 4
Wind Load	ASCE-7 1998 Chapter 6

GRAVITY LOADS

Live Loads

Live loads used in the design of Heifer International Center were referenced using ASCE-7 1998 Chapter 4.

Dead Loads

Dead load allowances were assumed for the typical floor at 95 PSF and roof at 30 PSF. The 95 PSF floor load takes into account the composite decking, potential ponding of concrete, computer technology, mechanical and sprinkler infrastructure.

SNOW LOADS

Ground snow loads for Pulaski County Arkansas are 10 PSF, according to ASCE-7 1998 Chapter 7; however, the timber roof loads increased the design load to 30 PSF due to the high possibility of snow drift into the valley of the roof.

RAIN LOADS

Rain loads were calculated for Heifer International Center using ASCE-7 1998 Chapter 8.

LATERAL LOADS

Wind Loads

Loads due to wind were calculated using ASCE 7 1998 Chapter 6. The design team used an Exposure Category C (§ 6.5.6.1), with a 90mph wind speed.

Seismic Loads

The geotechnical report states that the “...site is located in Seismic Zone 1,” according to the Pulaski County Arkansas State criteria—an “area of low anticipated seismic damage.” The design team referenced ASCE-7 1998 Chapter 9 and the Arkansas Act 1100, Zone 1, of 1991.

LOAD PATHS

Gravity Load Path

The composite deck will carry a load on a floor and transfer it to the beams and girders framing each level. As the floor system collects the load, the load is shifted to the framing system composed of large HSS pipes. This is transferred down to the ground level and is resolved onto piers, footings and grade beams.

The foundation system dissipates this load into the soil that has been engineered using Geopier™ technology.

Roof loads follow a similar path, except the roof diaphragm is composed of wood timber instead of a concrete composite deck. The timber transfers the loads to steel beams and girders, which in turn distribute the loads to tree-column connections. These intricate connections dissipate the energy down to the foundation using the large HSS pipes that compose the framing system.

Lateral Load Path

The façade of the building picks up the distributed load of the wind and transfers this to the floor diaphragm. The steel plate shear wall collects this horizontal force from the diaphragm and generates a vertical force down, towards the foundation system. The foundation system is then allowed to dissipate the base shear generated by the lateral loads.

PROBLEM STATEMENT

The Heifer International Center is currently framed in steel with a composite deck; however, the architect wishes to consider a hybrid system of glulam and steel. Their intention is to see if the architectural features of the Education and Visitor Center, a smaller building next door, may also be applied to the Heifer International Center. In addition, a floor system will need to be researched, compared and selected.



Figure 14 | Heifer International Education and Visitor Center

The previous Technical Reports II and IV analyzed the existing building's gravity and lateral systems, under ASCE 7-1998. Technical Report III analyzed alternative floor systems using ASCE 7-2010. Each phase of the redesign, which will take place next semester, will reference ASCE 7-2010.

The redesign will affect mechanical and architectural characteristics of the Heifer International Center. Their affects will need to be considered in a systems investigation

through the use of two breadths. Due to the use of combustible material, the glulam, as the structural framing, the new classification of the building is Type IV per the International Building Code 2009 §602.4. This classification negates the use of the current Underfloor Air Distribution System and a new overhead VAV system will be used. Exposed structural members will be changed and these new features will need to be considered in the revised glulam design.

The gravity system of Heifer International Center will be redesigned in glulam and the current layout of the lateral system will be kept. However, in order to better understand a wider variety of lateral force resisting systems, a concrete shear wall will be studied. It is important to understand why a steel plate shear wall was selected in the original design and examine whether it was crucial for the design.

PROPOSED SOLUTION

The selection of the glulam redesign for the gravity system leaves five potential floor systems that must be considered.

1. Tongue and groove wood plank
2. Concrete floor system
3. Composite concrete and wood system
4. Steel decking and concrete system
5. Post tensioned slab system

These five floor systems will be researched and the most practical floor system for the Heifer International Center’s glulam beam gravity redesign will be chosen. The glulam beams will be reinforced with tension cables; in a queen post truss design. This advanced modification to a glulam beam may prove beneficial in integration between the structural, mechanical and architectural disciplines. Due to aesthetics and the ease of connection of the glulam beams, the current HSS columns will be kept in the redesign.

Option 1 - Queen Post with Tension Cable

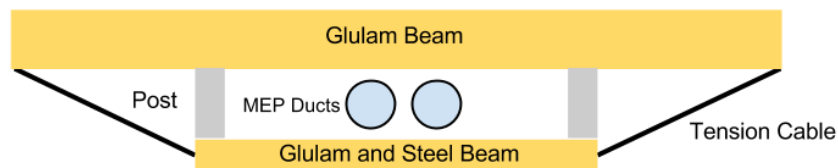

Option 2 - Queen Post with Curved Tension Cable

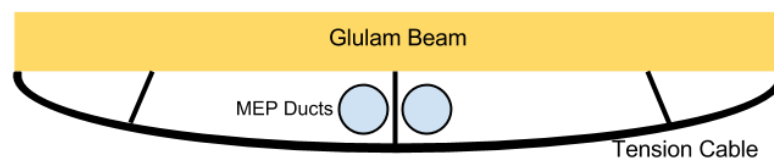

Figure 15 | Potential queen post options

Figure 15 shows two potential designs of the queen post truss, with the incorporation of two beams and tension cables (option 1), or the use of one glulam beam and one tension cable. Each design relies on posts that hold the tension cable, or secondary beam, out and away from the primary beam. This queen post truss increases the strength of the system and can be designed to add a slight camber into the primary beam. The queen post truss will be analyzed using either SAP2000 or ETABS. Preliminary research will be performed as to whether it will be beneficial to use fiber reinforced glulam beams and the type of connection to be used in the hybrid wood and steel building.

The lateral system will be redesigned to incorporate concrete shear walls. This new design will be compared to a steel plate shear wall at the end of the spring semester to determine the utility of the steel plate shear wall used in the current building. As previously analyzed in Technical Report IV, an ETABS model will be developed for the computer modeling aspect of the project.

Due to the use of combustible framing material, the building must be reclassified as Type IV Construction. This new classification will negate the use of the current Underfloor Air Distribution System because the use of concealed spaces is excluded from Type IV Construction of the International Building Code 2009 §602.4. Moreover, exposed structural members will be changed, and these new features will need to be considered in the revised glulam design. These breadth topics are discussed in more detail below.

Moreover, the use of an architectural guideline will aide in the proper development of structural and mechanical systems, in order to respect and expand upon the architectural characteristics of the Visitor and Education Center.

BREADTH TOPIC 1 – MECHANICAL

A glulam beam system will be used in the redesign of Heifer International Center. Due to the updated Construction Type, the Underfloor Air Distribution System will be negated. The mechanical system will have to be changed to a new overhead ductwork system. This new system will need to be hung from the ceiling—and it is important that it is incorporated into the revised structural system so it will visually respect other engineering options. The mechanical system will be able to integrate into the queen post, option 1 or 2, previously discussed in this report.

The mechanical breadth will involve generally sizing the building’s supply and return ducts and ensuring that the ducts are able to fit through the designed queen post. Due to the open office plan of Heifer International Center, careful consideration will need to be taken in the placement of ductwork and its architectural influence. A study will be performed to understand the new structural system’s impact on the thermal envelope, and how this will in turn affect the mechanical system.

BREADTH TOPIC 2 – ARCHITECTURAL

Due to the drastic change in structural building materials an architectural study will be performed to understand how the glulam redesign changes the Heifer International Center. The lateral system redesign should not have an effect on architectural considerations. The Education and Visitor Center next door to the Heifer International Center will be used as a design guide to develop architectural characteristics that should be followed during the duration of the design. This design guide will influence both structural and mechanical disciplines. Revit and AutoCAD will be used to produce renderings of the new architectural features, and the final effect they have on the design.

MAE COURSEWORK REQUIREMENT

The Graduate School of the Pennsylvania State University will be incorporated into the redesign of the Heifer International Center. Graduate level course work will be referenced from AE 530 – Advanced Computer Modeling of Building Structures to develop an advanced CSI ETABS model or a Bentley RAM model of the office building. Additionally, a CSI SAP2000 model may be used to analyze, in detail, the potential queen post that will be used in the redesign. In addition, AE 538 – Earthquake Resistant Design of Buildings will be integrated into the design of the lateral force resisting system.

SCHREYER HONORS COLLEGE REQUIREMENT

This thesis work will be submitted in order to fulfill requirements set by the Schreyer Honors College and the Department of Architectural Engineering. An in depth literature review will be performed of a composite concrete and wood floor system. The intent of this research review will be to gain professional experience as a future Engineering of Record having to specify a floor system not referenced in the International Building Code. The Engineer of Record would have to perform an examination of the proposed system, a composite concrete and wood system, to ensure that it will be safe in the building. This will provide a challenging, in depth examination, of a complex system and reference the work of Dr. Walter G.M. Schneider.

TASKS AND TOOLS

1. Research and compare floor systems
 - a. Research five potential floor systems
 - b. Compare feasibility and cost of each system
 - c. Choose the best floor system
2. Research various computer modeling programs
 - a. Computer modeling program for chosen floor system analysis
 - b. Computer modeling program for queen post analysis
 - c. Computer modeling program for lateral system analysis
3. Breadth Topic 2 – Architectural
 - a. Preliminary Research
 - i. Develop architectural design guidelines
 - ii. Research architectural styles and implications on structural members
 - iii. Begin developing a Revit Architecture Model
4. Design the new hybrid steel and glulam system
 - a. Design gravity system
 - i. Design floor system
 - ii. Design queen posts
 1. Consider implications to story and height requirements
 2. Confirm design in SAP2000 or ETABS
 - iii. Design columns
 1. Upgrade columns to 24” HSS columns
 2. Confirm design in SAP2000 or ETABS
 - iv. Minimize variations from the architecture guidelines
 - b. Design lateral system
 - i. Determine wind and seismic loads based on ASCE 7-2010
 1. Seismic weight of building will change
 - ii. Design concrete shear walls, using existing steel plate shear wall placement
 - iii. Confirm design of shear walls, strength and serviceability, in SAP2000 or ETABS
 - iv. Minimize variations from the architecture guidelines
 - c. Gravity and lateral system write up
5. Breadth Topic 1 – Mechanical
 - a. Generally size supply and return duct sizes
 - b. Investigate impact on thermal envelope
 - c. Analyze any changes to mechanical equipment
 - d. Model ductwork in Revit Architecture Model
 - e. Mechanical breadth write up

6. Breadth Topic 2 – Architectural (continued)
 - a. Continue developing Revit Architecture Model
 - b. Evaluate impact to the interior and exterior architectural elements
 - c. Architectural breadth write up

7. Final Report and Presentation Preparation
 - a. Outline final report
 - b. Prepare and finalize report
 - c. Outline final presentation
 - d. Prepare and finalize presentation
 - e. Practice presentation
 - f. Submit Report and present to jury

CONCLUSION

A scenario has been created, in which the architect is requesting an alternative material for the structure of the Heifer International Center. The architect wishes to explore a different structural material, for aesthetic purposes, due to the fact that the existing system is exposed. A new hybrid system of glulam and steel will be chosen and will provide a unique opportunity to investigate a queen truss. This will lead to integration between the mechanical and structural disciplines. The building will be reclassified as Type IV, per the International Building Code 2009 §602.4, and will prevent the use of the current Underfloor Air Distribution System. This obstacle will lead to a new overhead system, general sizing of ductwork and the careful placement of this ductwork to respect their aesthetic appearance. A study will be performed to understand the new structural system's impact on the thermal envelope, and how this will in turn affect the mechanical system. Mechanical and electrical equipment can be incorporated into and hung from the queen post truss.

The lateral system of the Heifer International Center will be redesigned using concrete shear walls. This new design will be compared to a steel plate shear wall at the end of the spring semester, to determine the utility of the steel plate shear wall used in the current building.

Furthermore, an architectural study will be performed on the new exposed structural system, comparing the designed system to the architectural intent of the Visitor and Education Center, next door to the Heifer International Center.

This project will present a challenging and in depth investigation of a complex structural gravity and floor system, while also expanding the mechanical and architectural breadths. These two breadths will be directly influenced by the designed structural system, and will pose a unique integration between the three disciplines. For this to be evaluated, an architectural model will be created to compare the existing and redesigned office building.

Graduate level course work will be referenced from AE 530 – Advanced Computer Modeling of Building Structures to develop an advanced CSi ETABS model or a Bentley RAM model of the office building. Knowledge gain in AE 538 – Earthquake Resistant Design of Buildings will be integrated into the design of the lateral force resisting system.