

NASA Langley Research Center – Administration Office Building One
Hampton, VA



Project Proposal

Introduction to Proposed Design Alternatives
Revision 1

TABLE OF CONTENTS

Table of Contents

| | |
|-----------------------------------|----|
| Executive Summary _____ | 1 |
| Building Overview _____ | 2 |
| Mechanical Systems Overview _____ | 4 |
| Depth Options _____ | 6 |
| Breadth Options _____ | 8 |
| Additional Resources _____ | 9 |
| Resources _____ | 11 |
| APPENDIX A _____ | 12 |
| APPENDIX B _____ | 13 |

Executive Summary

This report investigates possible alterations to the design of the NASA Langley Administrative Office Building 1, known as AOB1. Although the design of AOB1 meets all design needs and goals, the purpose of this investigation is to determine if other mechanical systems or building components could have reduced the off-site energy consumption of the building and overall life-cycle emissions.

The building enclosure consists mainly of a glass curtainwall system, creating a façade that is almost 50% vertical fenestration. The roof of the atrium is accented by a skylight, which utilizes photovoltaic glass panels. Horizontal overhangs are used on the south and west facades over the main window strips, with another strip of windows above for daylighting purposes. Vertical overhangs were utilized on the east façade.

The main air-side mechanical system of AOB1 is an under floor air distribution (UFAD) system, with floor supply and ceiling return. This system supplies all open office spaces from air handling units (AHU) located on each floor. There is a dedicated outdoor air system (DOAS) located in the building penthouse, which supplies ventilation air to most of the air handling units. This unit is equipped with a heat recovery wheel. The AHU's utilize hydronic heating and cooling coils. All heating and cooling requirements are met by a geothermal transfer field located adjacent to the building.

Multiple options were considered for study, including various mechanical system changes and building envelope alterations. For educational purposes, the depth study chosen is an analysis of different window systems, including triple low-E glazing and photovoltaic glass. This analysis will look into the effects these glass types have on load and energy consumption, and the effect on the existing mechanical system. Three alternatives will be studied: triple low-E on all building facades; PV on south façade under the overhang and triple low-E on all others; and PV on south façade, under the overhang, only. Additionally, a lighting breadth will determine the change in daylighting levels along the south façade from the alternative glass type and adjustments to the lighting plan, electrical circuits and wires will be created, and an environmental breadth into the life-cycle energy and emissions of photovoltaic glass will be studied.

Various books, journals and computer programs, such as COMFEN, TRACE 700, AGi32, and IES Virtual Environment will be referenced throughout the 14 week investigation. A work plan has been created with milestone dates and tasks to ensure consistent progress and appropriate time for final presentation preparation.

Building Overview

NASA LANGLEY

The NASA Langley Research Center was founded in 1917 as the first civil aeronautical research laboratory, and currently has approximately 110 buildings that were constructed over 50 years ago. NASA decided to implement a five-phase revitalization program, which would replace existing buildings with newer, more efficient ones. Their goals for these new buildings were sustainability/efficiency, functionality of the interior environment, pedestrian friendly, and curb appeal. The revitalization program is known as the New Town program, and the first phase consisted of the construction of AOB1.

NEW TOWN PHASE 1

AOB1 is the new headquarters building for NASA's Langley Research Center. The project broke ground in July of 2009 and occupancy began in May 2011. The three story building is approximately 79,000 square feet, with a mechanical penthouse. The building was designed to give viewers a perception of flight. The image below, a rendering from the bridging drawings created by AECOM, demonstrates this original concept, with the glass curtainwall and metal paneling façade and parallelogram footprint with the overhanging upper floors.



Figure 1 – South façade rendering from AECOM Bridging Drawings

The exterior form matches the interior function, with the vertical form towards the center of the building indicating the location of the elevators and lobby. This vertical section also helps to separate the first floor into two sections: employee offices, with an almost 50% glass façade providing adequate daylighting matching the rest of the building, and large conference rooms for

hosting events with its stone façade and windows that are more practical for visual presentations (1)(2).

ENVIRONMENTAL FEATURES

Having achieved a USGBC LEED Platinum rating in v2.2, sustainability and energy efficiency were important in the building design. Horizontal overhangs were utilized on the south and west facades, above the main strip of windows but below a smaller strip, designed for daylighting purposes. The east façade contains vertical sun shades located approximately ten feet apart. The interior design and building shape helps maximize daylighting use, with open office spaces no deeper than three cubicles, and glazed partitions on interior private offices. The building also contains a green roof, a photovoltaic glass skylight, and 30% water reduction plumbing fixtures.

NASA LANGLEY ADMINISTRATIVE OFFICE BUILDING 1

Mechanical Systems Overview

The air distribution system in AOB1 consists of five air handling units and one dedicated outdoor air unit with a heat recovery wheel. The primary air distribution system in the building is an under floor air distribution system (UFAD). The system serves all office spaces and teaming areas on all three floors. Each floor has an air handling unit (AHU-1, 2, 3) located on that floor which ducts into an open floor plenum that distributes to diffusers for the interior spaces and fan powered boxes (FPB) at the perimeter. There is ceiling return, where air is either recirculated to the air handling unit or relieved to the roof, where it goes through the enthalpy wheel at the dedicated outdoor air handling unit (DOAS) that provides pre-conditioned outdoor air for the building. This unit contains heating, cooling and reheat coils, and is set-up for dehumidification. An air riser diagram is shown in Figure 2. This riser diagram can also be found in APPENDIX B.

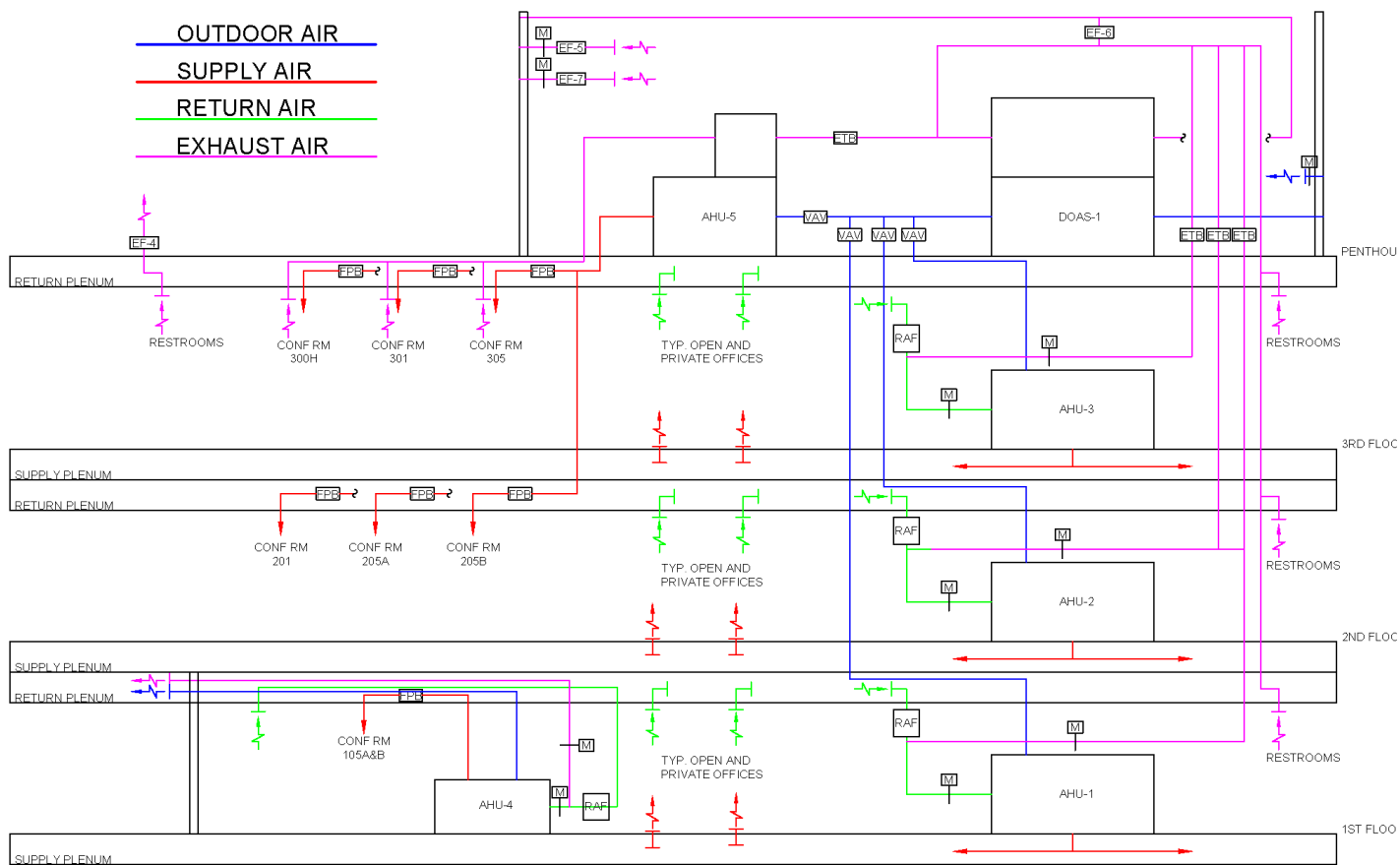

Figure 2 - Air Riser Diagram

NASA LANGLEY ADMINISTRATIVE OFFICE BUILDING 1

There are four VAV's located in the penthouse that control the amount of OA distributed to each respective AHU. Figure 3 shows the mechanical system breakdown of the second floor.

- AHU-5 serves the large conference rooms (such as those in pink in Figure 3) of the upper floors separate of the UFAD system and is located in the penthouse.
- AHU-4 is located on the first floor and serves the large conference rooms on the first floor. It has its own OA louver and is not supplied by the DOAS unit.
- Blower coil units (BCU) serve the atrium and lobby spaces
- Fan coil units (FCU) are used for the IT room on each floor

All areas in white are not directly supplied, which include spaces such as stairwells, elevators, restrooms, kitchenettes, mechanical rooms and electrical rooms.

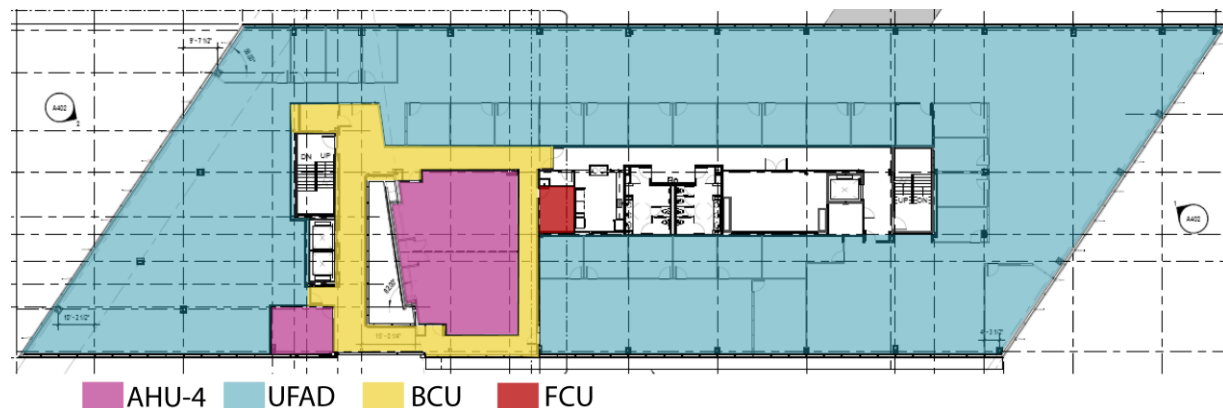

Figure 3 - Second Floor Mechanical System Overview

A geothermal transfer field handles the entire heating and cooling load of the building, with 90 boreholes that are six inches in diameter and 500 feet deep. The well field is connected to six water to water heat pumps (WWHP) with scroll compressors and two sets of three-way control valves that allow the heat pumps to switch between cooling and heating operating, located in the penthouse. The WWHP's have an EER of fourteen and a heating COP of 3.25. Two geothermal water loop circulation pumps with variable frequency drives control the geothermal water loop.

Depth Options

The existing building design meets all the needs of AOB1. However, alternative systems and components could be examined to determine if a more efficient design may have been viable. Options considered for an in-depth analysis include mechanical system design changes and envelope alterations. Options considered include the following:

- **Variable refrigerant flow (VRF):** This alternative, which would be used in the areas served by the UFAD system, would possibly allow a shorter floor-to-floor height by reducing the size of the ductwork required, as only ventilation air would need to be circulated in those spaces. It may also remove the need for the air handling units on each floor that supply the under floor air distribution system.
- **Chilled beams:** This alternative may provide improvements in occupant comfort in the areas supplied by the UFAD system, as well as reduce energy usage in the summer months by allowing the air to naturally mix through the space.
- **Mixed-mode air system:** A mixed-mode air system might consist of mechanically operable windows that would have a control sequence to open the windows for natural ventilation when outdoor air temperature and humidity are ideal. However, this could compromise the acoustical comfort of the space.
- **Window type alterations:** This alternative would explore the impact different glass types would have on the building envelope load. Two types of glass would be explored: low-E triple glazed glass and photovoltaic glass panels. The photovoltaic glass panels would be considered for the main window sections on the south façade, the area under the horizontal overhangs, shown on the south elevation in blue in Figure 4. Energy generated from the photovoltaics would then be used for the operation of the mechanical system.

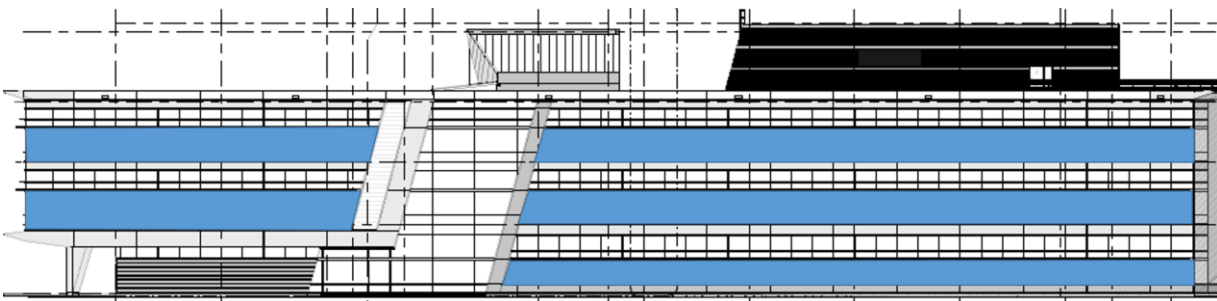

Figure 4 - South Facade: Proposed Photovoltaic Locations

PROPOSED DEPTH

After careful consideration of each option, a decision was made to study the effects of using alternative window types on the building's envelope load, effect on mechanical equipment, and the off-site energy usage to operate the HVAC System, taking into account the energy generated by the on-site photovoltaic system for that window option. This option was chosen for educational purposes, which includes learning about the performance of photovoltaic glass and the impacts different glass types have on the mechanical system.

Three alternative glass placements will be studied for this depth. The first will include changing all windows in the curtainwall to a triple low-E glass type. The second alternative will include the triple low-E glass on the north, east, and west facades, and the windows above the horizontal overhangs on the south façade, and photovoltaic glass under the overhang on the south façade. The final alternative will be the photovoltaic glass on the south façade under the overhangs only. Again, Figure 4 shows the planned locations of the photovoltaic glass panels on the south façade.

Breadth Options

LIGHTING BREADTH

The alternative window types to be explored have different visible light transmittance than the original windows, which will affect the daylighting. Therefore, a lighting calculation must be performed to determine the new level of artificial light that must be provided to the space. A sample lighting plan will be created for the open office space along the south facade that provides the necessary lighting levels, and adjustments to the electrical circuits and wiring will be determined.

ENVIRONMENTAL BREADTH

The second breadth to be explored deals with life-cycle energy and emissions of the photovoltaic windows, including energy required for and emissions during production. This analysis will include a comparison of the energy required to make the windows and the emissions produced with the energy and emissions avoided with their application in the building. The main metric for comparison of emissions will be CO₂ production. The purpose of this analysis is to determine what the full life-cycle costs of the alteration would be.

Additional Resources

PRELIMINARY RESEARCH

A number of sources were used in the preliminary research for this proposal. These sources were helpful for determining the various depth options, and provide valuable information for various aspects of a building that will not necessarily correlate directly to the proposed depth.

1. Krauter, S. (2006). *Solar Electric Power Generation - Photovoltaic Energy Systems: Modeling of optical and thermal performance, electrical yield, energy balance, effect on reduction of greenhouse gas emissions*. Berlin: Springer.
2. Tassou, S. (1998). *Low-Energy Cooling Technologies for Buildings: Challenges and Opportunities for the Environmental Control of Buildings*. Bury St Edmunds: Professional Engineering Publishing.
3. Luling, C. (2009). *Energizing Architecture: Design and Photovoltaics*. Berlin: Jovis.
4. Prasad, D., & Snow, M. (2005). *Designing with Solar Power: A Source Book for Building Integrated Photovoltaics (BiPV)*. Mulgrave, Vic.
5. Kibert, C. (2005). *Sustainable Construction: Green Building Design and Delivery*. Hoboken, N.J.: John Wiley.
6. Heerwagen, D. (2004). *Passive and Active Environmental Controls: Informing the Schematic Designing of Buildings*. New York, N.Y. [etc.: McGraw-Hill.
7. Heating, R. (2006). *ASHRAE GreenGuide: The Design, Construction, and Operation of Sustainable Buildings* (2nd ed.). Atlanta, GA: American Society of Heating, Refrigerating, and Air-conditioning Engineers.
8. Dale, M., & Benson, S. (2013). Energy Balance of the Global Photovoltaic (PV) Industry - Is the PV Industry a Net Electricity Producer? *Environmental Science & Technology*, 130312080757002-130312080757002.

TOOLS AND METHODS

A variety of resources will be used for analysis. Trane TRACE 700 will continue to be used for future load and energy simulations. The same model will be used with alternatives for each glass type, in order to remain consistent for the results comparisons. COMFEN will be used in the early phases of analysis to predict the type of results that should be anticipated from the TRACE 700 calculation, for clarification. Various publications, such as the ASHRAE Handbook and Standards and the resources listed above, will also be referenced. A hand calculation will be done for determining the energy generated by the photovoltaic glass, based on the manufacturer specifications chosen for the analysis. Programs such as AGi32 and IES Virtual Environment will

be utilized for the lighting breadth, and the Greenhouse Gas Equivalencies Calculator provided by the EPA will be used to determine the tons of carbon dioxide emitted.

DRAFT WORK PLAN

A draft work plan has been created for the Spring Semester and can be found in APPENDIX A.

Resources

1. Flynn, J. (2008, January 1). Visualizing the Future of NASA Langley Research Center. Retrieved September 12, 2014, from <http://proceedings.esri.com/library/userconf/feduc08/papers/feduc.pdf>
2. Quinville, T. (2009, September 16). New Town NASA Langley Research Center's Revitalization Initiative Report to Hampton Roads SAME Chapter. Retrieved September 12, 2014, from <http://posts.same.org/hamptonroads/NASANewTownSep2009.pdf>

Renderings from AECOM bridging documents: www.aecom.com

APPENDIX A

Work Schedule

Valerie Miller
Mechanical

Advisor: Dr. Freihaut
Revised: 01/16/2015

Spring Semester Work Schedule

| | JAN 11-17 WEEK 1 | JAN 18-24 WEEK 2 | JAN 25-31 WEEK 3 | FEB 1-7 WEEK 4 | FEB 8-14 WEEK 5 | FEB 15-21 WEEK 6 | FEB 22-28 WEEK 7 | MAR 1-7 WEEK 8 | MAR 15-21 WEEK 9 | MAR 22-28 WEEK 10 | MAR 29-APR 4 WEEK 11 | APR 5-11 WEEK 12 | APR 12-18 WEEK 13 | APR 19-25 WEEK 14 | APR 26-MAY 2 WEEK 15 | | | |
|-------------------------|--|---------------------|---|-------------------|---|---------------------|---------------------|-------------------|---|----------------------|-------------------------|---------------------|---|----------------------|-------------------------|--|--|--|
| GLASS RESEARCH | | | | | | | | | | | FINAL REPORT | | PRESENTATIONS | | | | | |
| COMFEN | | | | | | | | | | | | | | | | | | |
| TRACE 700 | | | | | | | | | | | | | | | | | | |
| PV ELEC PRODUCTION CALC | | | | | | | | | | | | | | | | | | |
| | | | MECHANICAL EQUIP ALTERATIONS | | | | | | COST ANALYSIS | | | | | | | | | |
| | DAYLIGHTING CALCULATIONS | | | | | | | | | | | | | | | | | |
| | | | NEW LIGHTING LAYOUT | | | | | | | | | | | | | | | |
| | | | | | CIRCUIT REVISIONS | | | | | | | | | | | | | |
| | | | PV PRODUCTION ENERGY/EMISSIONS RESEARCH | | | | | | | | | | | | | | | |
| | | | | | | | LIFE-CYCLE PV CALC | | | | | | | | | | | |
| PROPOSAL UPDATES | | | | | | | | | | | | | | | | | | |
| | | | | | FINAL REPORT WRITE-UP WITH PROGRESS | | | | | | | | | | | | | |
| | | | | | | | | | | | PRACTICE | | | | | | | |
| | | | | | | | | | | | | | WRAP-UP | | | | | |
| | MILESTONE 1 - JAN 23 (a) Windows selected for analysis (b) COMFEN done (c) PV electricity output determined (d) Trace 700 started | | | | MILESTONE 2 - FEB 13 (a) Mechanical alterations determined (b) Daylight requirements calculated (c) Lighting layout begun (d) PV research underway | | | | MILESTONE 3 - MAR 6 (a) Lighting breadth complete (b) PV research done (c) Cost analysis underway (d) PV life-cycle calculation underway | | | | MILESTONE 4 - APR 3 (a) Environmental breadth done (b) Cost analysis done (c) Final report done | | | | | |

APPENDIX B

Air Riser Diagram

OUTDOOR AIR
SUPPLY AIR
RETURN AIR
EXHAUST AIR

